

БМ-19131

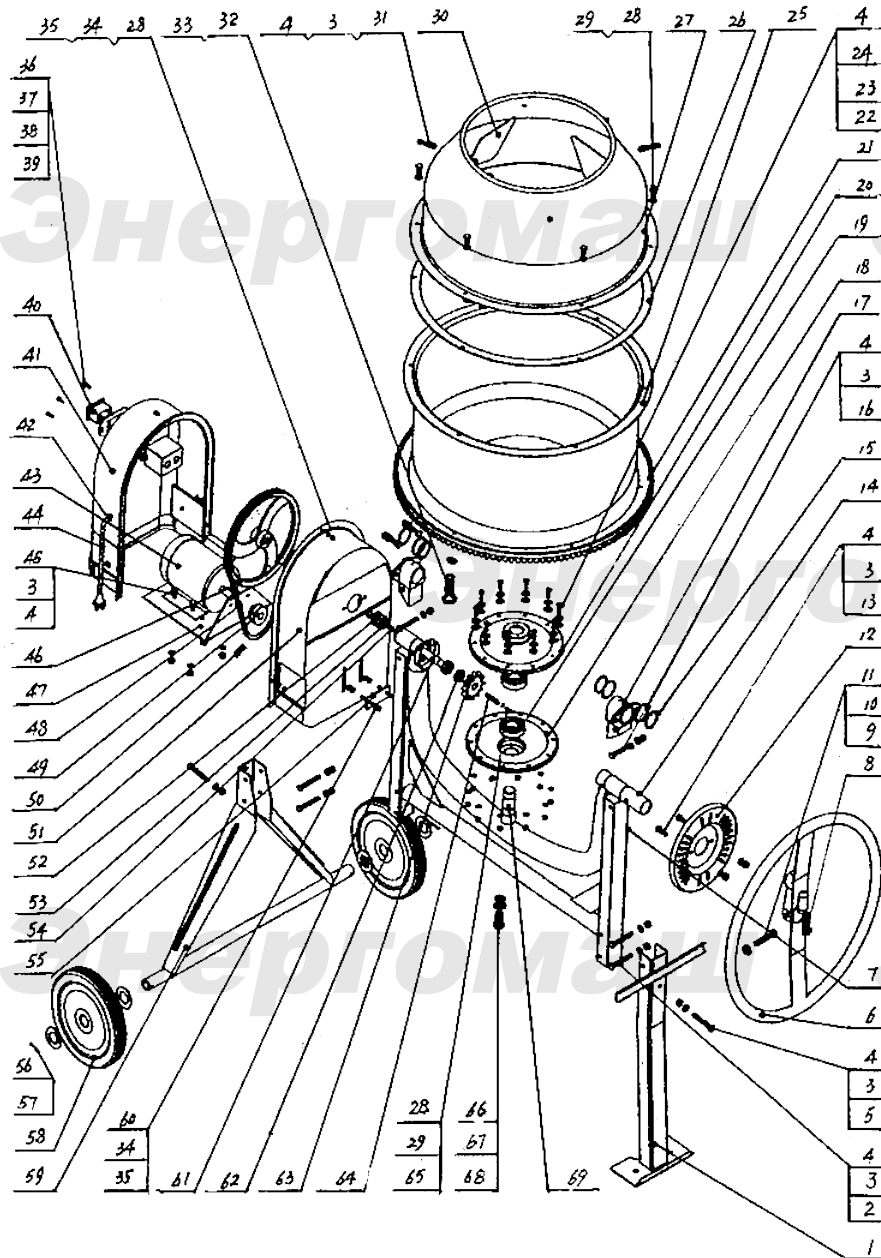

NO.	DESCRIPTION	NO.	DESCRIPTION
1	SUPPORT BRACKET	36	SETSCREW M4*12
2	HEX BOLT M8*65	37	FLAT WASHER 4
3	FLAT WASHER 8	38	ELASTIC WASHER 4
4	HEX NUT M8	39	HEX NUT M4
5	HEX BOLT M8*55	40	SWITCH
6	DEGREE ADJUSTING WHEEL	41	MOTOR BASE COVER(OUTER)
7	STAND	42	CORD SLEEVE
8	COIL SPRING	43	MOTOR
9	HEX BOLT M10*70	44	POWER CORD
10	WASHER 10	45	HEX BOLT M8*16
11	HEX NUT	46	PULLEY(L)
12	DEGREE ADJUSTING PLATE	47	MOTOR BASE PLATE
13	HEX BOLT M8*25	48	V-BELT O-787
14	SUPPORT ARM	49	PULLEY(S)
15	C-CLIP	50	SETSCREW M6*12
16	HEX BOLT M8*60	51	MOTOR BASE COVER(INNER)
17	IRON TUBE FIXTURE(R.H)	52	WASHER
18	WASHER COVER(LOWER)	53	BALL BEARING 60206
19	BALL BEARING	54	FLAT KEY 5*28
20	WASHER COVER(UPPER)	55	CLAMP
21	RING GEAR	56	PIN 5*45
22	HEX BOLT M8*20	57	FLAT WASHER 25
23	WASHER	58	WHEEL
24	ALUMINIUM WASHER	59	HINGE BRACKET
25	DRUM(LOWER)	60	HEX BOLT M6*60
26	RUBBER GASKET	61	SHAFT
27	DRUM(UPPER)	62	FLAT WASHER 14
28	SETSCREW M6*16	63	GEAR
29	ELASTIC WASHER 6	64	FLAT KEY 5*16
30	MIXER	65	WHEEL
31	SETSCREW M8*16	66	HEX BOLT M14*30
32	HEX BOLT M8*12	67	ELASTIC WASHER 14
33	ELASTIC WASHER 8	68	WASHER
34	FLAT WASHER 6	69	SHAFT
35	HEX NUT M6		