

# RH-2517CD-X

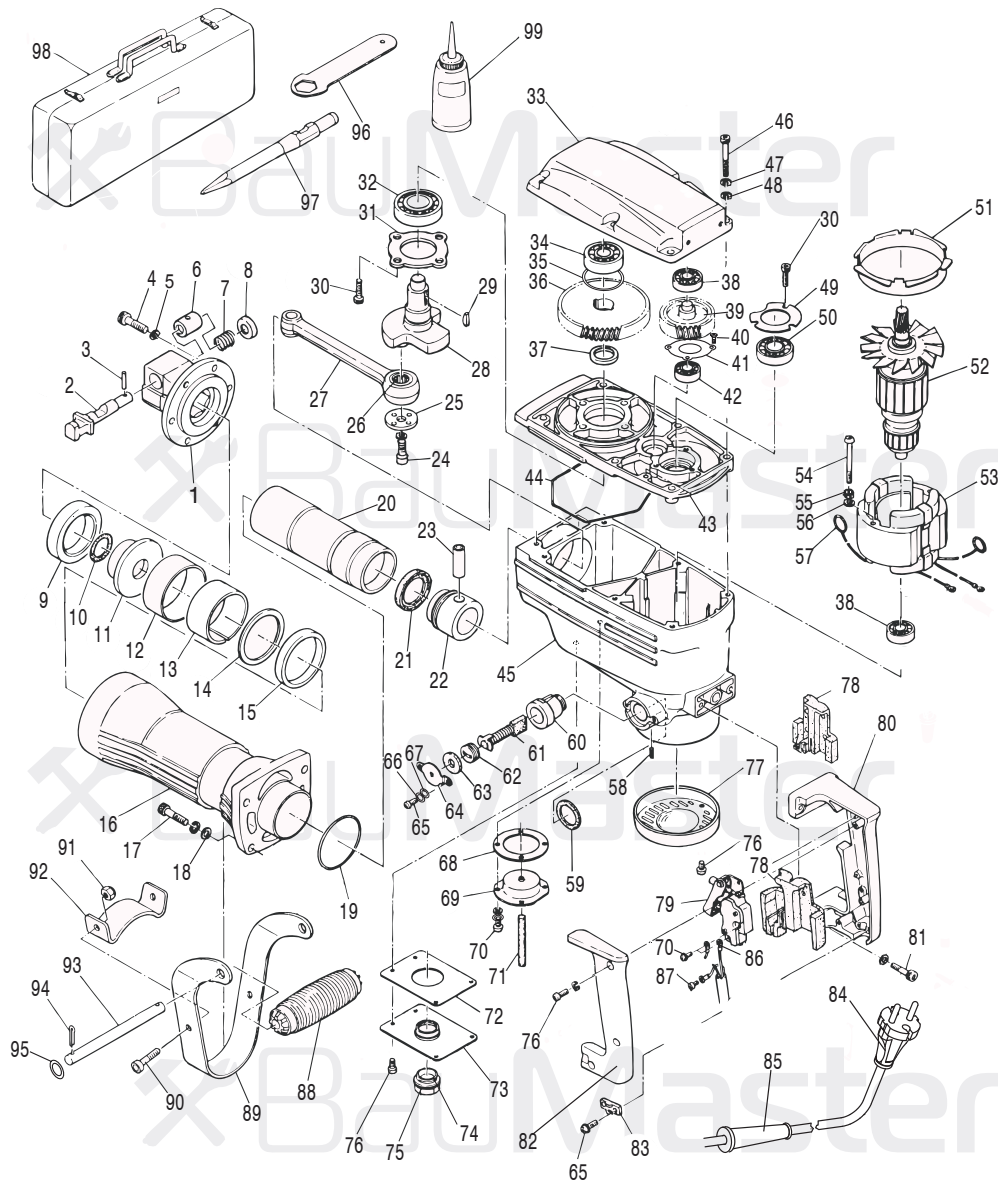

NO.	DESCRIPTION	NO.	DESCRIPTION
1	FRONT COVER	51	FAN GUIDE
2	LEVER	52	ARMATURE ASSY
3	NEEDL ROLLER	53	STATOR ASSY
4	M8*30 HEXAGON SOCKET HD.BOLT	54	M5*60 HD.MACHINE SCREW
5	M8 SPRING LOCK WASHER	55	M5 SPRING LOCK WASHER
6	LOCK BOLT	56	M5 THOOCHED LOCK WASHER
7	LEVER SPRING	57	BRUSH TERMINAL ASSY
8	LEVER WASHER	58	M5*8 SLOTTED SET SCREW
9	DAMPER 48*67.5*14.7	59	RUBBER WASHER
10	O-RING	60	BRUSH HOLDER
11	SHANK SLEEVE	61	CARBON BRUSH
12	MOUTH COVER	62	BRUSH CAP
13	MOUTH	63	CAP RUBBER
14	MOUTH WASHER 57.4*68.4*2	64	CAP COVER
15	URETHANE RING	65	M4*16 HD.MACHINE SCREW
16	CYLINDER HOUSING	66	M4 THOOCHED LOCK WASHER
17	M8*35 HEXAGON SOCKET HD.BOLT	67	M4 SPRING LOCK WASHER
18	WASHER	68	HOLDER SEAL
19	O-RING 60*2	69	FELT HOLDER
20	CYLINDER	70	M4*10 HD.MACHINE SCREW
21	SEALING	71	OIL FELT
22	PISTON	72	COVER SEAL
23	PISTON PIN	73	COVER PLATE
24	M8*25 HEXAGON SOCKET HD.BOLT	74	OIL GAUGE O-RING
25	CRANK WASHER	75	OIL GAUGE
26	NEEDLE BEARING NK18 26 20	76	M5*12 HD. MACHINE SCREW
27	CONNECTING ROD	77	TAIL COVER
28	CRANK SHAFT ASSY	78	SUPPORTING DISC
29	FEATHER KEY 4*6.5*16	79	SINGLE POLE SWITCH
30	M5*20 HEXAGON SOCKET HD.BOLT	80	HANDLE
31	BEARING COVER	81	M6*25 HEXAGON SOCKET HD.BOLT
32	BALL BEARING 6205RZ	82	HANDLE COVER
33	GEAR HOUSING	83	CORD CLIP
34	BALL BEARING 6302RZ	84	CORD ASSY
35	SHAFT RING	85	GROMMET
36	FINAL GEAR	86	CONNECTOR
37	DISTANCE RING	87	CONNECTING WIRE
38	BALL BEARING 6201RZ	88	AUXILIARY HANDLE
39	COUNTER GEAR	89	SIDE HANDLE
40	M5*12 HD. MACHINE SCREW	90	M8*16 HIGH TENSION BOLT
41	BEARING COVER	91	U-NUT M8
42	BALL BEARING 6001RZ	92	HANDLE STAY
43	INNER COVER	93	HANDLE SHAFT
44	SEAL RING	94	SPLIT PIN 3*30
45	HOUSING COVER	95	WASHER
46	M6*45 HEXAGON SOCKET HD.BOLT	96	WRENCH
47	M6 SPRING LOCK WASHER	97	POINT CHISEL
48	M6 THOOCHED LOCK WASHER	98	CASE ASSY
49	BEARING COVER	99	OIL FEEDER
50	BALL BEARING 6203RZ		