

RH2509BZ

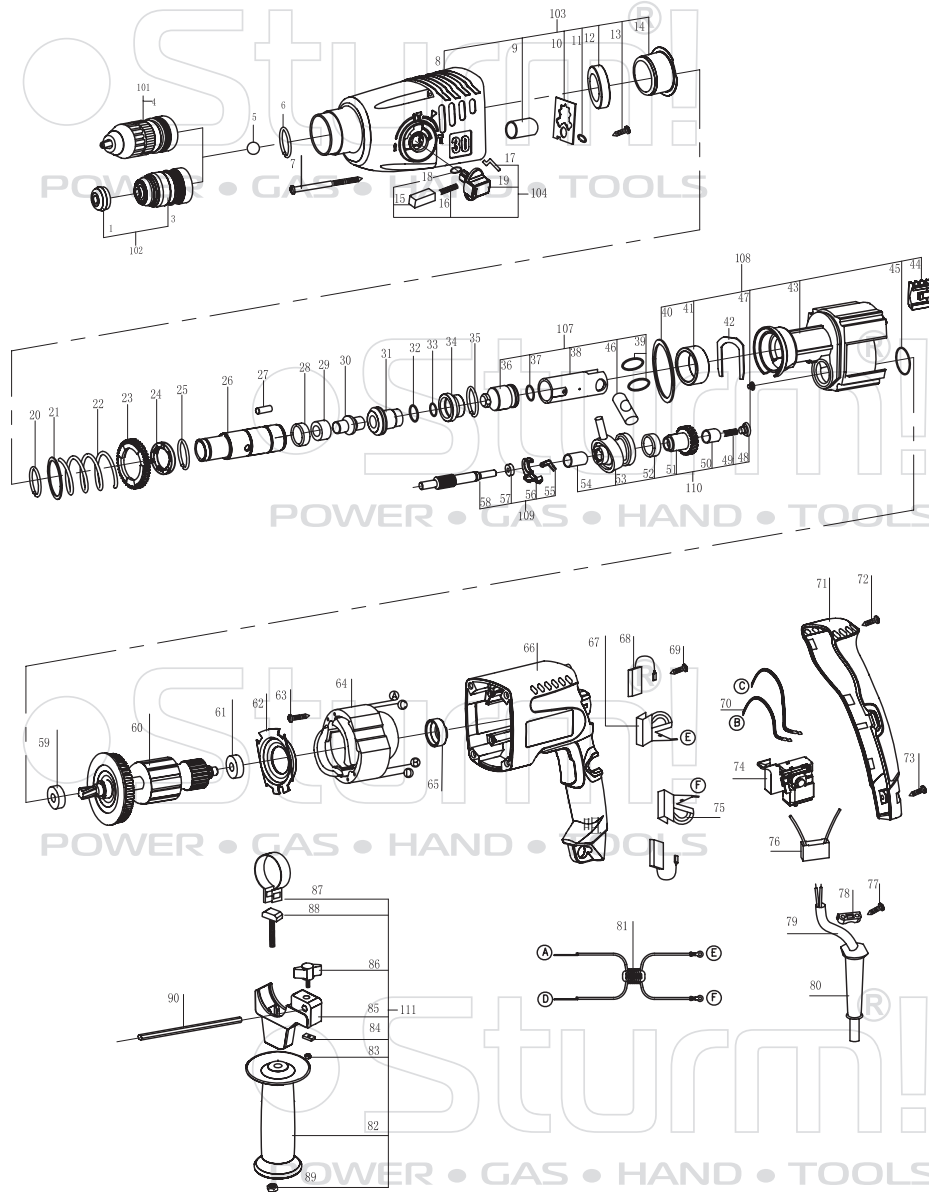

NO.	DESCRIPTION	NO.	DESCRIPTION
1	PROTECTIVE CAP	51	CYLINDRICAL GEAR
3	SDS CHUCK	52	NEEDLE BEARING
4	QUICK-CHANGE KEYLESS CHUCK	53	ROCKER BEARING
5	BALL C7.14	54	NEEDLE SLEEVE
6	RETAINING RING	55	SPRING CLIP
7	SCREW	56	SHIFT FORK
8	GEAR HOUSING	57	BALL BEARING
9	NEEDLE BEARING	58	TOOTHED SHAFT
10	TAB WASHER	59	BALL BEARING
11	PLATE SPRING	60	ARMATURE
12	OIL SEAL	61	BALL BEARING
13	SCREW	62	AIR-DEFLECTOR RING
14	BUSH	63	SCREW
15	SWITCH BUTTON	64	STATOR
16	COMPRESSION SPRING	65	RUBBER BEARING SLEEVE
17	DRIVER PIN	66	MOTOR HOUSING
18	O-RING	67	BRUSH HOLDER
19	SELECTOR KNOB	68	CARBON BRUSH
20	RETAINING RING	69	SCREW
21	SUPPORTING DISC	70	CONNECTING CABLE
22	SPRING	71	HOUSING COVER
23	CYLINDRICAL GEAR	72	SCREW
24	CATCH DISK	73	SCREW
25	SNAP RING	74	SWITCH
26	RATCHET SLEEVE	75	BRUSH SPRING
27	STRAIGHT PIN	76	CAPACITOR
28	SEAL RING	77	SCREW
29	THRUST RING	78	CORD CLAMP
30	IMPACT ROD	79	CORD
31	GUIDE BUSHING	80	CORD GUARD
32	O-RING	81	INDUCTOR
33	O-RING	82	AUXILIARY HANDLE
34	DAMPING BUSHING	83	NUT
35	RETAINING RING	84	SUPPORT BLOC
36	STRIKER	85	CLAMP HOLDER
37	O-RING	86	WINGED SCREW
38	PISTON	87	CLAMPING BAND
39	SHIM RING	88	T-BOLT
40	O-RING	89	NUT
41	BUSHING	90	DEPTH GAUGE
42	HOLDING PLATE	101	KEYLESS CHUCK ASSEMBLY
43	BRACKET	102	SDS CHUCK ASSEMBLY
44	PROTECTIVE PLATE	103	HEAD COVER ASSEMBLY
45	O-RING	104	ADJUSTMENT KNOB ASSEMBLY
46	PISTON PIN	107	CYLINDER ASSEMBLY
47	CONVEX WASHER	108	BRACKET ASSEMBLY
48	BUSHING	109	MIDDLE SHAFT ASSEMBLY
49	COMPRESSION SPRING	110	ROCKER BEARING ASSEMBLY
50	NEEDLE SLEEVE	111	AUXILIARY HANDLE ASSEMBLY