

# RH2528V

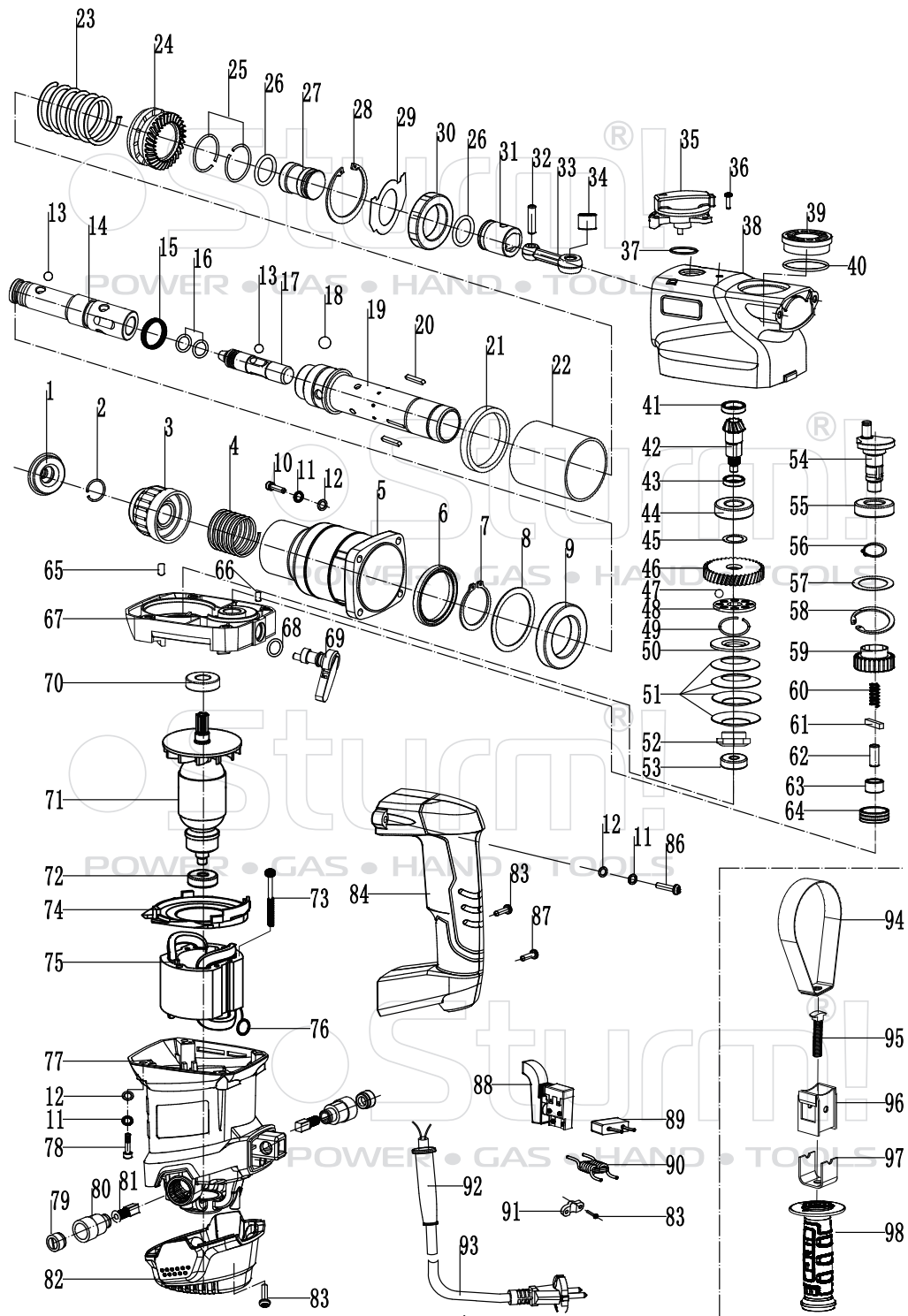

NO.	DESCRIPTION	NO.	DESCRIPTION
1	RUBBER HEAD	50	ACTIVE PLATE
2	STEEL RING 17.5X2	51	DISC SPRING
3	SPIN SLEEVE	52	NUT M10X0.75
4	SPRING 30.2X1.8X76	53	BEARING 627
5	CYLINDER HOUSE	54	CRANK
6	SEAL RING FB35X51X6	55	BEARING 6003
7	RING 35	56	RING 17
8	WASHER 45X54.5X1	57	WASHER 34.5X28.5X1
9	BEARING 61907	58	RING 35
10	SCREW M5*22	59	GEAR
11	SPRING WASHER 5	60	SPRING
12	PLAIN WASHER 5	61	KEY 5X5X22
13	STEEL BALL 7.14	62	PIN 7*19
14	TELEFLEX	63	BUSH 16*12*10
15	OIL SEAL 20.9*22X4	64	STEEL SLEEVE 22X26X9
16	O-RING 11X2	65	PIN5*14
17	IMPACT HAMMER	66	RUBBER PIN 3*10.5
18	STEEL BALL 7.94	67	MIDDLE COVER
19	CYLINDER	68	O-RING 11*1.5
20	FLAT KEY 3X2.5X18	69	KNOB FOR HAMMER
21	PLASTIC SLEEVE	70	BEARING 6001
22	DISTANCE RING	71	ROTOR
23	SPRING 33.5X3.5X76	72	BEARING 608
24	BIG CONE GEAR	73	TAPPING SCREW ST4.8*60
25	STEEL RING 28X1.6	74	FAN GUIDE
26	O-RING 19X3.1	75	STATOR
27	RAMMER 25*30	76	SPRING
28	RING 47	77	HOUSING
29	OIL BAFFLE PLATE	78	SCREW M5X50
30	BUSH 30X47X9	79	BRUSH COVER
31	PISTON	80	BRUH HOLDER
32	PISTON PIN	81	CARBON BRUSH
33	CONNECTING ROD	82	REAR COVER
34	BUSH12*10*8	83	TAPPING SCREW ST3.9*16
35	KNOB	84	HANDLE
36	SCREW M4X14	86	SCREW M5*22
37	O-RING 10.2X1.9	87	SCREW ST3.9*20
38	GEAR BOX	88	SWITCH
39	OIL COVER	89	CAPACITOR
40	O-RING 31.5X2	90	INDUCTANCE
41	SEAL RING FB19X28X4.5	91	CABLE
42	CONE GEAR SHAFT	92	CABLE SHEATH
43	SPACE WASHER 15X19X4.7	93	CABLE BOARD
44	BEARING 6002	94	HOOP
45	WASHER 14.1X19X0.5	95	T-SCREW M8X35
46	BIG GEAR	96	HOLDER
47	STEEL BALL 5	97	BRACKET
48	FIXED PLATE	98	AUXILIARY HANDLE
49	STEEL RING 12.5X1		