

AW97I17L

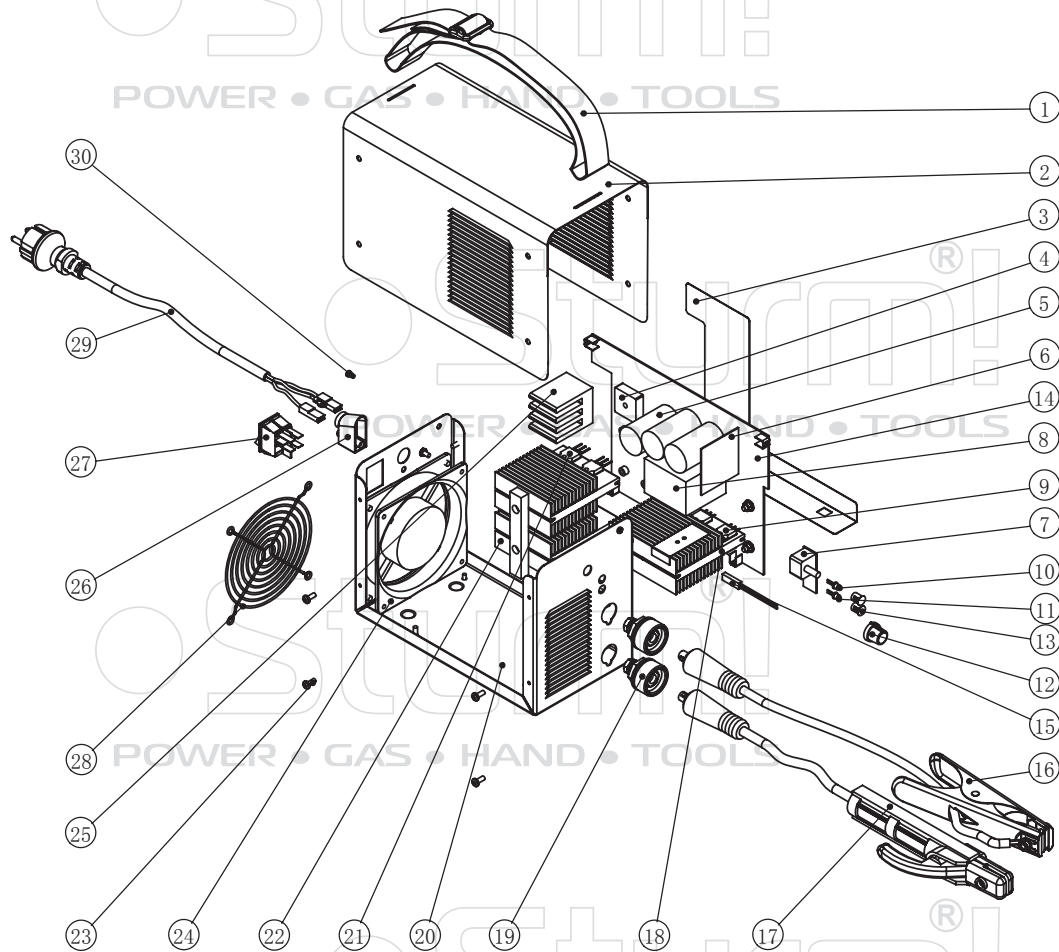

| NO | DESCRIPTION |
|----|--------------------------|
| 1 | BELT |
| 2 | STEEL COVER |
| 3 | INSULTAING CLAPBOARD |
| 4 | BRIDGE |
| 5 | CAPACITOR |
| 6 | CONTROL PCB |
| 7 | POTENTIOMETER |
| 8 | TRANSFORMER |
| 9 | FAST RECOVERY DIODE(FRD) |
| 10 | POWER LED |
| 11 | THERMAL PROTECTION LED |
| 12 | POTENTIOMETER BUTTON |
| 13 | LED COVER |
| 14 | MAIN PCB |
| 15 | TEMPERATURE CONTROLLER |
| 16 | EARTH CLAMP |
| 17 | ELECTRODE HOLDER |
| 18 | HEAT SINK FOR FRD |
| 19 | QUICK CONNECTOR |
| 20 | STEEL BASE |
| 21 | IGBT |
| 22 | HEAT SINK FOR IGBT |
| 23 | TAPPING SCREW |
| 24 | FAN |
| 25 | HEAT SINK FOR BRIDGE |
| 26 | CABLE CLIP |
| 27 | SWITCH |
| 28 | FAN COVER |
| 29 | MAIN CABLE |
| 30 | SCREW |

The main board front for AW97117L

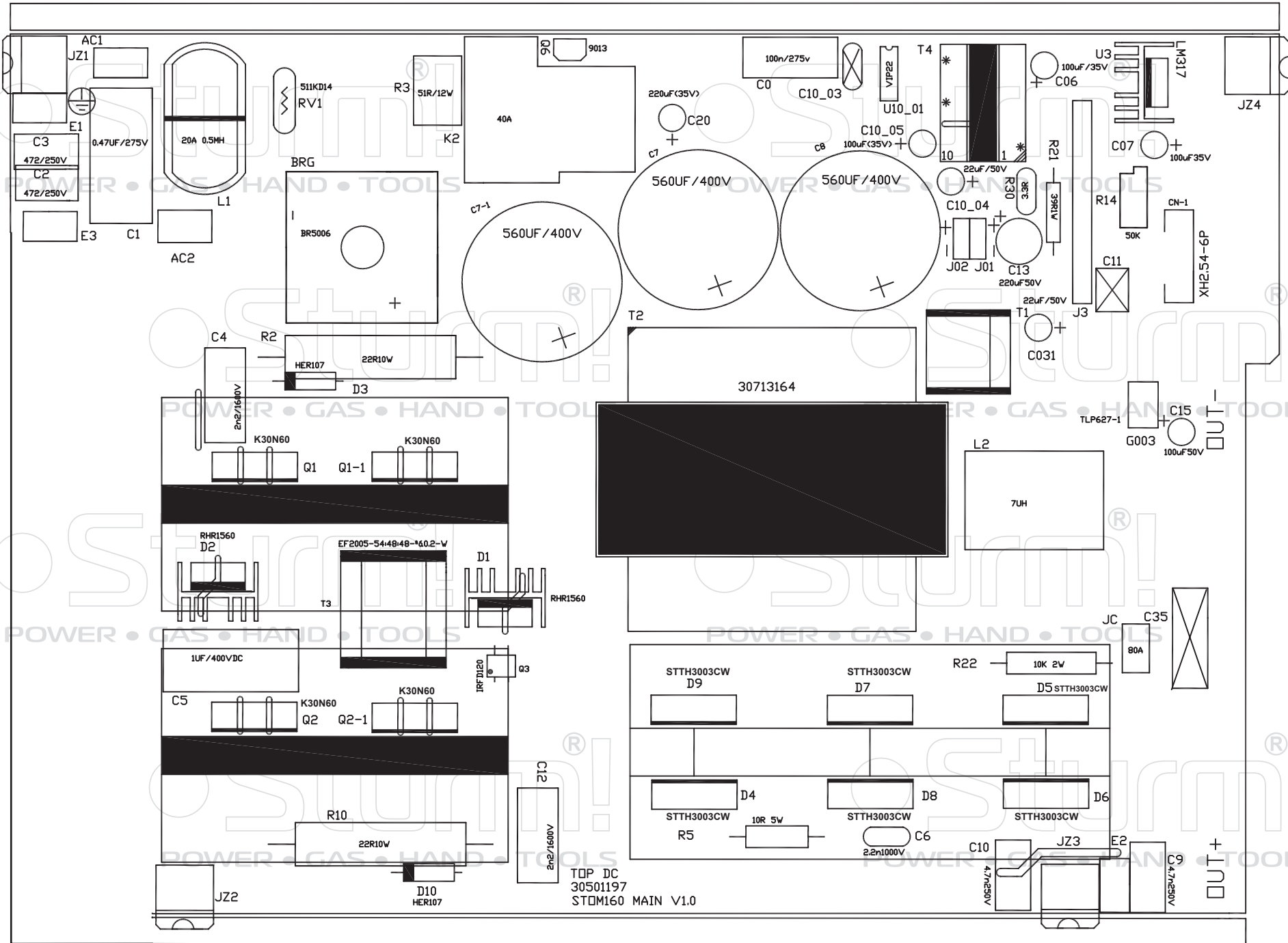

The main board back for AW97I17L

