

Sturmmaxx Sturmmaxx Sturmmaxx

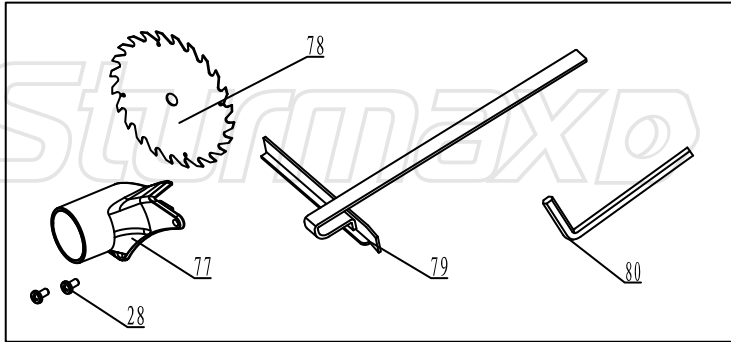
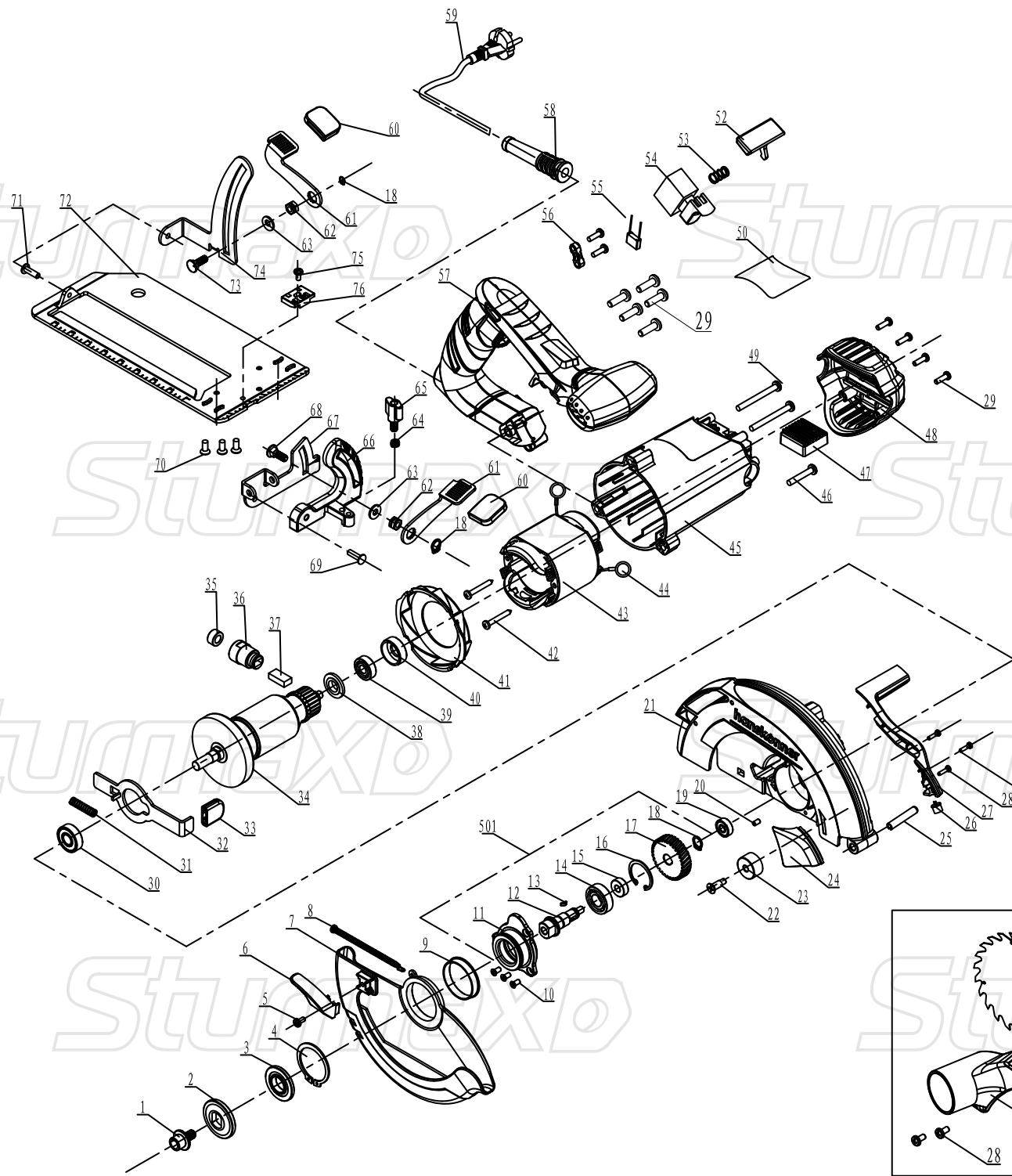

## CSM50190CP

NO.	DESCRIPTION	NO.	DESCRIPTION
1	HEXAGON FLANGE BOLT M8×14	41	WINDSHIELD
2	TOP BOARD	42	CROSS RECESSED PAN HEAD TAPPING SCREW ST4.2×55-F
3	LOWER PLATEN	43	STATOR
4	CIRCLIP FOR SHAFT37	44	TENSION SPRING
5	CROSS RECESS PAN HEAD SCREW M5×10	45	ENCLOSURE
6	ADJUSTABLE COVER WRENCH	46	CROSS RECESS PAN HEAD SCREW M5×25
7	MOVABLE SHIELD	47	CONSTANT-POWER BLOCK
8	TENSION SPRING	48	REAR COWL
9	PLASTIC JACKET	49	CROSS RECESS PAN HEAD SCREW M5×45
10	PHILLIPS COUNTERSUNK SCREW M4×10	50	PARAMETER LABELING
11	PROTEGULUM	52	SWITCH AND REVERSE LOCK LEVER
12	OUTPUT SHAFT	53	COMPRESSION SPRING $\Phi 4.7 \times \Phi 0.6 \times 5$
13	WOODRUFF KEY 3×10	54	SWITCH
14	BEARING 6001-2RS	55	CAPACITANCE
15	LOCATING STEEL BUSHING	56	CABLE CLAMP
16	CIRCLIP FOR HOLE 28	57	HANDLE
17	RACK WHEEL	58	CABLE SHEATH
18	CIRCLIP FOR SHAFT 10	59	CABLE
19	BEARING 606-2Z	60	WRENCH SLEEVE
20	RUBBER COLUMN $\Phi 4 \times 7$	61	LOCKING WRENCH
21	HEAD CAPSULE	62	SPECIAL NUT M6×6.5
22	CROSS COUNTERSUNK HEAD SHAFT POSITION SCREW M5×18	63	FLAT WASHER 6×14×1.5
23	LOCATING RETAINER	64	COMPRESSION SPRING $\Phi 7.1 \times \Phi 0.7 \times 3$
24	LAMP COVER	65	PRESS DOWN ON THE KNOB
25	ELASTIC CYLINDRICAL PIN 6×35	66	ANGLE BRACKET
26	LED LIGHT	67	ANGLE BRACKET
27	LAMPHOLDER	68	SPECIAL SQUARE NECK SCREW M6×25
28	CROSS RECESS PAN HEAD SCREW M4×8	69	SPECIAL SQUARE NECK SCREW FLAT HEAD SEMI-HOLLOW RIVET 5×16
29	CROSS PAN HEAD TAPPING SCREW ST4.2×14-F	70	PHILLIPS COUNTERSUNK SCREW M5×12
30	BEARING 6000-2RS	71	THIN FLAT HEAD SOCKET SHANK RIVET 5×9
31	COMPRESSION SPRING $\Phi 5.9 \times \Phi 0.7 \times 10$	72	ALUMINIUM BASEPLATE
32	SELF LOCK PIECE	73	SPECIAL SQUARE NECK SCREW M6×16
33	SELF-LOCKING BUTTON	74	DEPTH MOVABLE FRAME
34	ROTOR	75	CROSS RECESSED PAN HEAD WITH CUSHION SCREW M4×8
35	BRUSH HOLDER COVER	76	SAW ADJUSTER BLOCK
36	BRUSH HOLDER	77	DUST TRANSFER NOZZLE
37	CARBON BRUSH	78	SAW BLADE
38	END RING	79	GUIDE GAUGE
39	BEARING 607-2RS	80	HEX KEY 6
40	BEARING SLEEVE	501	FRONT RETAINER ASSEMBLY