

CCM9940CL

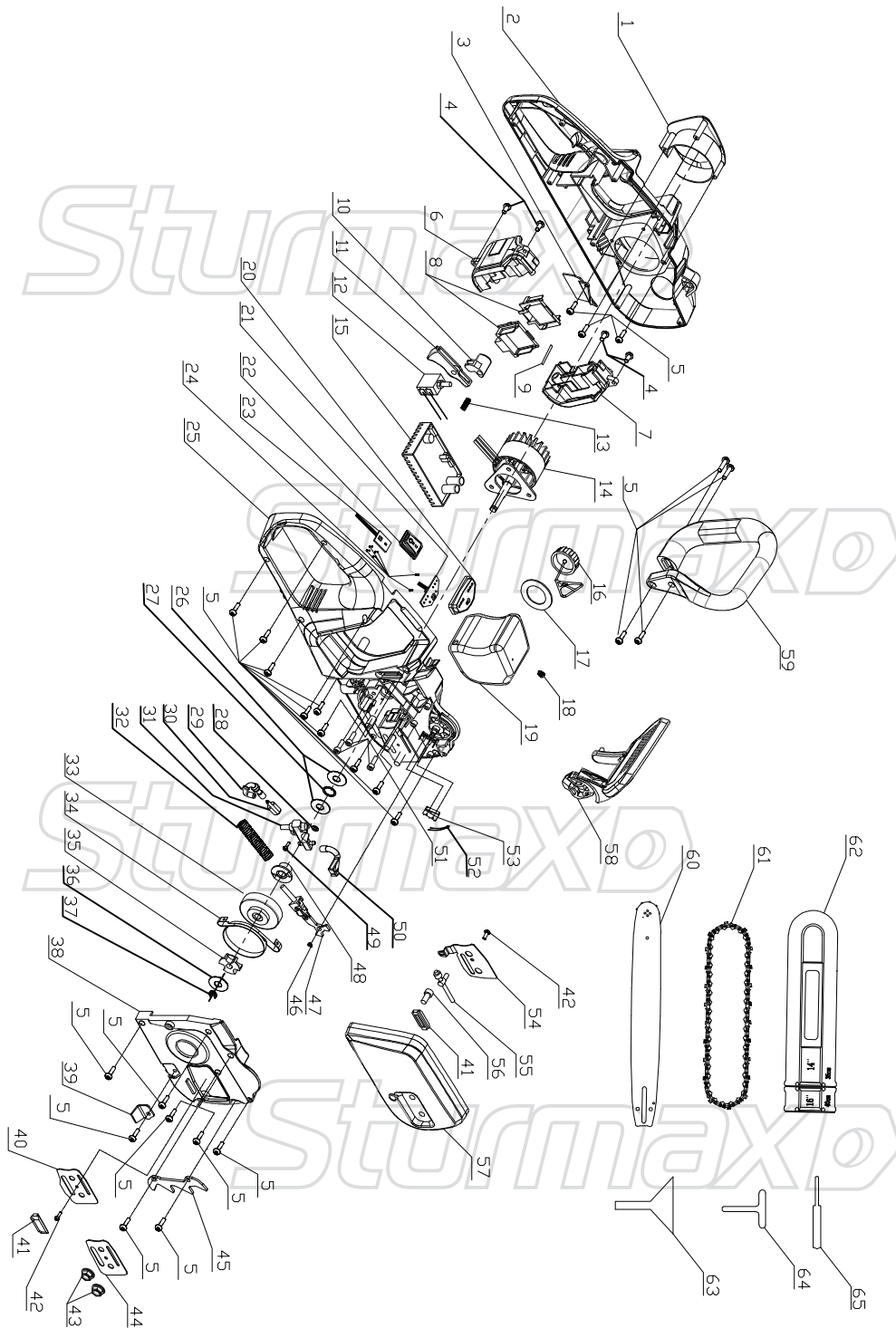

NO.	DESCRIPTION	NO.	DESCRIPTION
1	LEFT SIDE COVER	34	BRAKE STRAP
2	LEFT BOX	35	SPROCKET
3	WIND SHIELD	36	SHIM
4	SCREW	37	SNAP SPRING
5	SCREW	38	MIDDLE COVER
6	BATTERY STANDER (L)	39	CHAIN STOPPER
7	BATTERY STANDER (R)	40	OIL OUTLET COVER
8	BATTERIES SEAT	41	GUIDE CHAIN BLOCK
9	CABLE	42	SCREW
10	TRIGGER CONTROLLER	43	NUT
11	TRIGGER	44	GESKET
12	SWITCH	45	INSERTER
13	SPRING	46	SNAP SPRING
14	BRUSHLESS MOTOR	47	BRAKE LEVER ASSY
15	CONTROLLER	48	TURBINE
16	OIL CAP ASSY	49	SCREW
17	OIL TANK SEAL	50	OIL OUTLET PIPE
18	AIR VENT	51	SCREW
19	OIL TANK	52	MICROSWITCH WIRE
20	BATTERY STATUS COVER	53	MICRO SWITCH
21	BATTERY STATUS BOARD	54	BRACKER COVER
22	POWER SWITCH COVER	55	DRIVING GEAR
23	POWER SWITCH BOARD	56	PASSIVE GEAR
24	SCREW	57	RIGHT LEFT COVER
25	RIGHT BOX	58	FRONT BAFFLE
26	SHIM	59	HANDLE
27	O-RING	60	BAR
28	SHIM	61	CHAIN
29	OIL INLET PIPE	62	BAR COVER
30	OIL FILTER	63	FUNNEL
31	OIL PUMP	64	SLEEVE
32	BRACKER SPRING	65	SCREWDRIVER
33	PASSIVE DISK		

CCM9940CL-EX-UK240304-1