

SCM2016CL

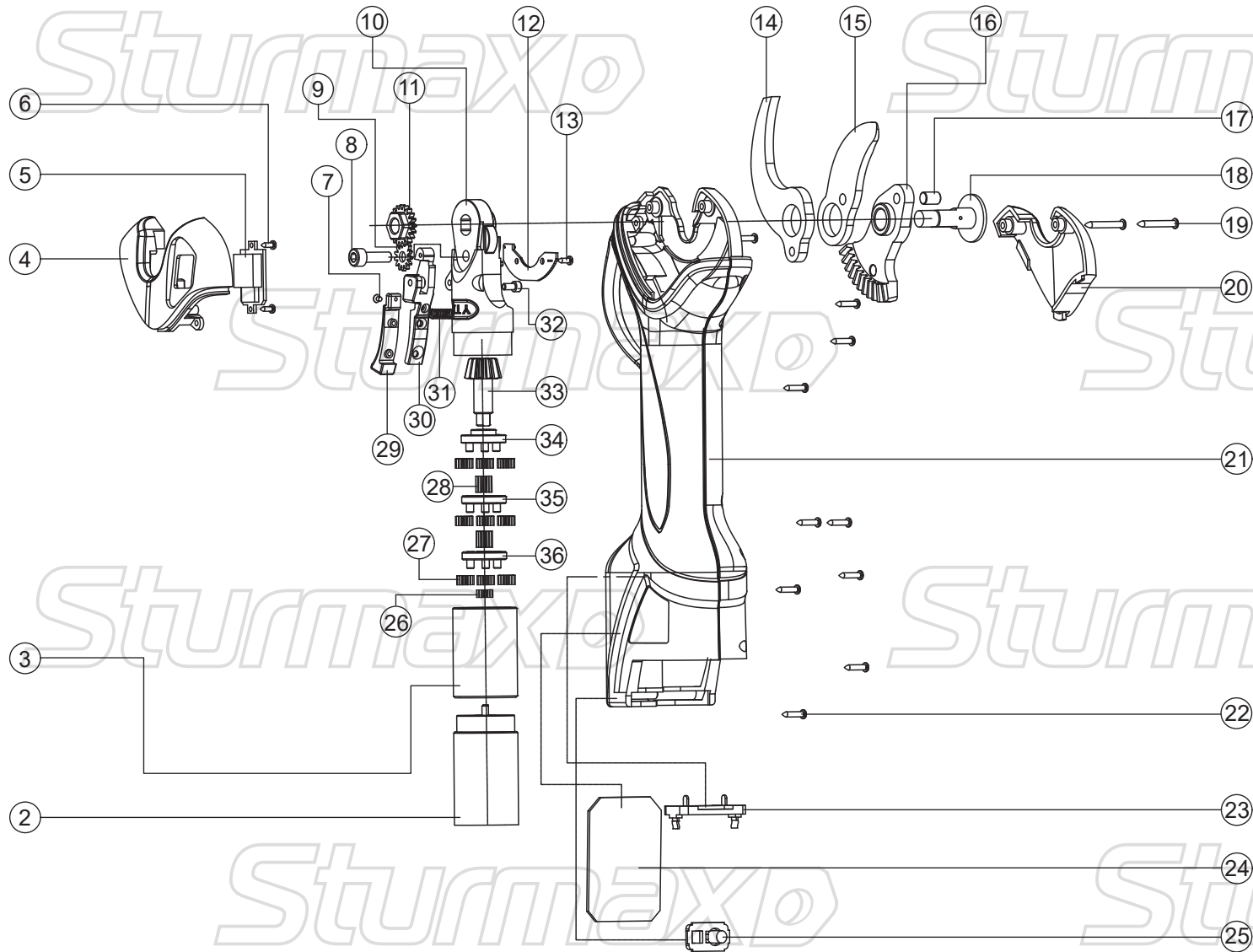

NO.	DESCRIPTION
2	MOTOR
3	GEAR BOX
4	LEFT HOUSE TOP COVER
5	DISPLAY SCREEN
6	SCREW
7	SCREW
8	SCREW
9	TOOTH-SHAPED GASKET
10	TOOTH-SHAPED NUT
11	SCISSOR HEAD
12	SCISSOR COLLTROLLER
13	SCREW
14	FIXED KNIFE
15	WORKING KNIFE
16	SWINGING GEAR
17	SWINGING GEAR PIN
18	KNIFE SHAFT ASSY
19	SCREW
20	RIGHT HOUSE TOP COVER
21	HOUSE
22	SCREW
23	BATTERY SEAT
24	MOTOR CONTROLLER
25	POWER SWITCH
26	MOTOR GEAR
27	PLANETARY GEARS
28	SOLAR GEARS
29	TRIGGER COVER
30	TRIGGER
31	SPRING
32	SCREW
33	BEVEL GEARS
34	GEAR SUPPORTER 2
35	GEAR SUPPORTER 1
36	GEAR SUPPORTER 1