

SCM2016CLSS

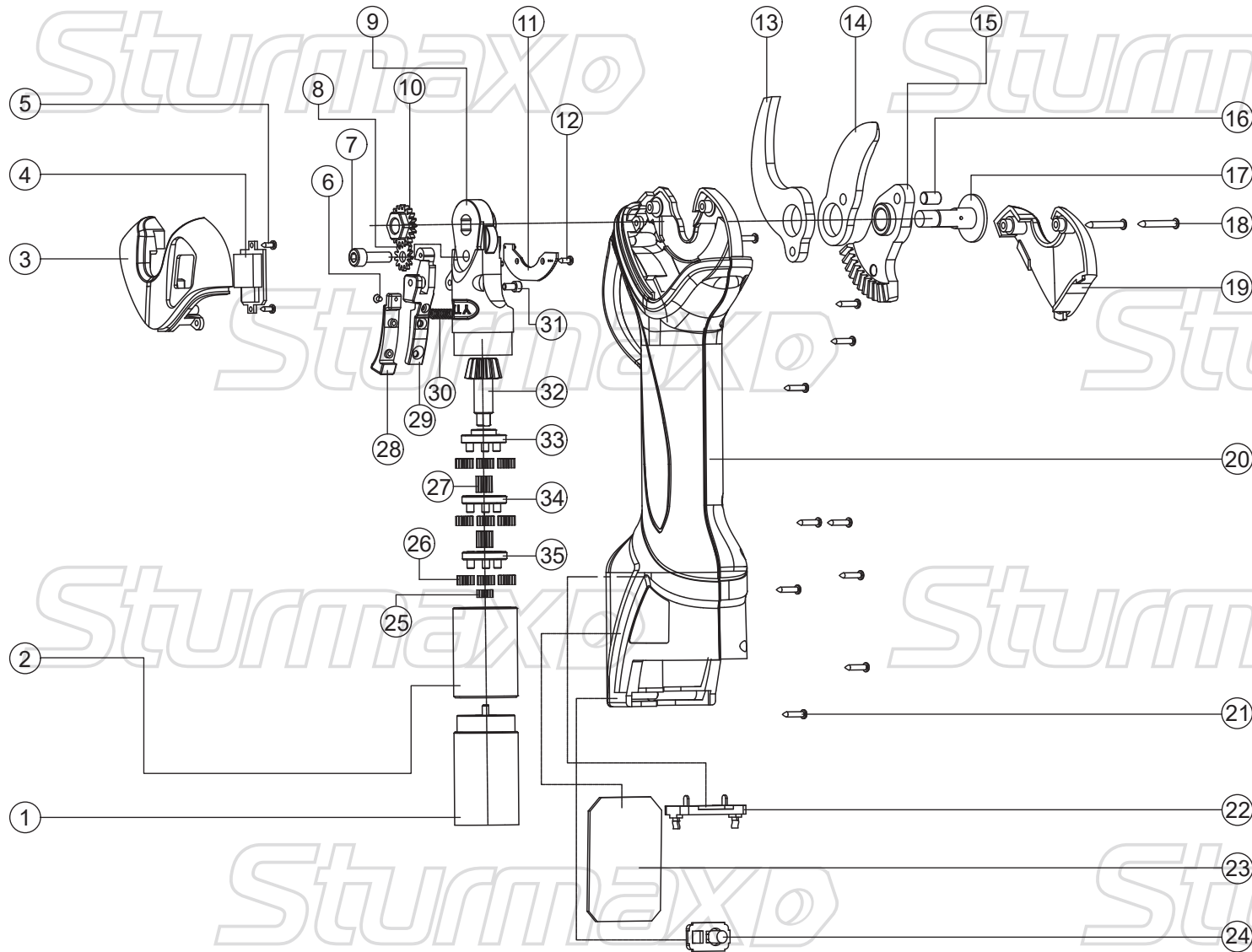

NO.	DESCRIPTION
1	MOTOR
2	GEAR BOX
3	LEFT HOUSE TOP COVER
4	DISPLAY SCREEN
5	SCREW
6	SCREW
7	SCREW
8	TOOTH-SHAPED GASKET
9	TOOTH-SHAPED NUT
10	SCISSOR HEAD
11	SCISSOR COLLROLLER
12	SCREW
13	FIXED KNIFE
14	WORKING KNIFE
15	SWINGING GEAR
16	SWINGING GEAR PIN
17	KNIFE SHAFT ASSY
18	SCREW
19	RIGHT HOUSE TOP COVER
20	HOUSE
21	SCREW
22	BATTERY SEAT
23	MOTOR CONTROLLER
24	POWER SWITCH
25	MOTOR GEAR
26	PLANETARY GEARS
27	SOLAR GEARS
28	TRIGGER COVER
29	TRIGGER
30	SPRING
31	SCREW
32	BEVEL GEARS
33	GEAR SUPPORTER 2
34	GEAR SUPPORTER 1
35	GEAR SUPPORTER 1

CCM9916SS

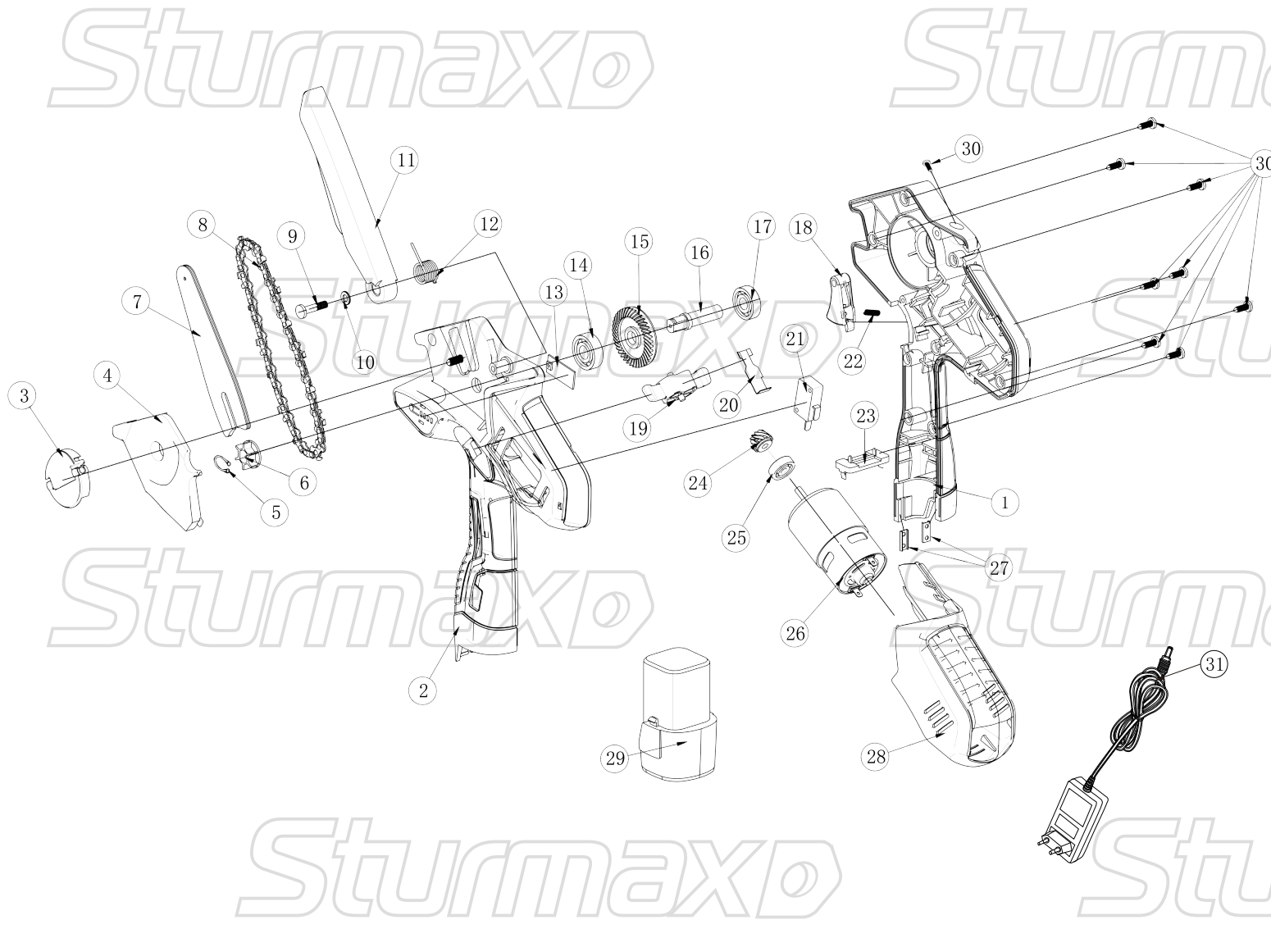

NO.	DESCRIPTION
1	MHOUSE(RIGHT)
2	HOUSE(LEFT)
3	LOCK NUT
4	SIDE COVER
5	CIRCLIP
6	SPROCKET
7	BAR
8	CHAIN
9	SCREW
10	SHIM
11	PROTECTOR
12	PROTECTOR SPRING
13	POWER DISPLAY CIRCUIT BOARD
14	BEARING 6000
15	GEAR 35T
16	OUTPUT SHAFT
17	BEARING 609
18	TRIGGER
19	TRIGGER CONTROLLER
20	TRIGGER CONTROLLER SPRING
21	MICRO SWITCH
22	TRIGGER SPRING
23	BATTERY PINS
24	GEAR 11T
25	BEARING 635
26	MOTOR 775
27	LOCKER
28	TOP COVER
29	BATTERY
30	SCREW
31	CHARGER