

DWSM6075SLM

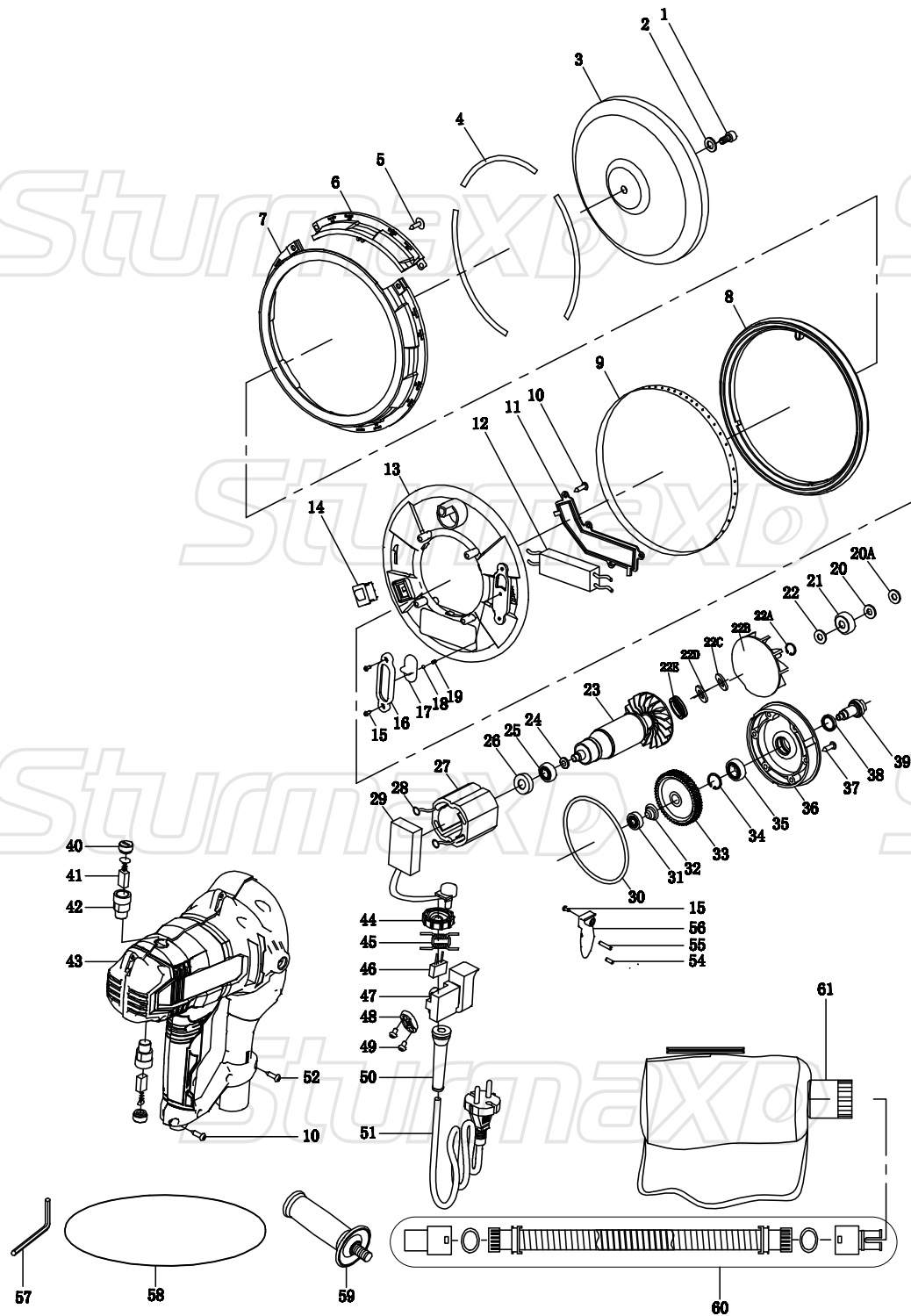

NO.	DESCRIPTION	NO.	DESCRIPTION
1	SCREW M6×16	28	CONDUCTING RING 2.8
2	WASHER Φ6	29	VARIABLE SPEED SWITCH
3	SANDING PAD Φ180	30	PAPER WASHER Φ80×Φ85×0.5
4	PROTECTION PIECE	31	BEARING 606-2Z
5	SCREW ST3.9×12	32	SPRING Φ1
6	SIDE SEGMENT PA6+GF30%	33	BIG GEAR 40CR
7	BIG GUARD PA6+GF30%	34	CIRCLIP Φ26
8	LED LIGHT COVER	35	BEARING 6000-2RS
9	LED LIGHT 550MM	36	GEAR BOX ADC12
10	SCREW ST3.9×10	37	TAPPING SCREW ST3.9×18
11	LED LIGHT DRIVER COVER ABS	38	SEAL RING 18×24×3
12	LED LIGHT DRIVER	39	SPINDLE 45#
13	SANDING PAD COVER ABS	40	BRUSH COVER M10
14	LED SWITCH	41	CARBON BRUSH 6X9X12.5
15	SCREW ST3×10	42	BRUSH HOLDER 6X9
16	PRESS BOARD ABS	43	HOUSING PA6+GF30%
17	PUSH BLOCK ABS	44	VARIABLE SPEED KNOB PA6+GF30%
18	STEEL BALL Φ3	45	INDUCTOR 24
19	SPRING Φ2.5XΦ0.4X9.5	46	CAPACITOR 2×0.33UF
20	WOOL RING Φ9×Φ20×2	47	SWITCH FA1-6C-1108
20A	WASHER Φ9.5×Φ20×1	48	CABLE CLAMP PA6+GF30%
21	WASHER 608-2RS	49	TAPPING SCREW ST3.9×14
22	SEAL RING Φ10×Φ20×5	50	CABLE SLEEVE
22A	CIRCLIP Φ12	51	CABLE 2X0.75X3.5
22B	FAN	52	TAPPING SCREW ST3.9×16
22C	WOOL RING Φ12XΦ22X1	54	RUBBER PIN 4×10
22D	WOOL RING Φ12XΦ20X0.5	55	PIN Φ3×14
22E	ANTI-DUST RING	56	WIND GUIDE ABS
23	ROTOR	57	ALLEN KEY 5MM
24	WASHER Φ7.2XΦ12X1	58	SANDER PAPER Φ180
25	BIG 607-2RS	59	SIDE HANDLE M10
26	BEARING BUSH Φ19	60	SOFT TUBE
27	STATOR Φ56X45	61	DUST BAG

DWSM6075SLM-EX-UKW211014