

ERM1122E

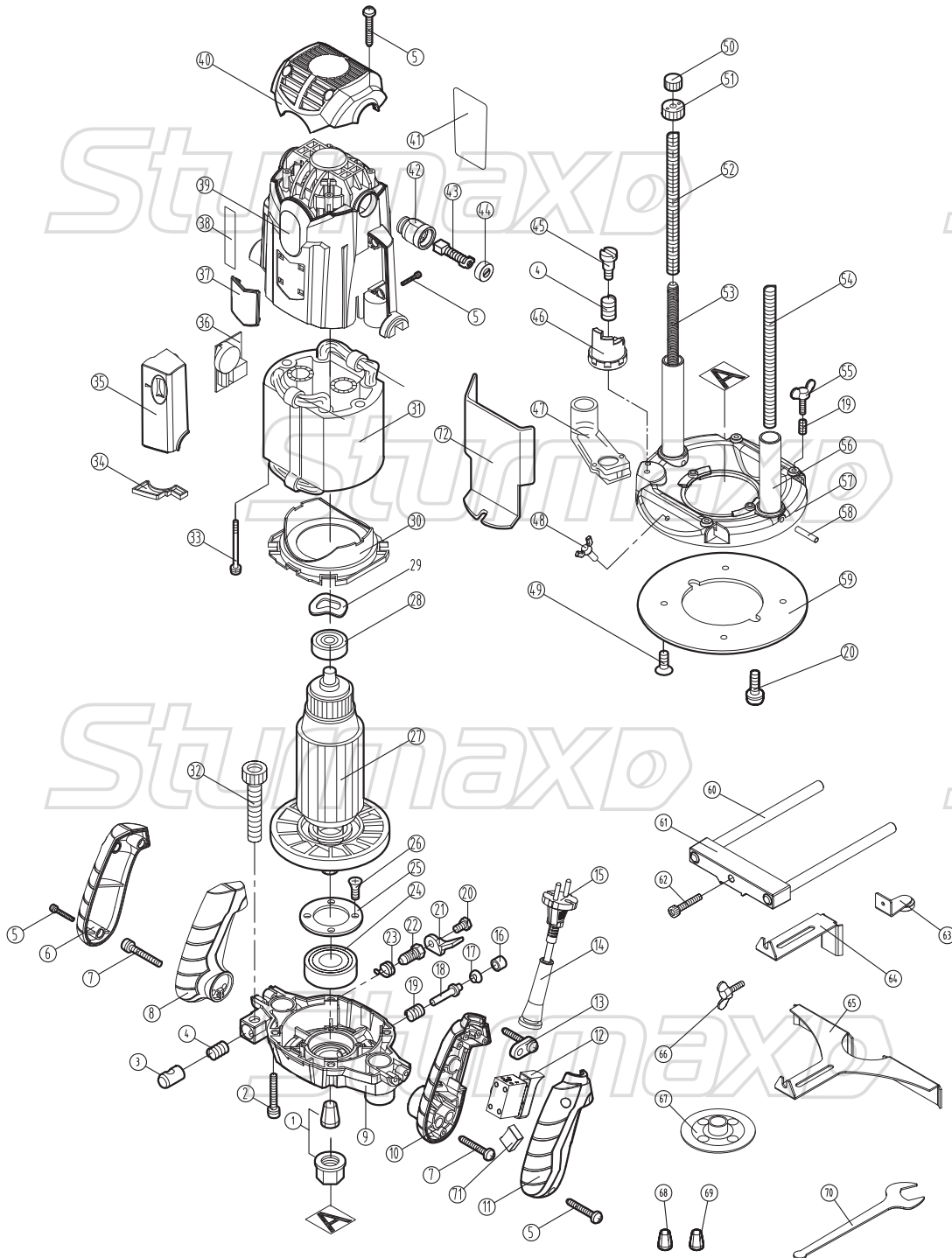

NO.	DESCRIPTION	NO.	DESCRIPTION
1	COLLET 12mm	37	LABEL
2	SCREW/ST5X22	38	SCALE LABEL
3	ROUND NUT/φ14x19	39	HOUSING
4	COMPRESSION SPRING/φ14Xφ	40	BEAR COVER
5	SCREW/ST4X16	41	LABEL
6	LEFT HANDLE COVER	42	BRUSH HOLDER
7	SCREW/M5X18	43	CARBON BRUSH
8	RIGHT HANDLE SEAT	44	CAP OF BRUSH HOLDER
9	HEAD HOUSING	45	AXIS SCREW
10	RIGHT HANDLE SEAT	46	HEIGHT BLOCK
11	RIGHT HANDLE COVER	47	DUST TUBE
12	SWITCH	48	BUTTERFLY SCREW/M5X10
13	STRAIN RELIEF	49	SCREW/M5X10
14	CORD GUARD	50	FINE TUNING CAP/M10Xφ16X12
15	CORD	51	FINE TUNING KNOB
16	CAP OF LOCK	52	GUIDE PIN SPRING (LONG)
17	CIRCLIP/φ12	53	LONG GUIDE PILLAR
18	LOCK PIN	54	GUIDE PIN SPRING (SHORT)
19	COMPRESSION SPRING/φ8Xφ	55	BUTTERFLY SCREW/M5X16
20	SCREW/M5X10	56	SHORT GUIDE PILLAR
21	LOCK WRENCH	57	SEAT
22	LOCK SCREW	58	ELASTIC CYLINDER PIN
23	COMPRESSION SPRING	59	BASE
24	BEARING 6004 2RS	60	PARALLEL GUIDE/φ12x200
25	BEARING COVER	61	PARALLEL LOCATING SEAT
26	SCREW/M4X10	62	ADJUST SCREW/M10X40
27	ARMATURE	63	TRIM GUIDE
28	BEARING 6200 2RS	64	GUIDE BRACKET
29	WAVE PAD/φ29	65	PARALLEL GUIDE
30	WIND CIRCLE	66	BUTTERFLY SCREW/M6X10
31	STATOR	67	SAMPLE GAUGE GUIDE
32	ADJUST SCREW/M10X80	68	COLLET/6mm
33	SCREW/ST5X70-C	69	COLLET/8mm
34	BAFFLE	70	WRENCH/24
35	SPEEDER COVER	71	CAPACITANCE
36	SPEEDER	72	DUST COVER

ERM1122E-EX-UK241010-1