

GTM3620

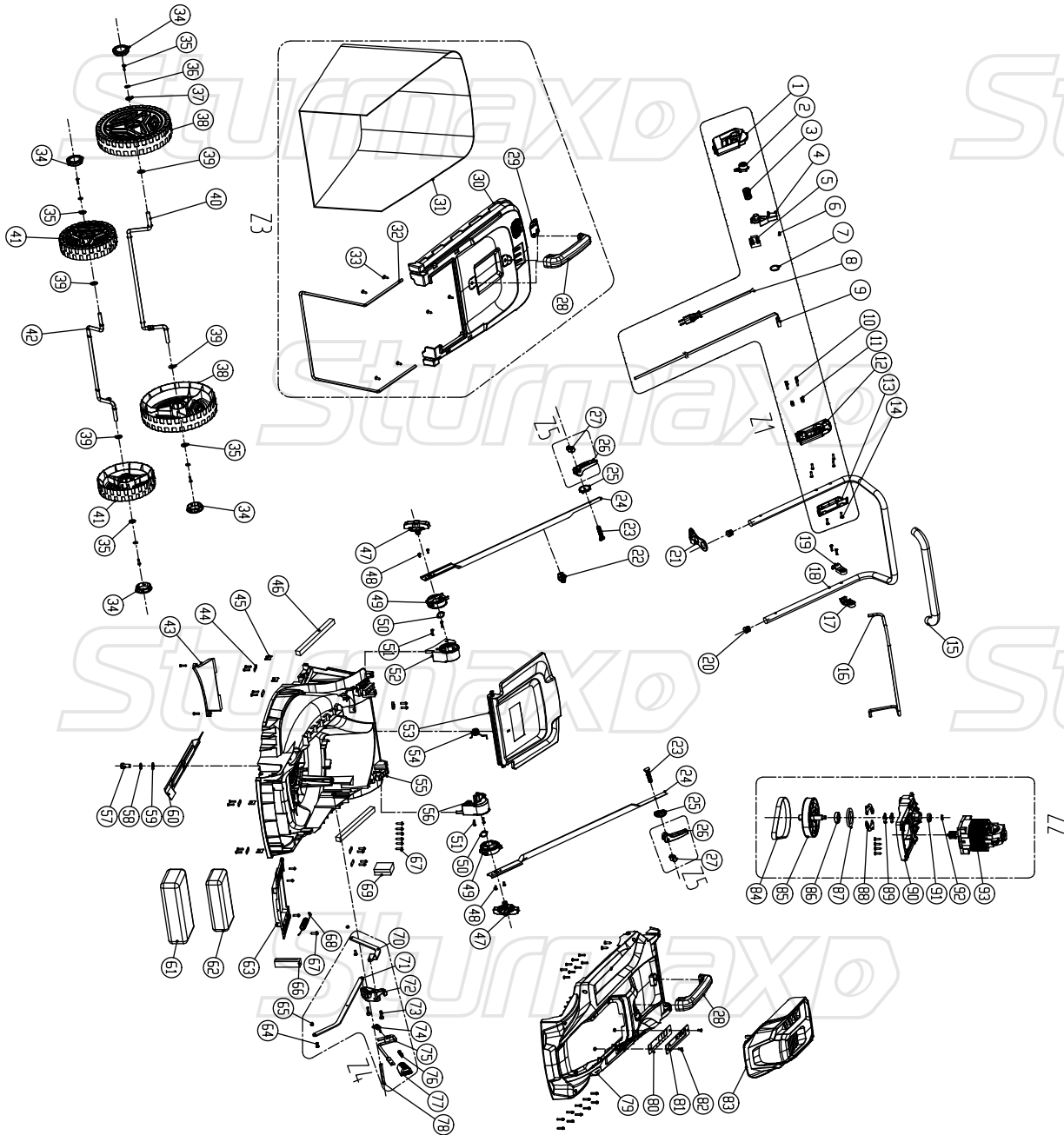

NO.	DESCRIPTION	NO.	DESCRIPTION
1	UPPER COVER OF THE SWITCH BOX	50	Φ 13 RING
2	SWITCH BOX PUSH BUTTON	51	ST4.8 * 18-C BOLT
3	SPRING OF SWITCH-BOX	52	RIGHT ADJUSTMENT FIXING WHEEL
4	SWITCH THE ROCKER LEVER	53	REAR COVER
5	ST3.5 * 10-C SCREW	54	SPRING OF REAR COVER PLATE
6	SWITCH	55	DECK
7	TORSION SPRING OF SWITCH TRIGGER 2	56	LEFT ADJUSTMENT FIXING WHEEL
8	CABLE	57	M10 * 20 BOLT
9	CAPACITOR COMPONENT	58	Φ 10 WASHER
10	SCREW ST4.2*16	59	WASHER Φ10
11	PLATE	60	BLADE 2
12	SWITCH BOX BASE	61	SAND BAG
13	SWITCH BOX FIXED COVER	62	SAND
14	SCREW ST4.2*19	63	SANDBOX COVER
15	FOAM OF UPPER HANDLE	64	M5 BOLT 2
16	SWITCH PULL ROD	65	NUT M5
17	SWITCH LEVER SUPPORT SEAT (LEFT)	66	SPONGE
18	UPPER HANDLE	67	SCREW ST4.8X19
19	SWITCH LEVER SUPPORT SEAT (RIGHT)	68	FRONT AXLE SPRING
20	PLUG ON LOWER HANDLE	69	SPONGE
21	CABLE CLIP1	70	PULL ROD OF REAR AXLE
22	CABLE CLIP2	71	PULL ROD OF FRONT AXLE
23	BOLT M6*45	72	HEIGHT ADJUSTMENT BLOCK
24	LOWER HANDLE	73	M6 BOLTS
25	PLASTIC WASHER	74	HEIGHT ADJUSTMENT SPRING
26	QUICK CLIP HANDLE	75	HEIGHT ADJUSTMENT LINK BAR
27	QUICK CLIP HANDLE SHAFT 1	76	SCREW ST4.8*10
28	HANDLE ON UPPER COVER	77	HEIGHT ADJUSTMENT HANDLE
29	GRASS INDICATOR	78	REAR WHEEL AXLE
30	COVER OF GRASS COLLECTION	79	COVER
31	GRASS BAG	80	LINK BAR OCCULTING BAR
32	GRASS BAG FRAME	81	5 LEVELS PLATE
33	M6 * 12 SCREW	82	BOLT M5*10
34	Φ 6 WASHER	83	MOTOR COVER
35	M6*12 BOLT	84	BELT 2
36	Φ 6 WASHER	85	LARGE BELT PULLEY ASSEMBLY
37	BIG WASHER Φ6	86	6002-2RS BEARING
38	REAR WHEEL	87	BRAKE RING
39	Φ 10 FLAT GASKET	88	BRAKE PADS
40	REAR WHEEL SHAFT ASSEMBLY	89	BRAKE SPRING
41	FRONT WHEEL	90	REDUCER GEARBOX BRACKET
42	FRONT AXLE ASSEMBLY	91	609-2Z BEARING
43	GRASS GUIDE COVER	92	Φ 9 RING
44	WHEEL AXLE PLATE	93	MOTOR
45	WHEEL AXLE BAFFLE	Z1	SWITH BOX ASSEMBLY
46	SPONGE	Z2	REDUCTION GEARBOX ASSEMBLY 2
47	LOCK NUT	Z3	GRASS BAG ASSEMBLY
48	ST4.2*9.5-F BOLT	Z4	HEIGHT ADJUSTMENT ASSEMBLY
49	ADJUSTMENT MOVING WHEEL	Z5	QUICK CLAMP ASSEMBLY