

# IDM21158MV

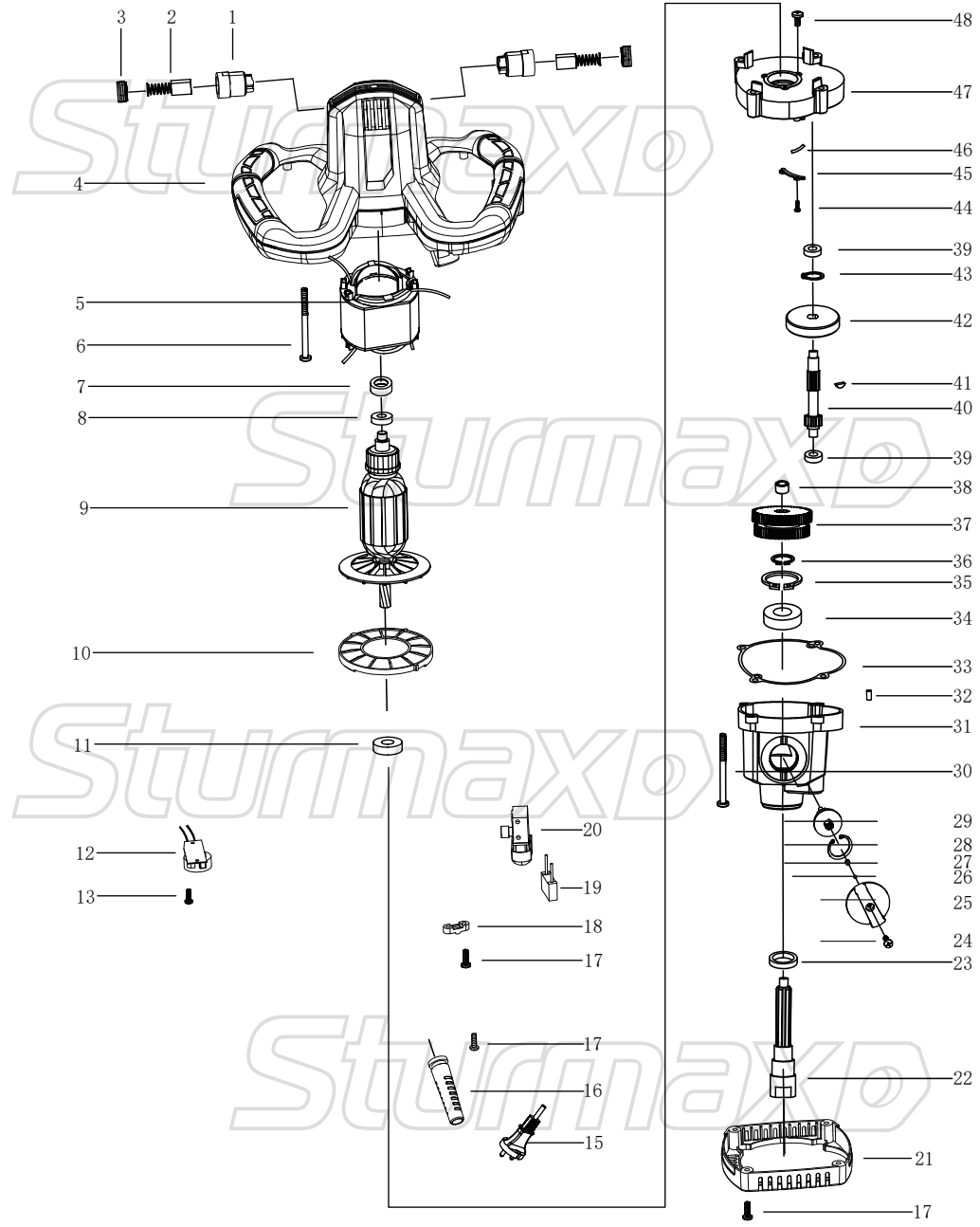

NO.	DESCRIPTION	NO.	DESCRIPTION
1	CARBON BRUSH HOLDER	35	CRICLIP $\Phi 35$
2	CARBON BRUSH	36	CRICLIP $\Phi 17$
3	BRUSH COVER	37	SECOND DRIVEN GEAR
4	HOUSING	38	NEEDLE ROLLER BEARING HK0808
5	STATOR	39	BEARING 698Z
6	SCREW ST4.8*60	40	SECOND GEAR SHAFT
7	BEARING COVER	41	WOODRUFF KEY 3X10
8	BEARING 608Z	42	HELICAL GEAR
9	ROTOR	43	CRICLIP $\Phi 10$
10	WIND FENDER	44	SCREW M3*8
11	BEARING 6001Z	45	OIL STORE COVER
12	VARIABLE SPEED SWITCH	46	OIL ABSORPTION PIECE
13	SCREW ST2.9*6.5	47	MIDDLE COVER
15	CABLE	48	SCREW M4*6
16	CABLE SLEEVE		
17	SCREW ST3.9*14		
18	CABLE CLAMP		
19	CAPACITOR 0.33UF		
20	SWITCH		
21	WIND COVER		
22	OUTPUT SHAFT		
23	OIL SEAL 21X26X5		
24	SCREW M4*12		
25	TWO SPEED CHANGE KNOB		
26	STEEL BALL $\Phi 4$		
27	SPRING		
28	CRICLIP $\Phi 35$		
29	TWO SPEED CHANGE SHAFT		
30	SCREW ST4.8*50		
31	GEAR BOX		
32	PIN $\Phi 4 \times 8$		
33	SEALING RING		
34	BEARING 6003Z		

IDM21158MV-EX-UK241010-1