

VCM7215A

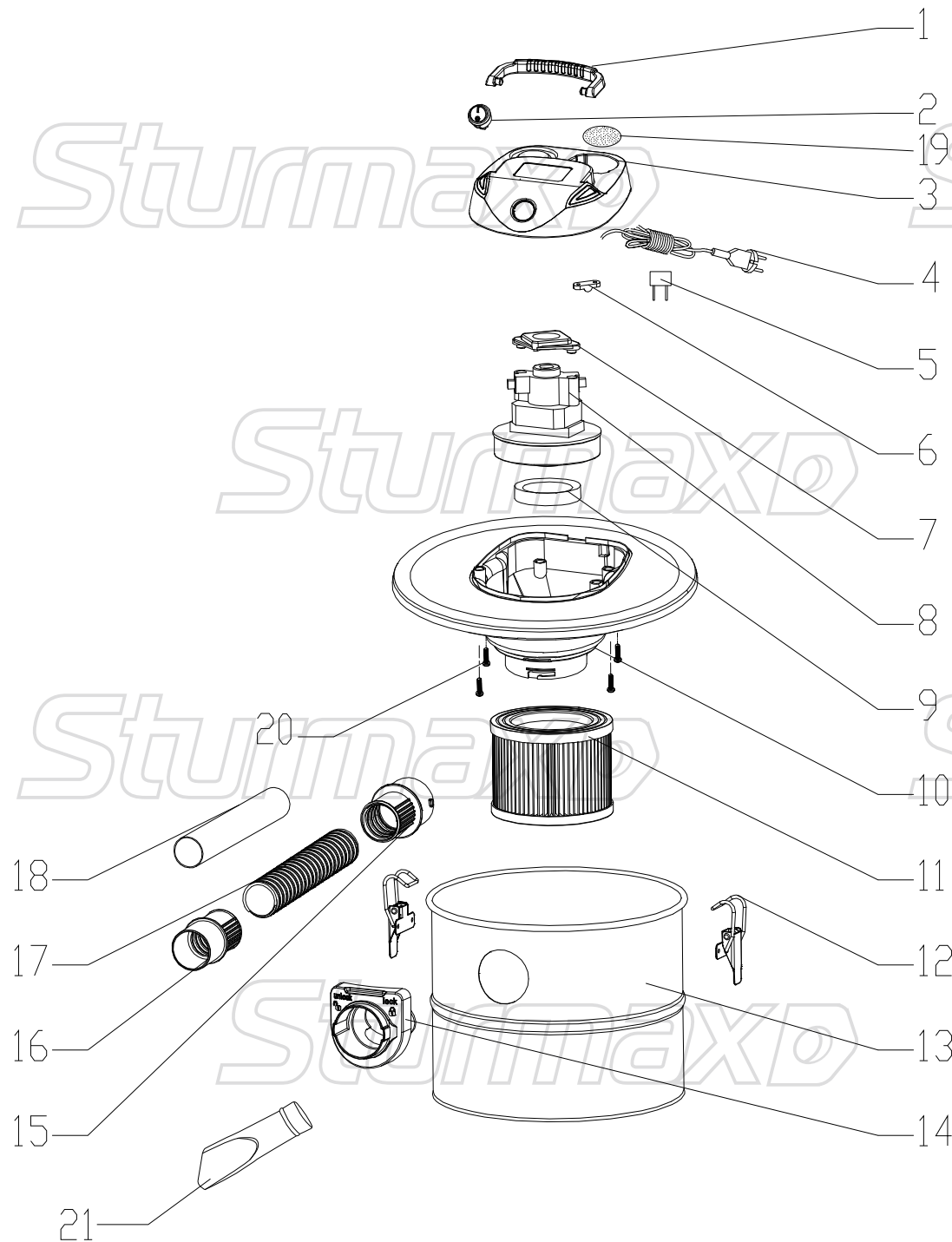

No	DESCRIPTION
1	HANDLE
2	SWITCH
3	TOP COVER
4	POWER CABLE
5	CAPACITOR
6	CABLE CLAMP
7	MOTOR PRESS BOARD
8	MOTOR
9	MOTOR SEAL
10	DOWN COVER
11	HEPA FILTER
12	CLAMP SET
13	TANK
14	INLET SEAT
15	HOSE CONNECTION HEAD
16	HUSE
17	METAL HOSE
18	ALUNINUM TUBE
19	SPONGE
20	SCREW
21	CREVICE NOZZLE