

WMM1915 Part List LT00

NO.	DESCRIPTION	NO.	DESCRIPTION
1	L-SHAPE BOLT 1	5	RUBBER WASHER
2	LOCKING KNOB	6	L-SHAPE BOLT 2
3	SCREW	7	RIP FENCE
4	SQUARE WASHER	8N	SWITCH

WMM1915-EX-UKW230411

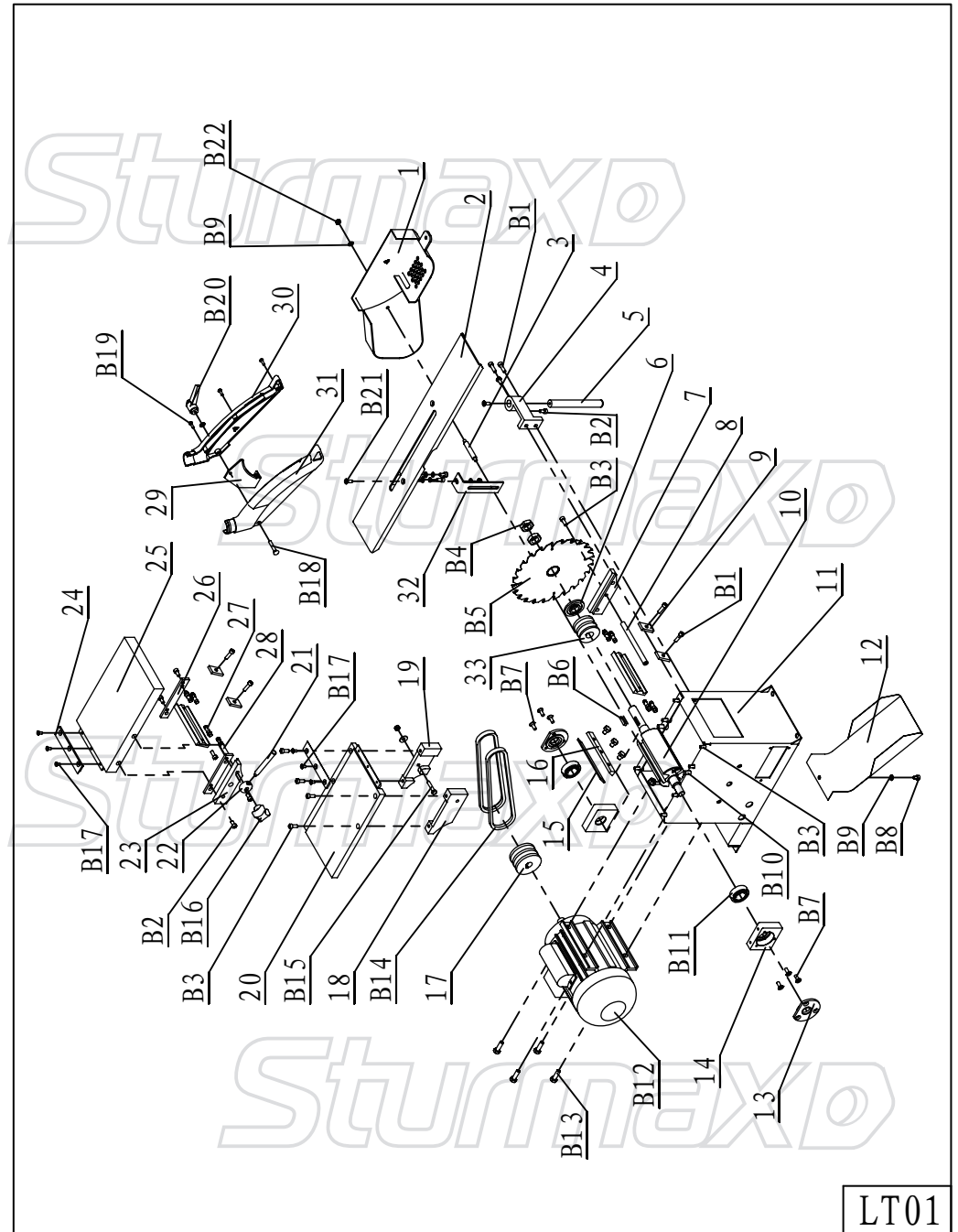

LT01

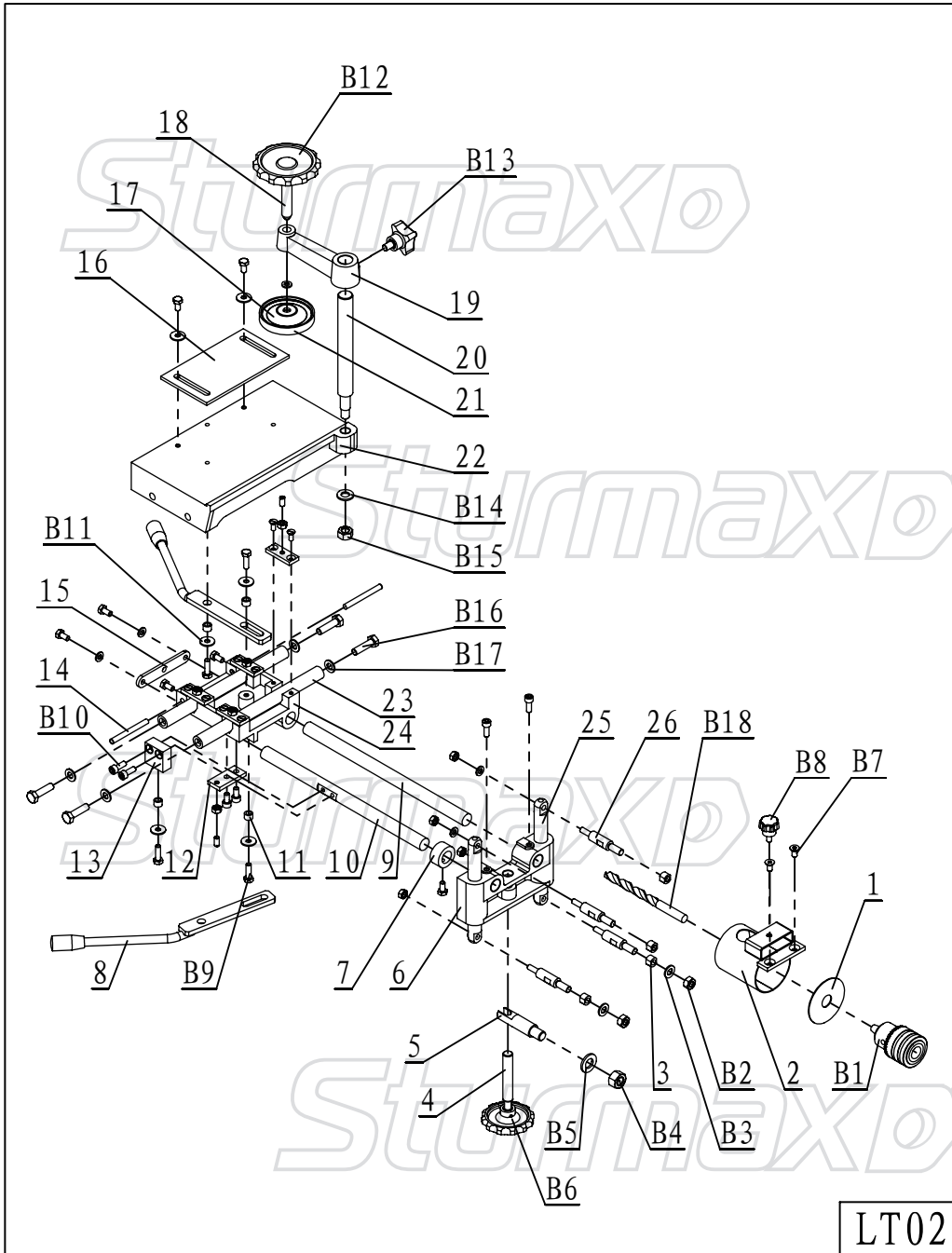

WMM1915 Part List LT01

NO.	DESCRIPTION	NO.	DESCRIPTION
1	SAW BLADE DOWN GUARD	29	RIVING KNIFE
2	SAW WORKTABLE	30	RIGHT SAW GUARD
3	GUARD SUPPORT POLE	31	LEFT SAW GUARD
4	WORKTABLE SUPPORT	32	SAW WORKTABLE SUPPORT
5	WORKTABLE BRACE	33	BELT PULLEY
6	SAW BLADE FLANGE	B1	SCREW M6X20
7	FRONT PLANING WORKTABLE RIGHT SLIDE	B2	SCREW M6X12
8	SUPPORT SHAFT	B3	SCREW M6X16
9	PRESS BOARD	B4	NUT M18X1.5
10	ARBOR	B5	SAW BLADE
11	BASE	B6	KEY
12	DUST BOARD	B7	SCREW M6X16
13	BEARING COVER	B8	SCREW M6X8
14	BEARING HOLDER	B9	WASHER
15	BLADE	B10	SCREW M8X16
16	BLADE PRESS BOARD	B11	BEARING 6004Z
17	MOTOR PULLEY	B12	MOTOR
18	BACK PLANING WORKTABLE LEFT SLIDE	B13	BOLT M8X25
19	BACK PLANING WORKTABLE RIGHT SLIDE	B14	BELT
20	BACK PLANING WORKTABLE	B15	BOLT M6X30
21	PLANING DEPTH ADJUSTMENT HANDLE	B16	LOCKING KNOB
22	HANDLE HOLDER	B17	SCREW M5X10
23	FRONT PLANING WORKTABLE LEFT SLIDE	B18	BOLT M6X35
24	PRESS BOARD	B19	SCREW ST4.2X16
25	FRONT PLANING WORKTABLE	B20	LOCKING HANDLE
26	LIFTING BOARD	B21	SCREW M6X16
27	SWING ARM	B22	NUT M6
28	LIFTING SHAFT		

WMM1915 Part List LT02

NO.	DESCRIPTION	NO.	DESCRIPTION
1	COVER	23	ROUND GUIDE RAIL 3
2	DRILLING GUARD	24	SUPPORT BOARD
3	NUT	25	ROUND GUIDE RAIL 4
4	LIFTING SHAFT	26	BOLT
5	SUPPORT POLE	B1	CHUCK
6	BRACKET	B2	NUT M8
7	HOLDING RING	B3	WASHER
8	HANDLE	B4	NUT M12
9	ROUND GUIDE RAIL 1	B5	WASHER
10	ROUND GUIDE RAIL 2	B6	HAND WHEEL
11	PRESS BUSH	B7	SCREW M6X12
12	PRESS BOARD	B8	LOCKING KNOB
13	SUPPORT	B9	BOLT M6X20
14	HOLDING POLE	B10	SCREW M6X16
15	FIXING BOARD	B11	WASHER
16	LOCATING BOARD	B12	HAND WHEEL
17	WORKPIECE CLAMP	B13	LOCKING KNOB
18	SCREW/SHAFT	B14	WASHER
19	SWING ARM	B15	NUT M10
20	PILLAR	B16	BOLT M8X30
21	WORKPIECE CLAMP COVER	B17	WASHER
22	DRILLING BENCH	B18	DRILL BIT