

SturmaxD

WPM97305

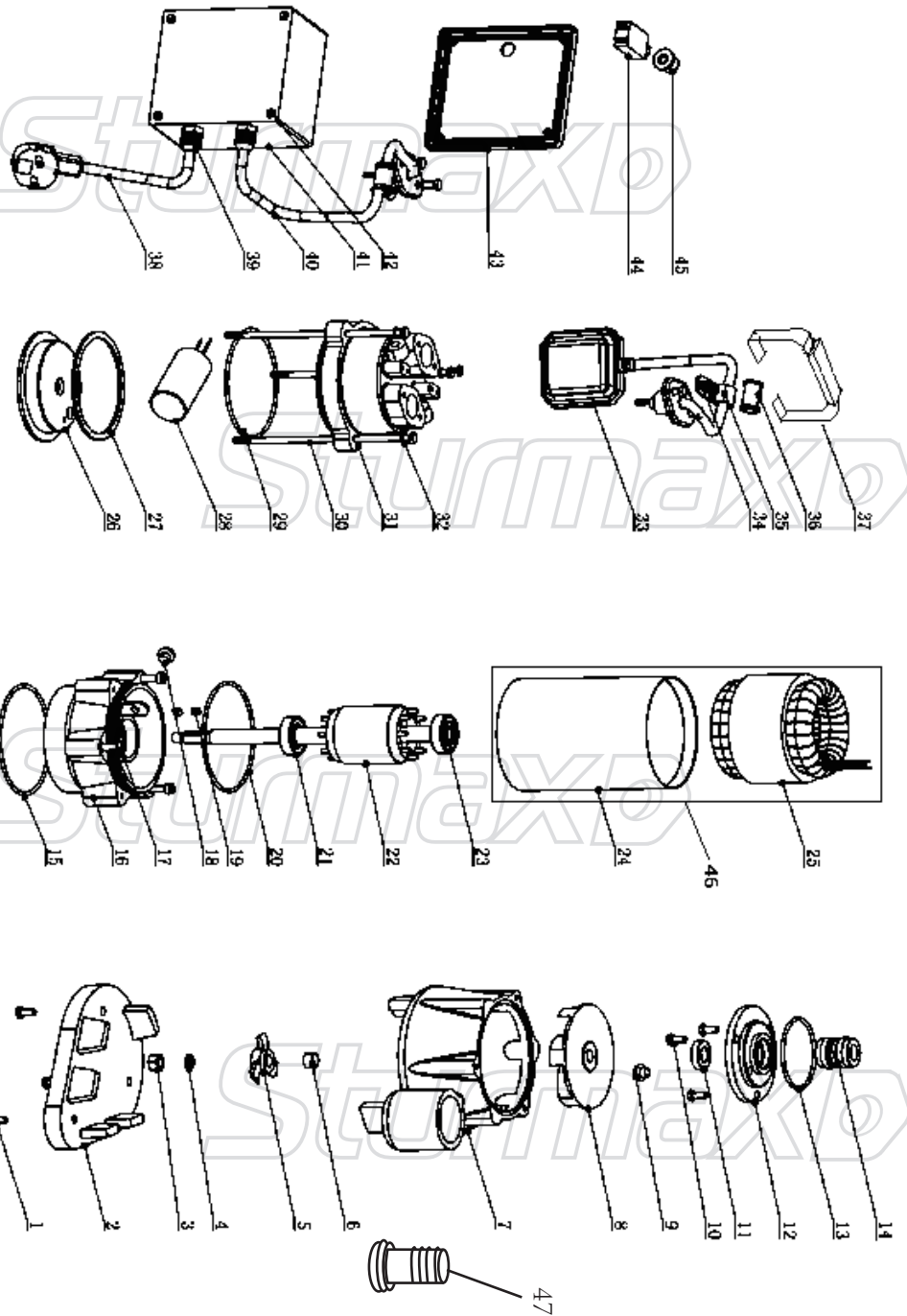

NO.	DESCRIPTION	NO.	DESCRIPTION
1	SCREW	24	MOTOR HOUSING
2	FILTER BOTTOM	25	STATOR WITH WIRE
3	NUT	26	COVER PLATE
4	WASHER	27	"O" RING
5	CUTTING BLADE	28	CAPACITOR
6	SHAFT SLEEVE	29	"O" RING
7	PUMP BODY	30	SCREW
8	IMPELLER	31	TOP COVER
9	NUT	32	WASHER
10	SCREW	33	FLOW SWITCH
11	OIL SEAL	34	SCREW
12	BOTTOM COVER	35	CABLE PRESSER
13	"O" RING	36	CABLE PROTECTOR
14	MECHANICAL SEAL	37	HANDLE
15	"O" RING	38	PLUG
16	OIL CHAMBER	39	CABLE PROTECTOR
17	SCREW	40	CABLE
18	NUT	41	PROTECTOR BOX
19	PIN	42	SCREW
20	"O" RING	43	PROTECTOR COVER
21	BEARING	44	CURRENT OVERLOAD PROTECTOR
22	ROTOR	45	RUBBER COVER
23	BEARING	46	HOUSING WITH STATOR
		47	WATER OUTLET

WPM97305-EX-UK250109-1

SturmaxD