

BP-8755X

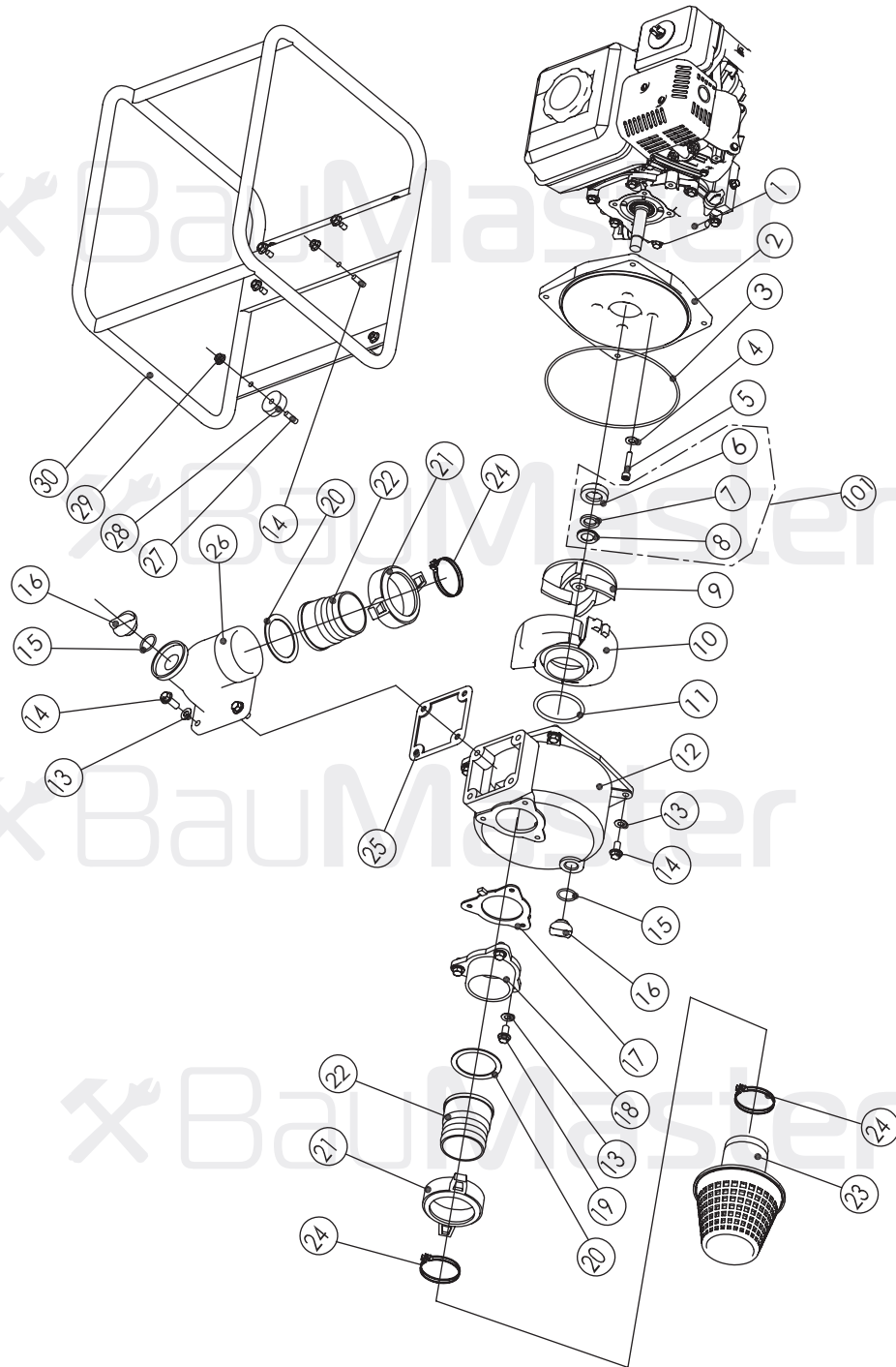

NO.	DESCRIPTION
1	ENGINE
2	PUMP BODY
3	"O" SEAL
4	WASHER
5	HEXAGON SCREWS
6	CASING WEAR RING
7	IMPELLER WEAR RING
8	IMPELLER SEALS
9	IMPELLER WITH KEY
10	SPIRAL CASE
11	"O" SEAL
12	PUMP COVER
13	PACKING8
14	FLANGE BOLT
15	"O" SEAL
16	PLUG
17	NON-RETURN VALVE
18	FLUME
19	FLANGE BOLT
20	SEAL PACKING
21	JOINT
22	HEAD
23	STRAINER
24	TABE CLIP
25	SEAL PACKING
26	ELBOW DRAFT TUBE
27	FLANGE BOLT
28	FRAME RUBBER
29	NUT M8
30	FRAME
101	MECHANICAL SEAL ASSEMBLY(6+7+8)

BM20111216

ЭЛЕКТРОДВИГАТЕЛЬ ДЛЯ ВР-8755Х

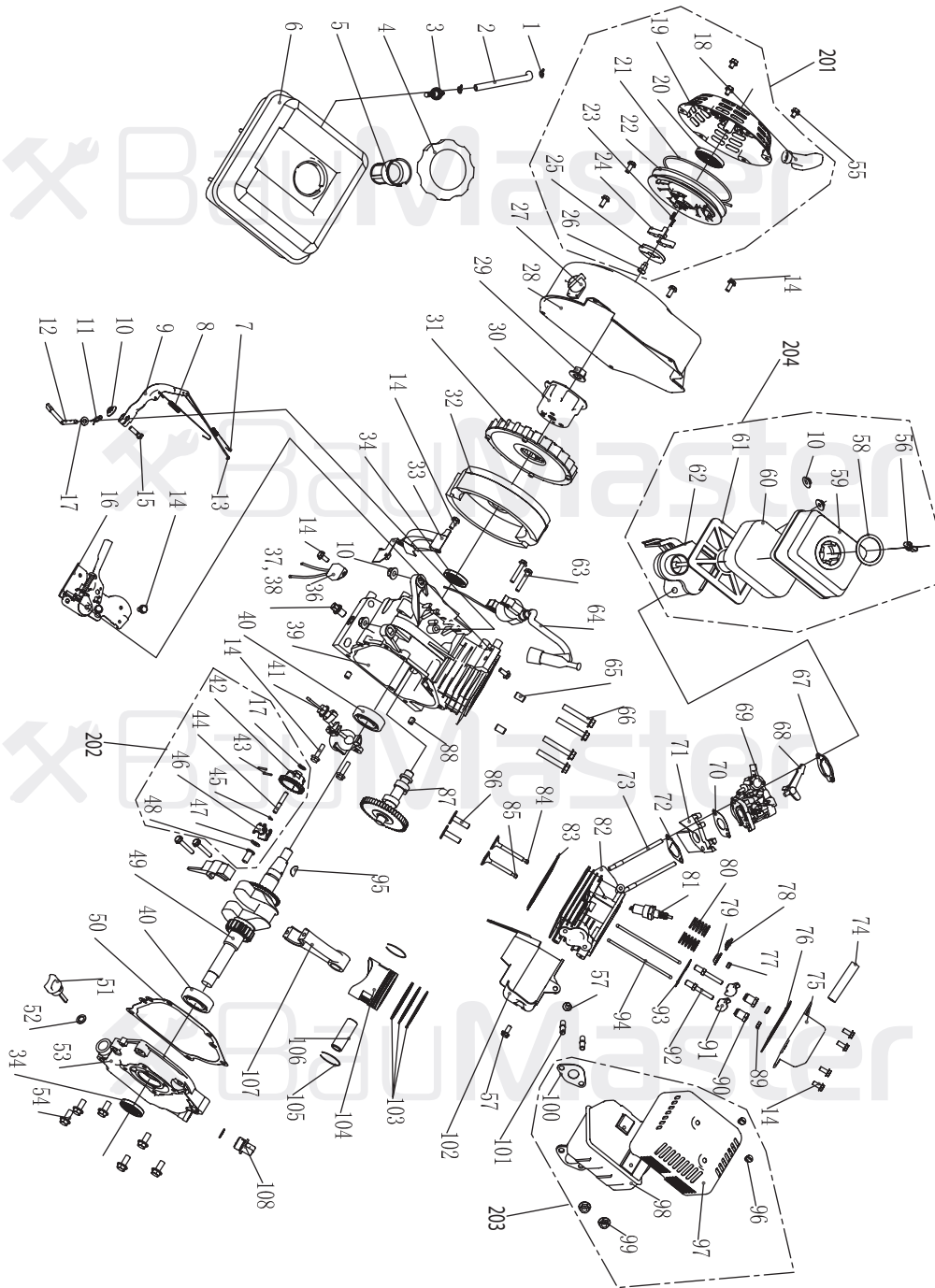

No.	DESCRIPTION	No.	DESCRIPTION	No.	DESCRIPTION
1	CLIP	40	RADIAL BALL BEARING 6205	79	EXHAUST VALVE SPRING RETAINER
2	TUBE	41	OIL LEVEL SWITCH ASSY	80	VALVE SPRING
3	FUEL TANK JOINT	42	GOVERNOR WEIGHT HOLDER	81	SPARK PLUG
4	FUEL FILLER CAP COMP	43	GOVERNOR WEIGHT PIN	82	CYLINDER HEAD COMP
5	OIL FILTER COMP	44	GOVERNOR SHAFT	83	CYLINDER HEAD GASKET
6	FUEL TANK COMP	45	GOVERNOR HOLDER CLIP	84	INTAKE VALVE
7	THROTTLE RETURN SPRING	46	GOVERNOR WEIGHT	85	EXHAUST VALVE
8	GOVERNOR SPRING	47	GOVERNOR SHAFT WASHER	86	VALVE LIFTER
9	GOVERNOR ARM	48	GOVERNOR COVER	87	CAMSHAFT ASSEMBLY
10	NUT	49	CRANKSHAFT COMP	88	DOWEL PIN
11	LOCK PIN	50	CASE OVER PACKING	89	PIVOT ADJUSTING NUT
12	GOVERNOR ARM SHAFT	51	OIL FILLER CAP ASSEMBLY	90	ROCKER ARM PIVOT
13	GOVERNOR ROD	52	OIL FILLER CAP PACKING	91	VALVE ROCKER ARM
14	FLANGE BOLT	53	CRANKCASE COVER	92	PIVOT BOLT
15	GOVERNOR ARM BOLT	54	FLANGE BOLT	93	PUSH ROD GUIDE PLATE
16	CONTROL ASSEMBLY	55	FLANGE BOLT	94	PUSH ROD
17	GOVERNOR WASHER	56	AIR CLEANER COVER NUT	95	KEY
18	RECOIL STARTER KNOB	58	AIR CLEANER CAP PACKING	96	SCREW
19	RECOIL STARTER COMP	59	AIR CLEANER COVER	97	MUFFLER PROTECTOR
20	RECOIL STARTER SPRING	60	AIR CLEANER ELEMENT	98	MUFFLER COMP
21	RECOIL STARTER ROPE	61	AIR CLEANER GRID	99	NUT
22	RECOIL STARTER REEL	62	AIR CLEANER ELBOW COMP	100	MUFFLER PACKING
23	RETURN SPRING	63	FLANGE BOLT	101	STUD BOLT
24	STARTER RATCHET	64	IGNITOR	102	SHROUD COMP
25	RATCHET GUIDE	65	DOWEL PIN	103	FIRST RING SET
26	SETTING SCREW	66	FLANGE BOLT		SECOND RING SET
27	SWITCH	67	CARBURETOR WASHER		RING COMP
28	FAN COVER COMP	68	CHOKE LEVEL COMP	104	PISTON
29	NUT	69	CARBURETOR ASSEMBLY	105	PISTON PIN CLIP
30	START HUB	70	CARBURETOR PACKING	106	PISTON PIN
31	COOLING FAN	71	CARBURETOR INSULATOR	107	CONNECTING ROD COMP
32	FLY WHEEL	72	INSULATOR PACKING	108	OIL FILLER CAP
33	SIDE PLATE & DIODE BASE COMP	73	STUD BOLT	201	RECOIL STARTER ASSEMBLY(18+19...+26)
34	OIL SEAL	74	BREATHER TUBE	202	GOVERNOR WEIGHT ASSEMBLY(17+42+43...+48)
36	DIODE COMP	75	HEAD OVERCOMP	203	MUFFLER ASSEMBLY(96+97...+100)
37	DRAIN PLUG BOLT	76	HEAD OVERPACKING	204	AIR CLEANER ASSEMBLY(10+56+58...+62)
38	DRAIN BOLT WASHER	77	VALVE ROTATOR		
39	CRANKCASE	78	INTAKE VALVE SPRING RETAINER		