

### БТ-8944М БТ-8953М

NO.	DESCRIPTION	NO.	DESCRIPTION
1	CLUTCH CASE ASSY	19	SCREW M6*30 (BUILT-UP)
2	BELT	20	SCREW M6*20 (BUILT-UP)
3	LIFTING RING(BIG)	21	SCREW M5*14 (BUILT-UP)
4	LIFTING RING(SMALL)	22	SCREW M5*20 (BUILT-UP)
5	SWITCH ASSY	23	NUT M5
6	LEFT HANDLE	24	SCREW M6*25 (BUILT-UP)
7	HANDLE SCREW	25	SCREW M5*25(BUILT-UP)
8	SPRING	26	HANDLE HOLDER(2)
9	HANDLE HOLDER(1)	27	HANDLE HOLDER(3)
10	SHAFT PIPE	28	HANDLE HOLDER(4)
11	PROTECTOR HOLDER	29	CUTTING KNIFE
12	GEAR BOX ASSY	30	SCREW ST4.2*8
13	3T BLADE	31	SWITCH ALU PIPE
14	PROTECTOR	32	LEFT HANDLE ALU PIPE
15	PROTECTOR SEAT		
16	TRANSMISSION SHAFT		
17	BEARING		
18	NYLON CUTTER		

EN-UK20200924

## БЕНЗОДВИГАТЕЛЬ ДЛЯ БТ-8944М БТ-8953М

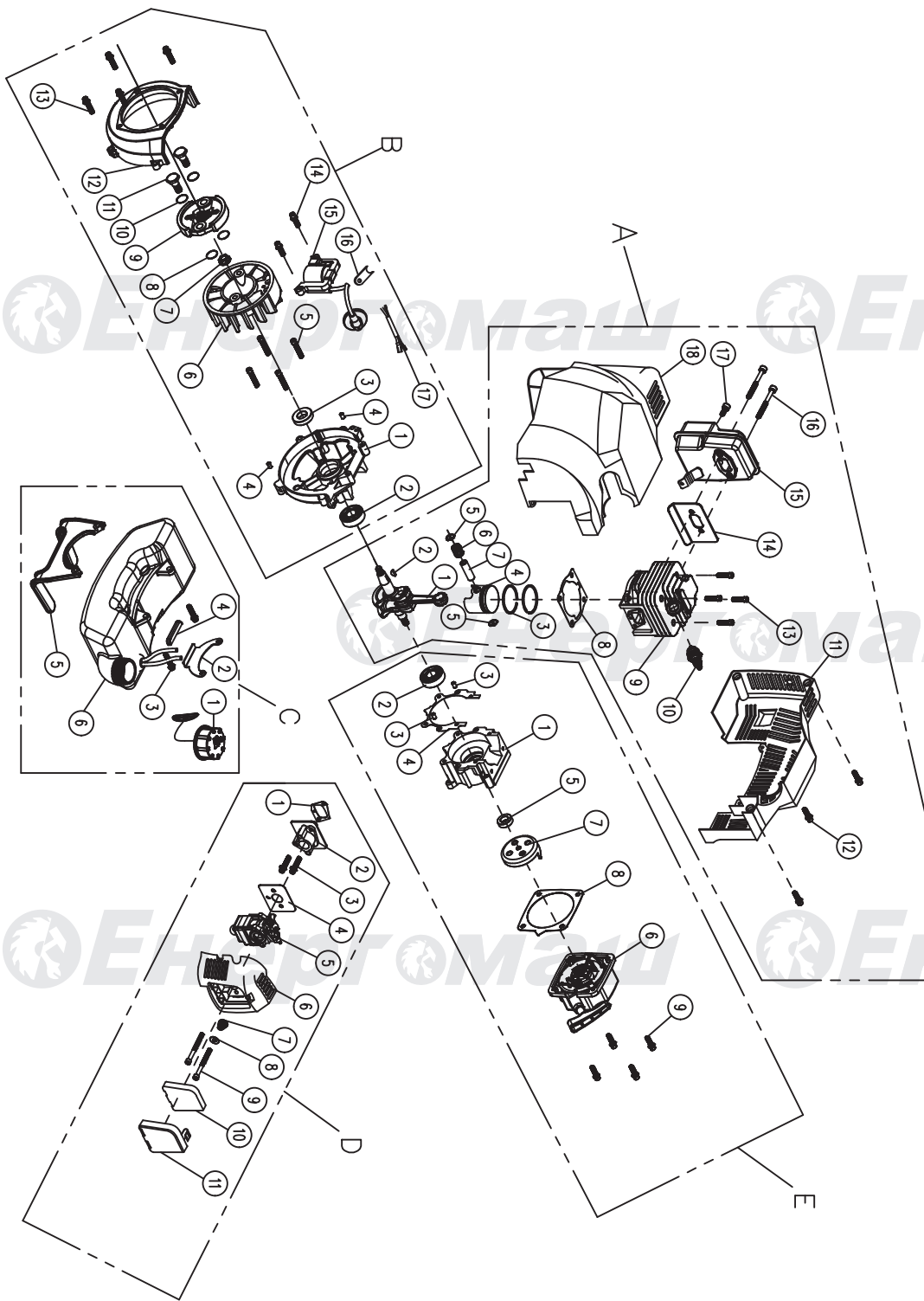

### Area A

NO.	DESCRIPTION
1	CRANKSHAFT
2	PIN 3*5*13
3	PISTON RING
4	PISTON
5	PISTON PIN RING
6	BEARING
7	PISTON PIN
8	GASKET
9	CYLINDER
10	SPARK PLUG BM6A
11	BACK COVER
12	SCREW
13	SCREW M6*20
14	GASKET
15	MUFFLER
16	SCREW M6*55
17	SCREW M5*12
18	FRONT COVER

### Area B

NO.	DESCRIPTION
1	CRANKSHAFT CASE(LEFT)
2	BEARING 6202
3	OIL SEAL15*30*7
4	PIN Ø5×10
5	SCREW M5*35
6	FLYING WHEEL
7	SCREW M8*1
8	GASKET 8
9	CLUTCH ASSY
10	GASKET 10
11	SCREW M8*9.8*24
12	SIDE COVER
13	SCREW M5*25
14	SCREW M5*20
15	COIL
16	COIL WIRE RUBBER
17	SHUT-DOWN WIRE

### Area C

NO.	DESCRIPTION
1	TANK LID ASSY
2	TANK HOLDER
3	SCREW M5*20
4	TANK HOLDER SHOCK REDUCER
5	TANK PROTECTOR
6	TANK ASSY

### Area D

NO.	DESCRIPTION
1	GASKET
2	INTAKE-TUBE
3	SCREW M5*30
4	GASKET
5	CARBURETOR
6	CARBURETOR STANDER
7	SPRING
8	GASKET 5
9	SCREW M5*55
10	SPONGE
11	AIR FILTER COVER

### Area E

NO.	DESCRIPTION
1	CRANKSHAFT CASE (RIGHT)
2	BEARING 6202
3	PINØ5×10
4	GASKET
5	OIL SEAL 12*22*7
6	STARTER (EASY)
7	DRIVE PLATE(EASY)
8	STARTER GASKET
9	SCREW M5*20

EN-UK20210907