

WE-2400

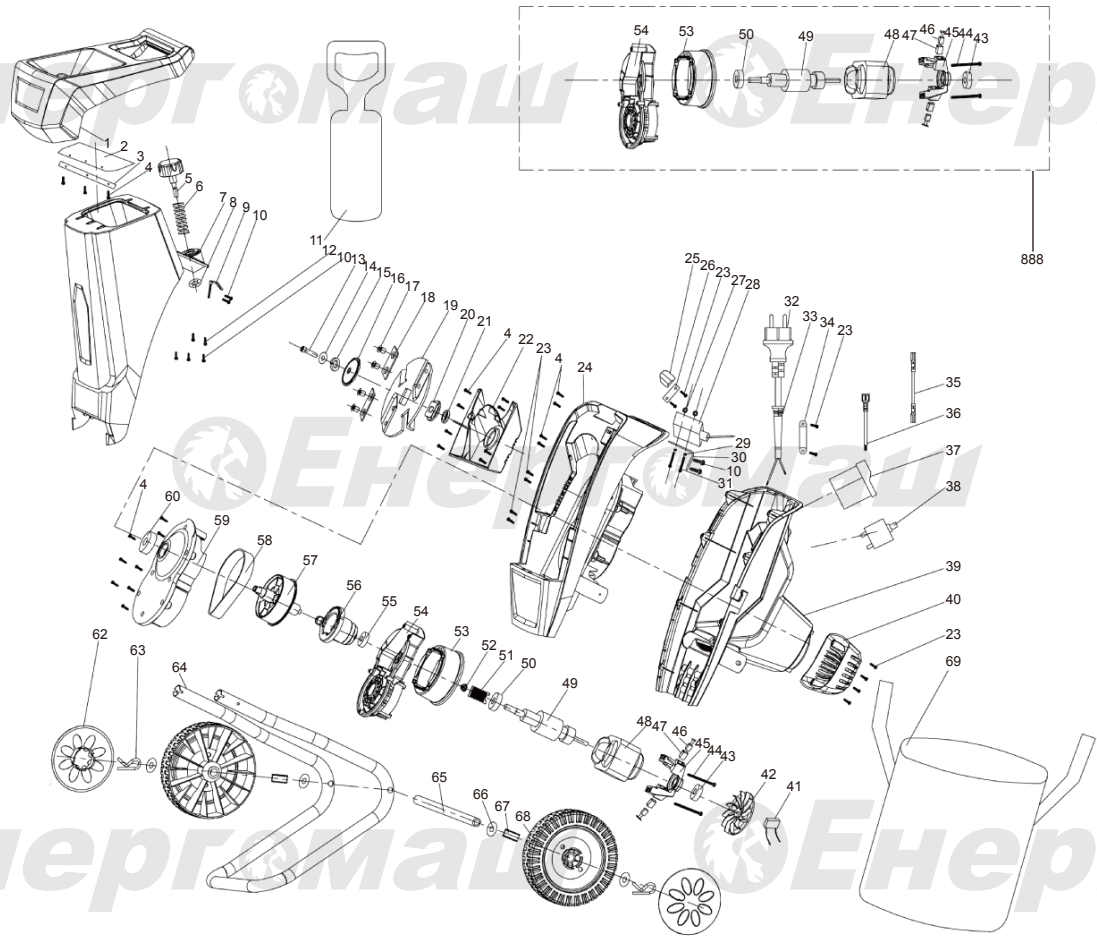

NO.	DESCRIPTION	NO.	DESCRIPTION
1	FEED HOPPER	34	CABLE CLAMP
2	SPLASH GUARD	35	CONNECTING LINE1
3	MOULDING	36	CONNECTING LINE2
4	SCREW	37	MAGNETIC SWITCH
5	KNOB	38	OVERCURRENT PROTECTION
6	SPRING	39	MOTOR CASING
7	UP HOUSING	40	MOTOR HOUSING COVER
8	RAND	41	CAPACITANCE
9	SWITCH PIN	42	FAN
10	SCREW	43	BEARING
11	CLEAR MATERIAL ROD	44	SCREW
12	"H" TYPE SCREW	45	MOTOR STENT (BACK)
13	INNER HEXAGON SCREW	46	CARBON BRUSH
14	FLAT GASKET	48	STATOR
15	SPRING WASHER 1	49	ROTOR
16	BRIQUETTING	50	BEARING
17	SCREW	51	SMALLBELT WHEEL
18	BLADE	52	
19	CUTTER	53	WIND SHIELD
20	TRANSMISSION PIECE	54	GEARBOX COVER
21	AXIS GUIDE	55	BEARING
22	BLOCK BOARD	56	ECCENTRIC WHEEL
23	SCREW	57	BIG BELT WHEE
24	DOWN HOUSING	58	BELT
25	HOLD-DOWN NUT	59	GEARBOX COVER
26	NUT FIXED BOARD	60	BEARING
27	HEXNUT	62	WHEEL COVER
28	SWITCH	64	SUPPORTING TUBE
29	SPRING WASHER 1	65	CONNECTING ROD
30	SWITCH FIXED BOARD	66	GASKET 2
31	SCREW	67	AXLE SETS
32	POWER LINE	68	WHEEL
33	CABLE SHEATH	69	RUBBISH BAG