

Sturm!

POWER • GAS • HAND • TOOLS

BS8511U

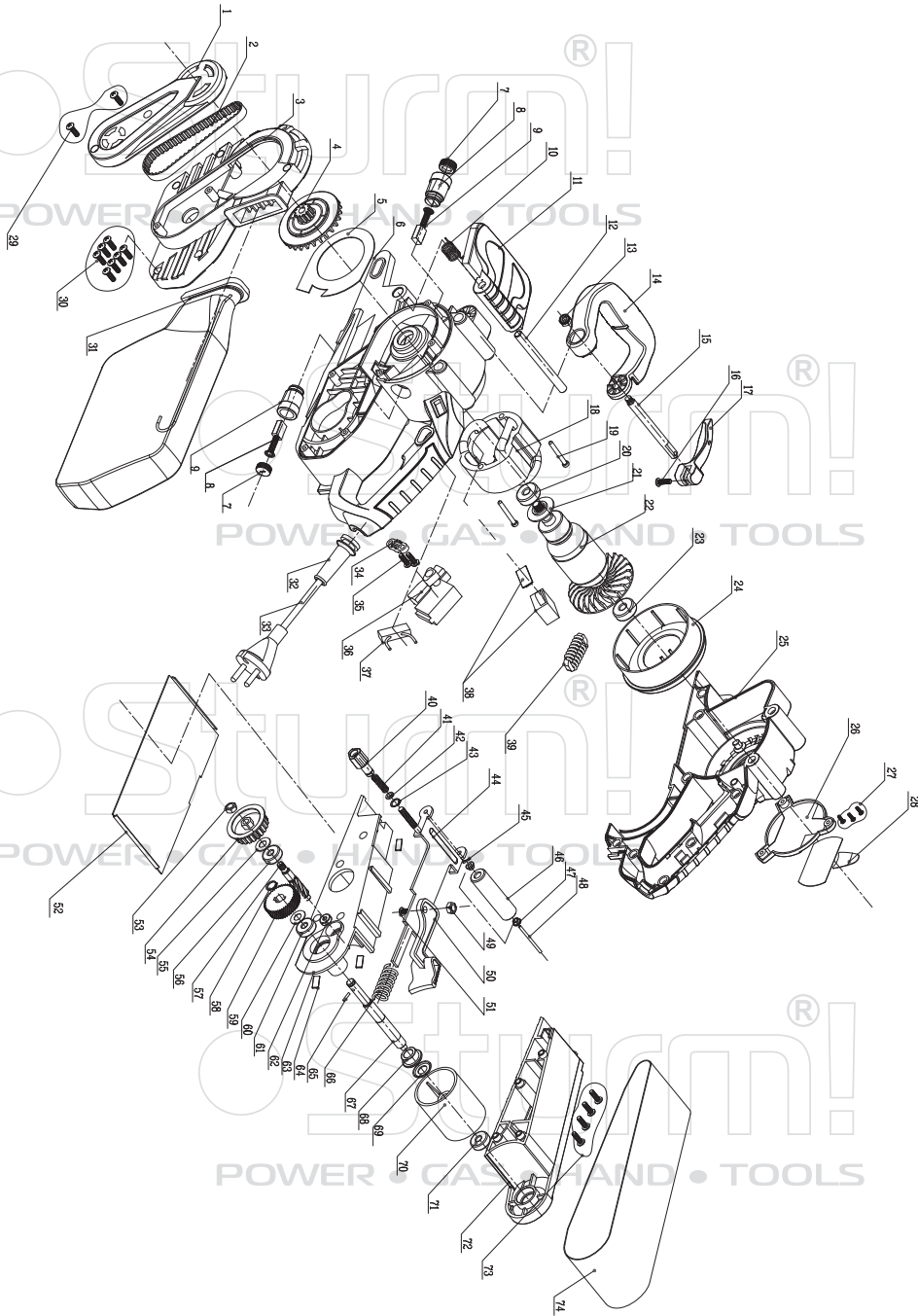

NO.	DESCRIPTION	NO.	DESCRIPTION
1	BELT COVER	38	DECORATIVE COVER & SPEED CONTROL SWITCH
2	SYNCHRONOUS BELT	39	INDUCTOR
3	MIDDLE COVER	40	ADJUST KNOB
4	SMALL PULLEY	41	SMALL SPRING
5	WIND CIRCLE	42	WASHER Ø13XØ6X1
6	LEFT HOUSING	43	CHECK RING
7	BRUSH COVER GRIP	44	FRONT-WHEEL FRAME
8	BRUSH HOLDER	45	FIXED SALES
9	BRUSH	46	FRONT WHEEL
10	TORSION SPRING	47	NEEDLE BEARING HK0609
11	ACTIVITIES OF THE SHAFT PLATE	48	FRAME AXIS
12	AXIS OF ROTATION	49	Ø6 WASHER
13	NUT	50	FRONT-WHEEL FRAME WRENCH
14	FRONT HANDLE	51	Ø6 RIVET
15	SCREW M6	52	IRON BOTTOM
16	SCREW ST4.2X16	53	NUT M6
17	FORMER HANDLE WRENCH	54	LARGE PULLEY
18	STATOR	55	WASHER Ø8
19	SCREW ST5X50	56	BEARING 627RS
20	BALL BEARING 608RS	57	SMALL GEAR SHAFT
21	INSULATION SPACER	58	PLAIN WASHER
22	ROTOR	59	BIG GEAR
23	BALL BEARING 608RS	60	WASHER Ø8
24	INTRODUCTION SETS OF WIND	61	BEARING 608RS
25	RIGHT HOUSING	62	BALL BEARING 606
26	NAMEPLATE DECORATIVE COVER	63	ALUMINUM BASE
27	SCREW ST2.9X12	64	CERAMIC SHEET
28	NAMEPLATE	65	CYLINDRICAL PIN Ø3X11
29	SCREW ST4.2X16	66	SPRING
30	SCREW ST4.2X16	67	REAR AXLE
31	DUST ADAPTER	68	COPPER SETS
32	CABLE GUARD	69	BOWL-TYPE GASKET
33	CABLE	70	REAR WHEEL
34	CABLE PRESS BOARD	71	BALL BEARING 626
35	SCREW ST4.2X16	72	PLASTIC BRACKET
36	SWITCH	73	SCREW ST4.2X40
37	CAPACITOR0.22UF	74	SANDING BELT