

МБ-1530А

NO.	DESCRIPTION
1	ENGINE FIXED BASE
2	RUBBER BASE
3	HANDLE
4	CLUTCH
5	UP GEAR BOX
6	BEARING R10
7	STEEL RING
8	PIN
9	48 TEETH GEAR
10	44 TEETH GEAR
11	10 TEEH SHAFT GEAR
12	PAPER WASHER
13	DOWN GEAR BOX
14	SCREW M6X30
15	SPINDLE
16	BEARING 6004Z
17	SCREW M6X50
18	7 TEETH SHAFT GEAR
19	SWITCH
20	BRACKET
21	RUBBER COVER

EN-BM20170623

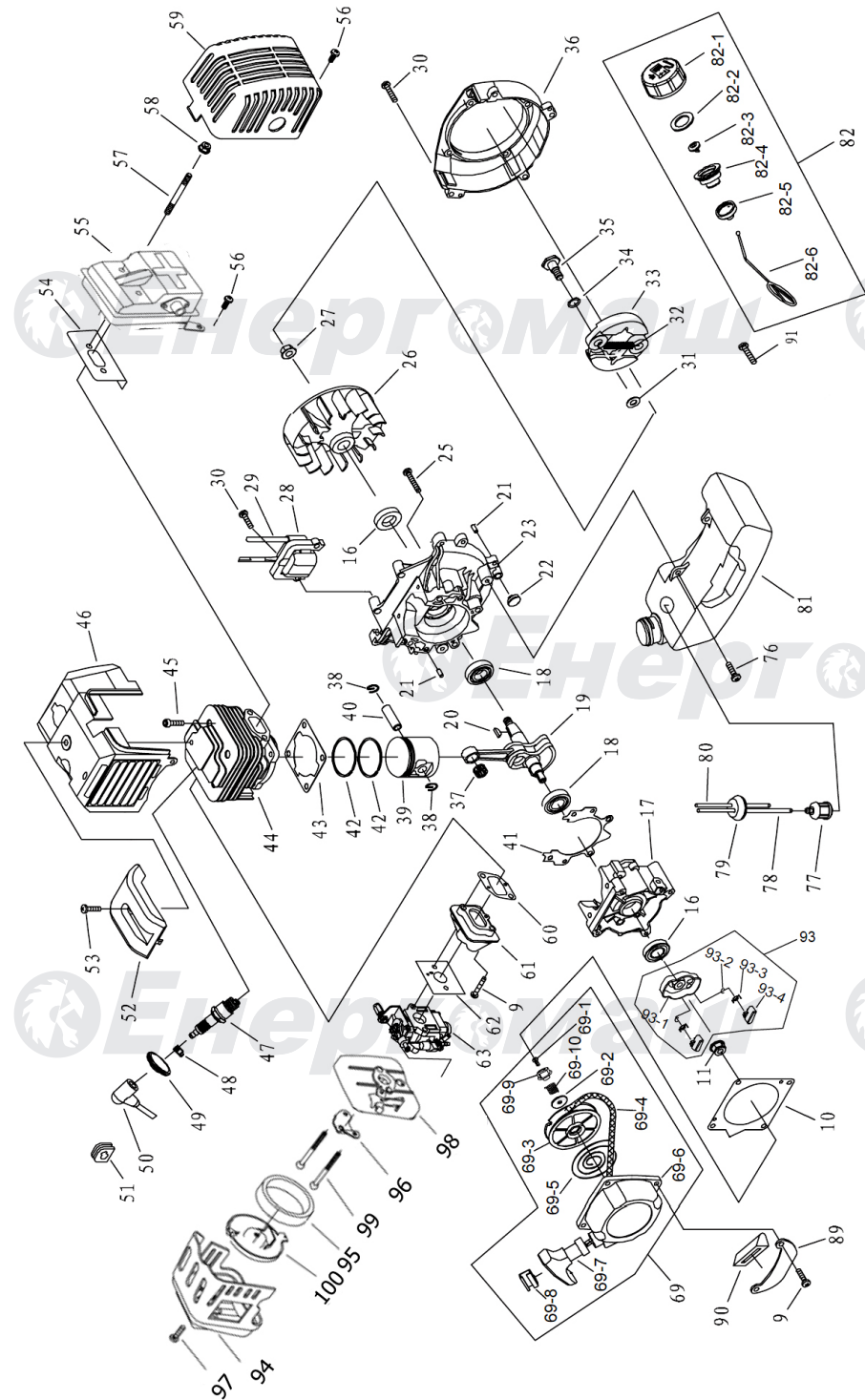

ENGINE FOR M5-1530A

NO.	DESCRIPTION	NO.	DESCRIPTION	NO.	DESCRIPTION
9	SCREW M5X20	44	CYLINDER	69-10	EASY START COIL SPRING
10	GASKET	45	SCREW	76	SCREW M5X16
11	NUT	46	GUIDE COVER ASSY	77	CLEANER COVER
16	OIL SEAL	47	SPARK PLUG	78	OUTLET FUEL PIPE
17	CRANK CASE	48	SPRING	79	PLUG
18	BEARING 6202	49	PLUG COVER	80	INLET FUEL PIPE
19	CRANKSHAFT	50	PLUG CAP	81	FUEL TANK
20	KEY	51	PLUG	82	LID ASSY
21	PIN	52	UPPER COVER	82-1	FUEL TANK LID
22	RUBBER WASHER	53	SCREW	82-2	GASKET
23	CRANK CASE	54	GASKET	82-3	INLET
25	SCREW M5X30	55	MUFFLER	82-4	INSIDE COVER
26	MAGNETO ROTOR COMP	56	SCREW	82-5	LID
27	NUT	57	BOLT	82-6	CHAIN
28	IGNITION COLL COMP	58	NUT	89	STAND
29	CORD COMP	59	MUFFLER COVER	90	RUBBER COVER
30	BOLT M5X20	60	GASKET	91	SCREW M5X20
31	WASHER	61	ADMITTING PIPE	93	STARTER PULLEY ASSY
32	SPRING	62	GASKET	93-1	STARTER REEL
33	EXPANDER	63	CARBURETOR	93-2	STOP RING
34	WASHER	69	STARTER	93-3	STARTER PAWL SPRING
35	SCREW PIN	69-1	SCREW	93-4	STARTER PAWL
36	FAN COVER	69-2	WASHER	94	AIRFILTER COVER
37	BEARING 10X13X16	69-3	START POPE REEL	95	AIR CLEANER
38	RING	69-4	POPE	96	AIRFILTER COVER SEAT
39	PISTON	69-5	RECOIL SPRING	97	SCREW
40	PISTON PIN	69-6	START COVER ASSY	98	CHOKE SEAT ASSY
41	GASKET	69-7	START HANDLE	99	SCREW
42	PISTON RING	69-8	RING	100	CIRCULAR COVER
43	GASKET	69-9	START RATCHET		

EN-BM20170623