

MB-92232

NO.	DESCRIPTION
1	CAP
2	DETERGENT TANK
3	WATER INLET CONNECTOR&FILTER
4	BACK HOUSING
5	WHEEL
6A	MOTOR&PUMP ASSY
7	WHEEL COVER
8	GUN HOLDER
9	CABLE JACKET
10	CABLE PRESS PLATE
11	SCREW
12	POWER CABLE
13	SWITCH KNOB
14	FRONT HOUSING
15	PRESSURE HOSE
16	CLEANING PIN
17	BUTTON
18	FRONT DECORATIVE PLATE
19	ADJUSTABLE NOZZLE
20	GUN
21	HANDLE SLEEVE
22	HANDLE
23	SCREW
24	PRESSURE WASHER CLIP
25	HOSE REEL
26	HOSE REEL BRACKET
27	HOSE REEL AXIS
28	CAP NUT
29	ROCKING HANDLE
30	SCREW
31	ROCKING HANDLE SLEEVE
32	WARNING LABEL
33	RATING LABEL
34	POWER CABLE HOOK
35	ACCESSORIES HOLDER
36	DETERGENT TUBE

UK-EN20170927-01

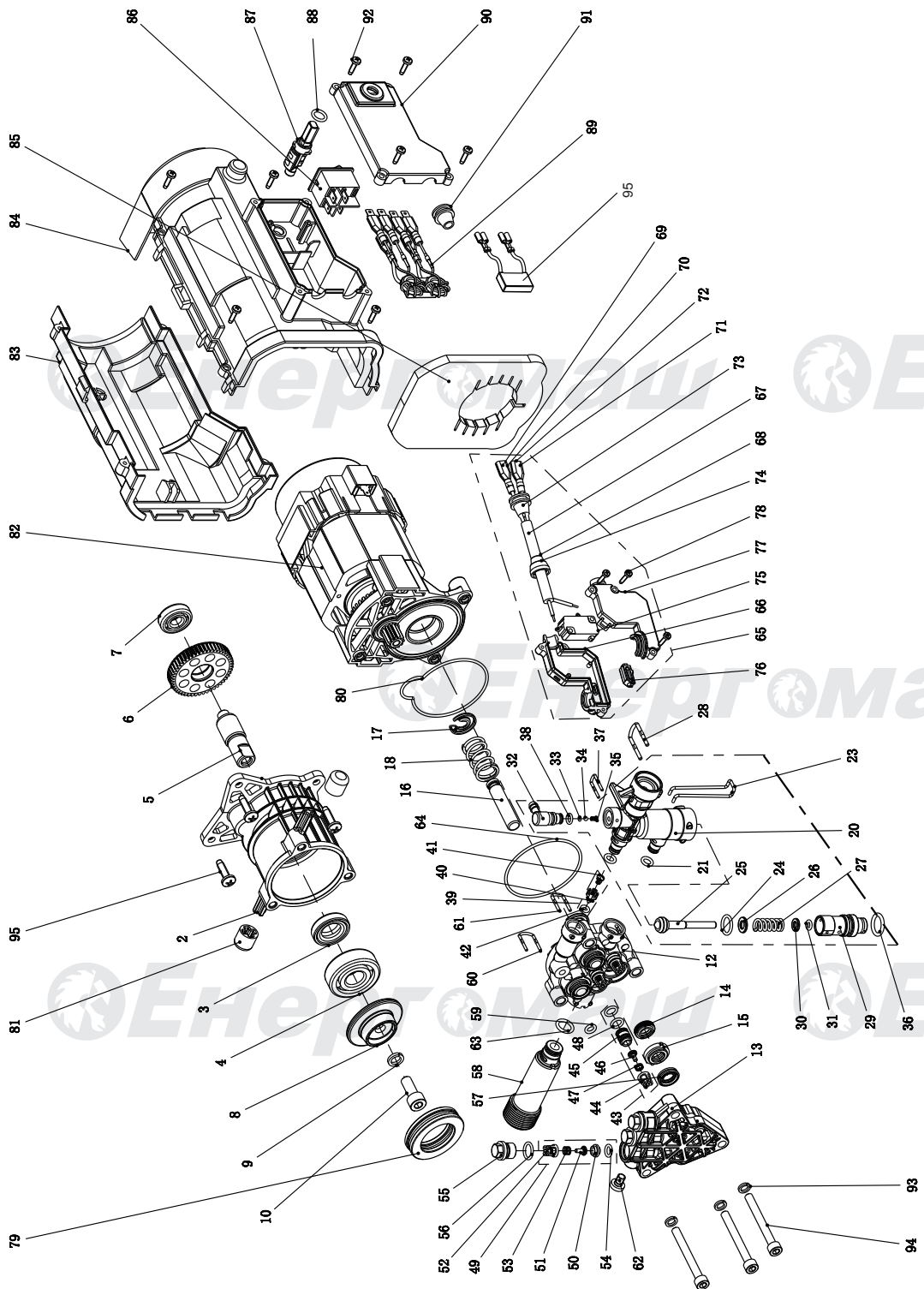

PUMP FOR MB-92202 MB-92232

NO.	DESCRIPTION	NO.	DESCRIPTION
2	OIL CYLINDER	51	CHECKING VALVE CORE
3	OIL SEAL 30X17X7	52	CHECKING VALVE BRACKET
4	BEARING 6302Z	53	CHECKING VALVE SPRING
5	GEAR SHAFT	54	O RING 6X1.8
6	BIG GEAR	55	CHECKING VALVE CAP
7	BEARING 629-2Z	56	O RING 9.5X1.8
8	SWASH PLATE	57	OIL SEAL 10X16X4
9	GASKET 8	58	INLET HOSE
10	BLOT M8X20	59	O RING 5.5X2
12	PUMP BODY	60	U PIN
13	PUMP COVER	61	U PIN
14	PLUNGER OIL SEAL 10X16X4	62	BOLT M6X8
15	OIL SEAL BRACKET	63	O RING 10X2.2
16	PLUNGER	64	O RING 58X2
17	PLUNGER CHUCK	65	ON-OFF SWITCH ASSY
18	PLUNGER SPRING	66	SWITCH-DOWN COVER
20	OUTLET HOSE	67	SWITCH WIRE ASSY
21	O RING 5.5X2	68	SWITCH WIRE
23	BAYONET LOCK	69	FEMALE TERMINAL
24	O RING 12X2	70	COVER FOR FEMALE TERMINAL
A25	RELIEF VALVE CORE	71	MALE TERMINAL
26	LIMIT RING	72	COVER FOR MALE TERMINAL
27	RELIEF VALVE SPRING	73	COVER FOR OUTLET WIRE
28	U PIN	74	COVER FOR SWITCH
29	RELIEF VALVE CAP	75	ON-OFF SWITCH(WELDED)
30	RELIEF VALVE GASKET	76	ON-OFF SWITCH PUSH ROD
31	O RING 4.5X1	77	SWITCH- UP COVER
32	SIPHON ELBOW	78	BOLT ST2.9X13
33	O RING	79	BEARING 51106
34	STAINLESS STEEL BALL	80	SEAL RING
35	SIPHON SPRING	81	DAMPING RING
36	O RING 12X2.5	82	MOTOR
37	U PIN	83	FAN COVER DOWN
38	O RING	84	FAN COVER UP
39	BACK PRESSURE VALVE ASSY	85	FAN COVER FILTER
40	BACK PRESSURE VALVE CORE	86	MAIN SWITCH
41	BACK PRESSURE VALVE SPRING	87	SWITCH DRIVING LEVER
42	O RING 3.5X1.9	88	O RING 8X2
43	INLET CHECKING VALVE ASSY	89	INDUCTANCE ASSY
44	CHECKING VALVE BRACKET	90	SWITCH COVER
45	INLET CHECKING VALVE SEAT	91	OUTLET WIRE COVER
46	CHECKING VALVE CORE	92	BOLT ST3.5 X13F
47	CHECKING VALVE SPRING	93	GASKET 6
48	O RING 6X1.8	94	BOLT M6X55
49	OUTLET CHECKING VALVE ASSY	95	CAPACITOR ASSY
50	CHECKING VALVE SEAT		