

GC-99502X

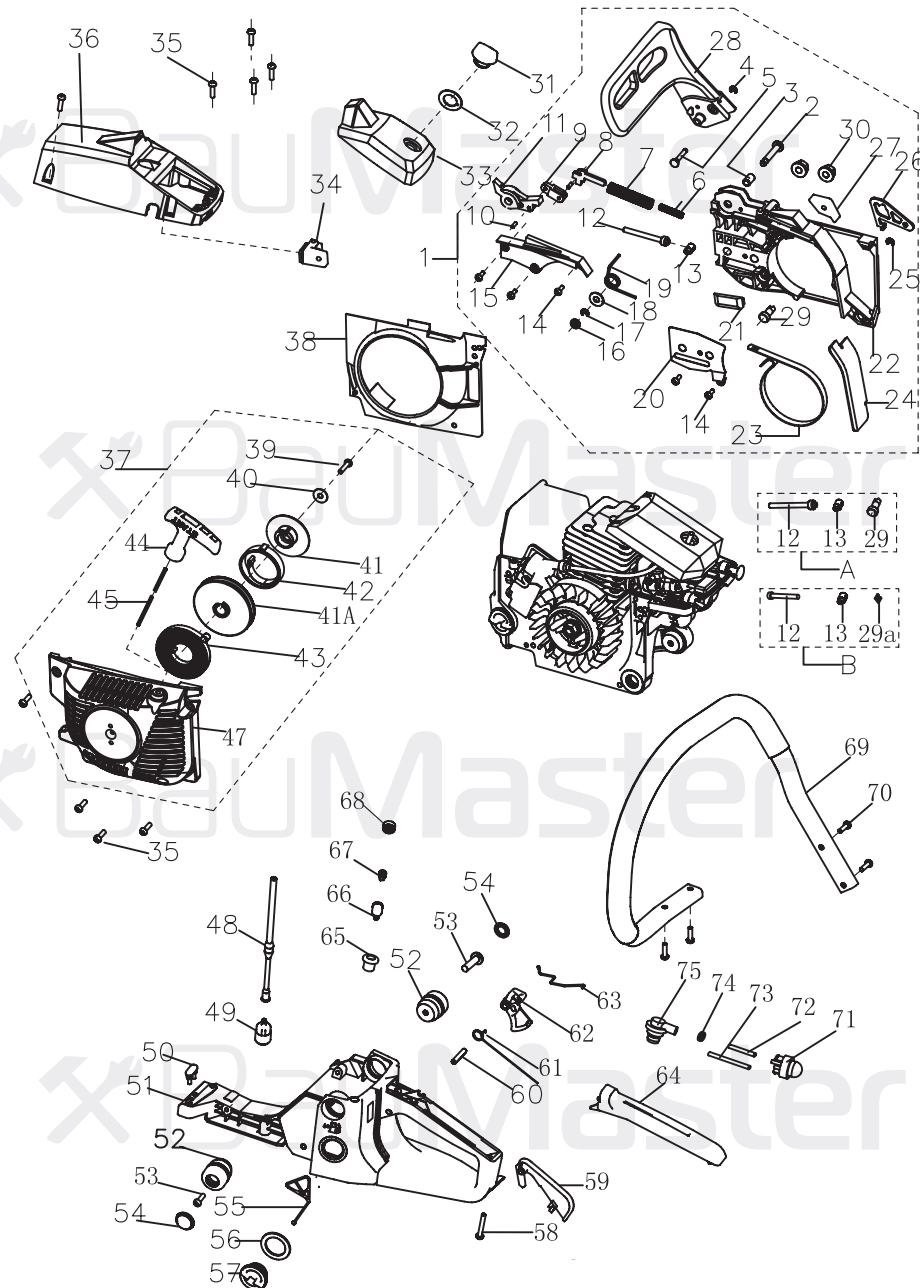

NO.	DESCRIPTION	NO.	DESCRIPTION
1	right cover assembly	39	tapping screw ST4.8x13
2	shield pin	40	washer 5
3	shield pin gland	41	start plate
4	ring 3	41a	rope coil plate
5	spacer pin	42	start coil-spring
6	secondary brake spring	43	return coil-spring
7	brake spring	44	start handle
8	brake control rod	45	start stretching wire
9	secondary pull-rod	47	start cover
10	pin 3x9	48	fuel tube
11	main level	49	petrol filter components
12	tightener screw	50	shock rubber
13	tension block	51	base
14	tapping screw ST4x8	52	shock rubber gland
15	brake spring cover plate	53	screw ST5X16
16	shock rubber washer	54	dust cover
17	shield ring 5	55	anti-drop plate
18	washer 6	56	packing washing 20X30X2
19	brake torsion rod spring	57	oil cover
20	tensioner cover plate	58	tapping screw ST4X25
21	chain guide dog	59	trigger control rack
22	right cover	60	pin6X30
23	brake strap	61	trigger torsion rod spring
24	dust shield	62	trigger
25	shield ring 4	63	throttle rod
26	spacing shield	64	handle cover
27	shock rubber cushioning	65	balancer oil tube
28	front damper	66	balancer body
29	tension gear	67	balancer rubber
29a	bounds block	68	balancer cover
30	nut M8	69	front handle assembly
31	air filter lock nut	70	tapping screw ST5X16
32	lock nut washer 15X26X1	71	primer bulb
33	air filter cover	72	back fuel tube
34	idle adjusting guide set	73	fuel pump tube
35	screw M5X16	74	tube clip
36	upper cover plate	75	oil nozzle
37	starter assembly		
38	bossing		

BM20110330-01

GC-99502X ENGINE

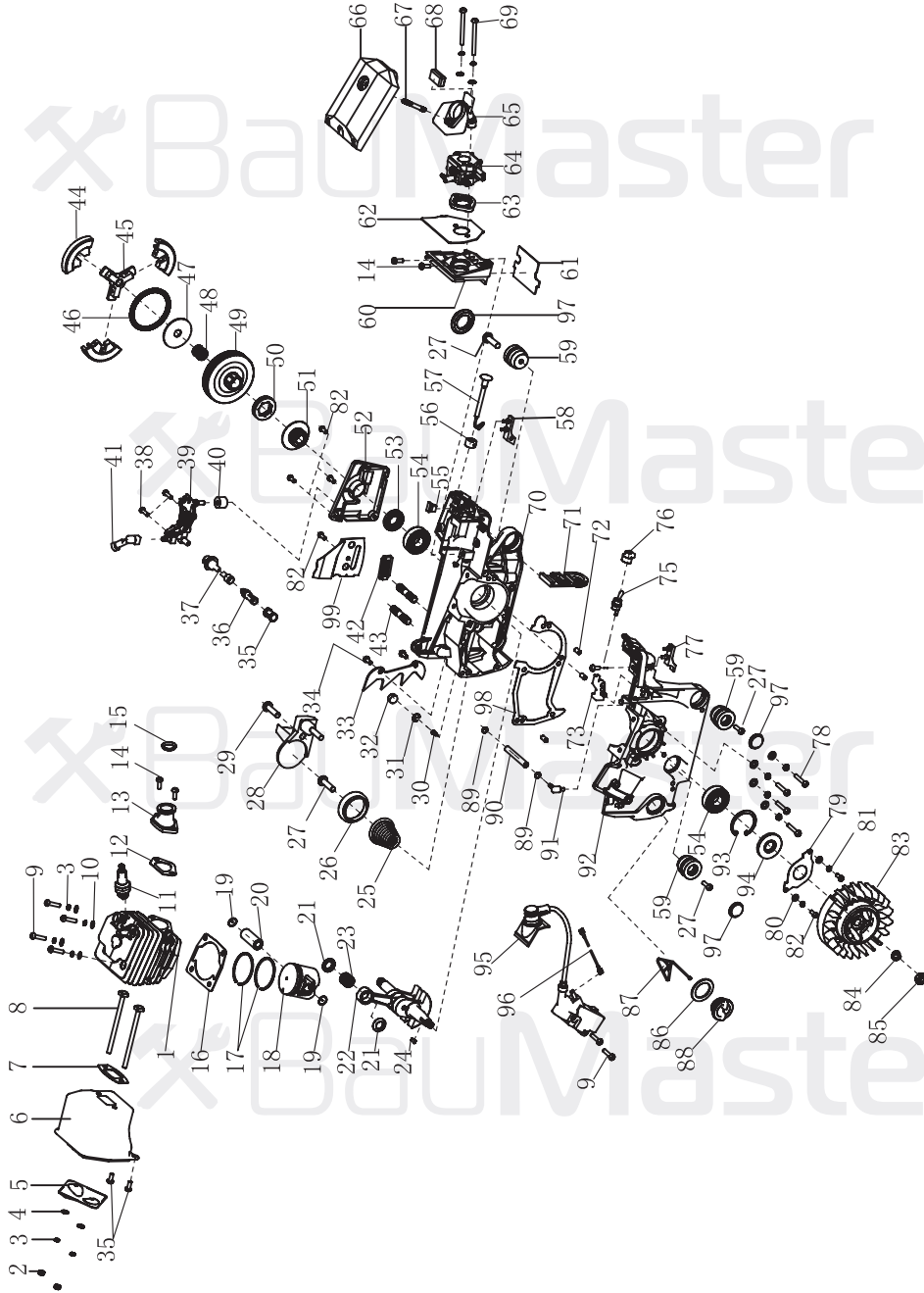

NO.	DESCRIPTION	NO.	DESCRIPTION
1	CYLINDER BODY	50	SPROCKET
2	NUT M5	51	TURBINE
3	WASHER 5	52	COVER PLATE
4	WASHER 5	53	OIL SEAL 15X28X4.5
5	SILENCER COVER PLATE	54	BEARING 6202 GRADE D 15X35X11
6	SILENCER BODY	55	SHOCK BLOCK 1
7	SILENCER SEALING PLATE	56	THROTTLE LEVER RETAINING BRACKET
8	MUFFLER CONNECTING SCREW	57	THROTTLE ROD
9	SCREW M5X20	58	RIGHT SHOCK BLOCK
10	WAHSER 5	59	CUSHION SOCKET
11	SPARK PLUG	60	AIR INTAKE SUPPORT
12	AIR INTAKE TUBE SEALING PLATE	61	BACKING BOART
13	AIR INTAKE TUBE	62	SEALING PLATE OF AIR INTAKE SUPPORT
14	SCREW M5X12	63	AIR INTAKE FLANGE
15	HOLD COIL	64	CARBURETOR
16	CYLINDER SEALING PLATE	65	AIR INTAKE SOCKET
17	PISTON RING	66	AIR FILTER
18	PISTION	67	DOUBLE-SCREW BOLT GM5-M5X30
19	PISTON PIN CIRCLIP	68	CUSHION OF AIR INTAKE SOCKET
20	PISTON PIN	69	NUT M5X50
21	NEEDLE BEARING RING	70	RIGHT CASE BODY
22	CRANKSHAFT CONNECTING BAR COMPONENTS	71	DUST PLATE
23	NEEDLE BEARING 11X15X12.5	72	PIN 5X10
24	SEMICIRCULAR KEY 3X3.5X10	73	SHOE BLOCK 2
25	CONICAL SPREADER SPRING	75	EXTINCTION SWITCH
26	CONICAL SPREADER BASE	76	EXTINCTION SWITCH SOCKET
27	TAPPING SCREW ST5X16	77	LEFT SHOCK BLOCK
28	CHAIN CATCHER	78	SCREW M5X25
29	SCREW M5X16	79	OIL SEAL DAMPER
30	AERATION JET	80	WASHER 4
31	AERATION JET CIRCLIP	81	WASHER 4
32	SPONGE TRANSITION BLOCK	82	SCREW M4X10
33	BUMPER SPIKES	83	FLYWHEEL
34	SCREW M5X10	84	WASHER 8
35	OIL FILTER SCREEN	85	NUT M8X1
36	OIL FILTER	86	PACKING WASHING 20X30X2
37	OIL TUBE	87	ANTI-DROP PLATE
38	SCREW M4X14	88	OIL COVER
39	OIL PUMP	89	SUCTION TUBE CIRCLIP
40	SPONGE TRANSITION COIL	90	SUCTION TUBE 2.5X7X105
41	NOZZLE	91	SUCTION JET
42	CHAIN GUIDE BLOCK	92	LEFT CASE BODY
43	DOUBLE-SCREW BOLT AYM8-M8X26-8.8	93	RING35
44	SHOE BLOCK	94	OIL SEAL 15X35X4.5
45	RETAINER	95	IGNITER
46	CLUTCH EXTENSION SPRING	96	EXTINCTION CONDUCTOR
47	CLUTCH ADJUSTING WASHER	97	DUST COVER
48	NEEDLE BEARING 12X15X14.5	98	CASE BODY SEALING PLATE
49	CLUTCH SHELL	99	DAMPER