

CA-97H20CM

NO.	DESCRIPTION
1	CAPACITY
2	HEAT SINKS 1
3	BELT
4	COVER SHELL
5	FAN COVER
6	SWITCH
7	FAN
8	POWER CABLE
9	CABLE FITTING
10	RELAY
11	BRIDGE RECTIFIER
12	HEAT SINKS 2
13	TRANSFORMER 1
14	PULSE TRANSFORMER
15	PCB1
16	POTENTIOMETER
17	POTENTIOMETER HAT
18	COPPER SHEET
19	CONNECTOR
20	BOTTOM SHELL
21	PCB2
22	IGBT
23	DIODE
24	HEAT PROTECTOR
25	HEAT SINKS 3
26	HEAT SINKS 4
27	TRANSFORMER 2
28	TRANSFORMER 3
998	RIGHT MAIN BOARD ASSEMBLY
999	LEFT MAIN BOARD ASSEMBLY

THE LEFT MAIN BOARD FOR CA-97M20CM

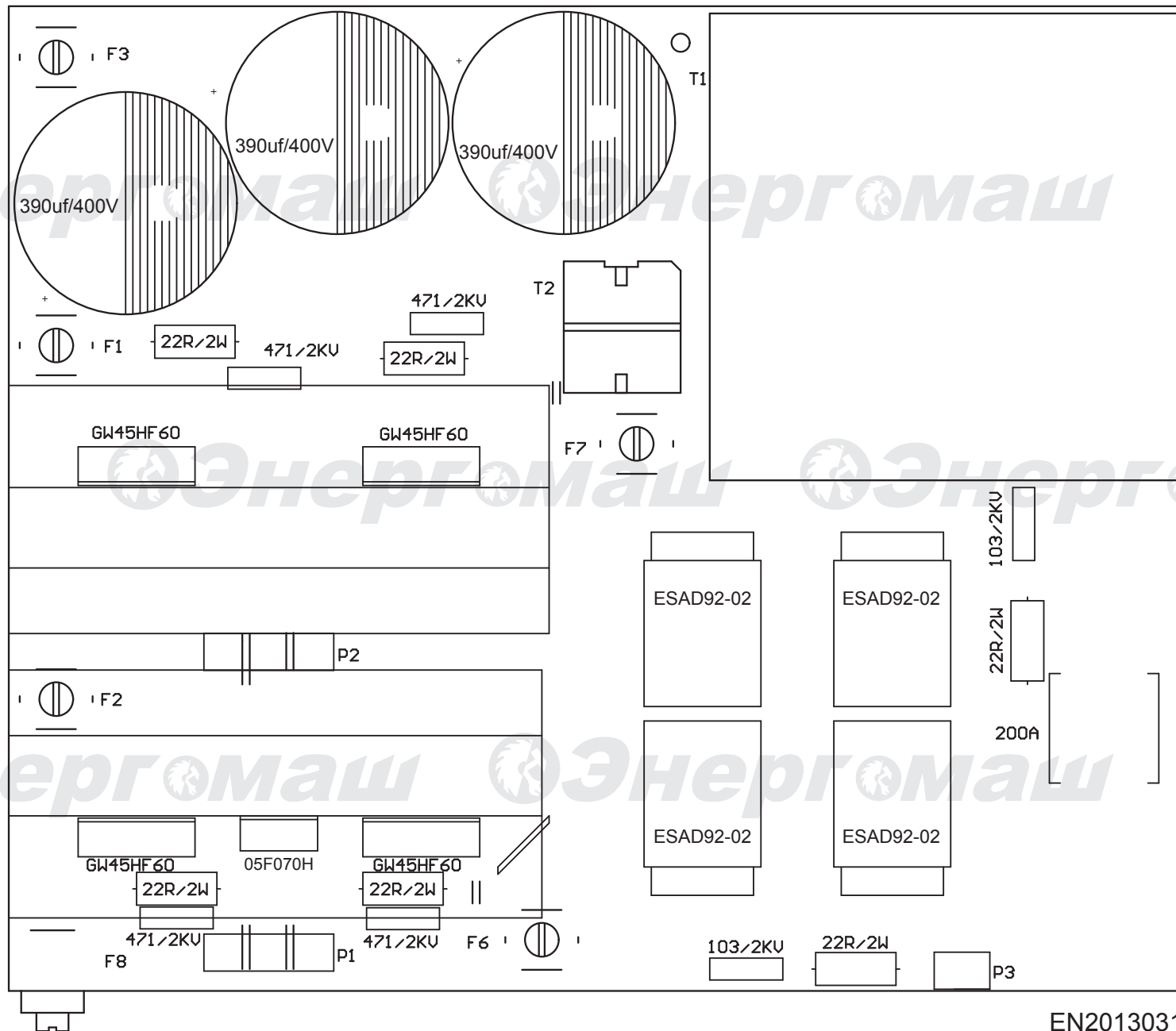

EN20130315

THE RIGHT MAIN BOARD FOR CA-97H20CM

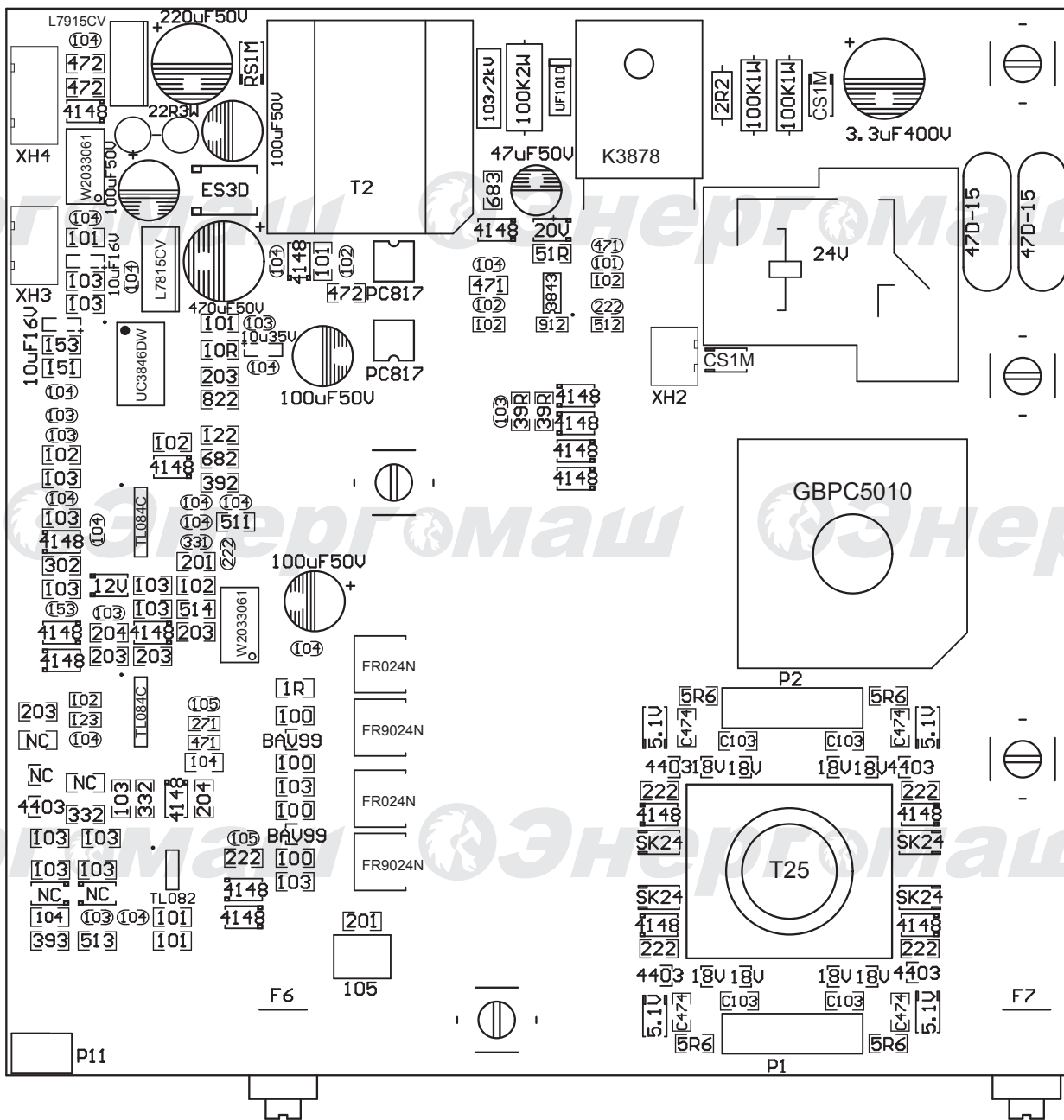

EN20130315