

# ПТС-99452Т

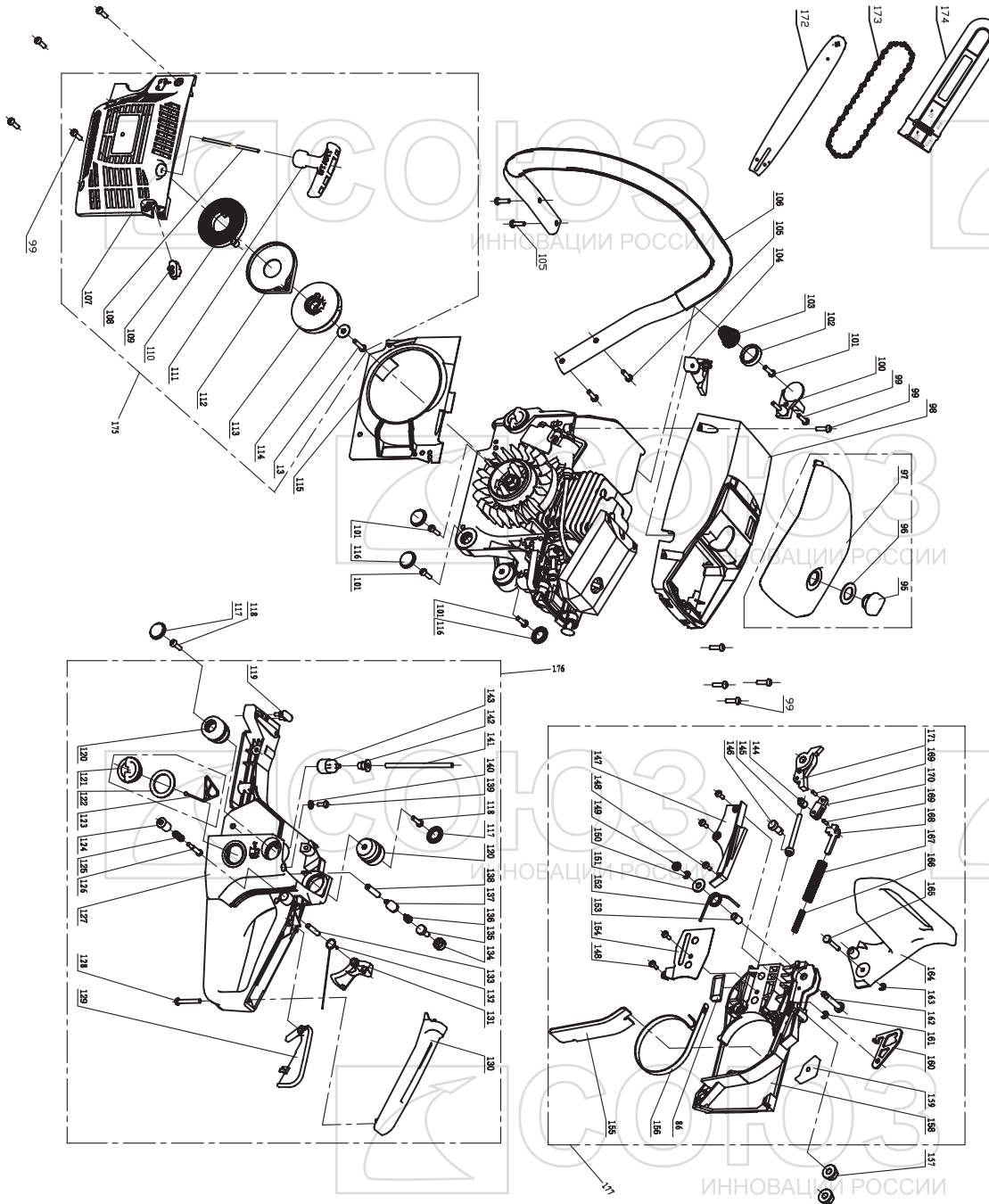

NO.	DESCRIPTION	NO.	DESCRIPTION	NO.	DESCRIPTION
95	AIR FILTER LOCK NUT	124	BUTTON	153	FRONT GUARD TUBE
96	LOCK NUT WASHER	125	BUTTON SPRING	154	TIGHTENER COVER
97	AIR FILTER COVER	126	SCREW	155	DUST SHIELD
98	UPPER COVER PLATE	127	BASE	156	BRAKE BELT
99	SCREW	128	TRIGGER CONTROLLER	157	NUT
100	CHAIN CATCHER	129	TRIGGER	158	RIGHT COVER
101	SCREW	130	HANDLE COVER	159	SHOCK RUBBER CUSHION
102	CONICAL SPRING BASE	131	TRIGGER TORSION ROD	160	CAM PLATE
103	CONICAL SPREADER SPRING	132	SPRING	161	SHIELD RING4
104	IDLE ADJUSTING GUIDE	133	PIN	162	FRONT GUARD PIN
105	SCREW	134	BALANCER COVER	163	SHIELD RING3
106	FRONT HANDLE ASSEMBLY	135	FILTER	164	FRONT GUARD
107	STARTER COVER	136	BALANCER RUBBER	165	POSITIONING PIN
108	START ROPE	137	BALANCER BODY	166	SECONDARY BRAKE SPRING
109	L H SHEATHING	138	BALANCER TUBE	167	BRAKE SPRING
110	COIL SPRING	139	SCREW	168	BRAKE CONTROL ROD
111	STARTING HANDLE	140	SEALING RUBBER	169	PIN 3X9
112	COIL SPRING SHELL	141	FUEL TUBE	170	SECONDARY PULL-ROD
113	STARTER WHEEL	142	FUEL TUBE BASE	171	MAIN PULL-ROD
114	BIG WASHER	143	FUEL FILTER COMPONENTS	172	BAR
115	COOLING-AIR MASK	144	TIGHTENER	173	CHAIN
116	DUST COVER	145	TIGHTENING SCREW	174	CHAIN COVER
117	DUST COVER	146	TIGHTENING GEAR	175	START ASSEMBLY
118	SCREW	147	BRAKE SPRING COVER	176	BASE ASSEMBLY
119	SHOCK RUBBER	148	SCREW	177	RIGHT COVER ASSEMBLY
120	ANTI-VIBRATION CUSHION C	149	SHOCK RUBBER WASHER		
121	FUEL CAP	150	SHIELD RINGS		
122	PACKING WASHER	151	WASHER 6		
123	FUEL CAP RETAINER	152	BRAKE TORSION ROD SPRING		

SO20121220



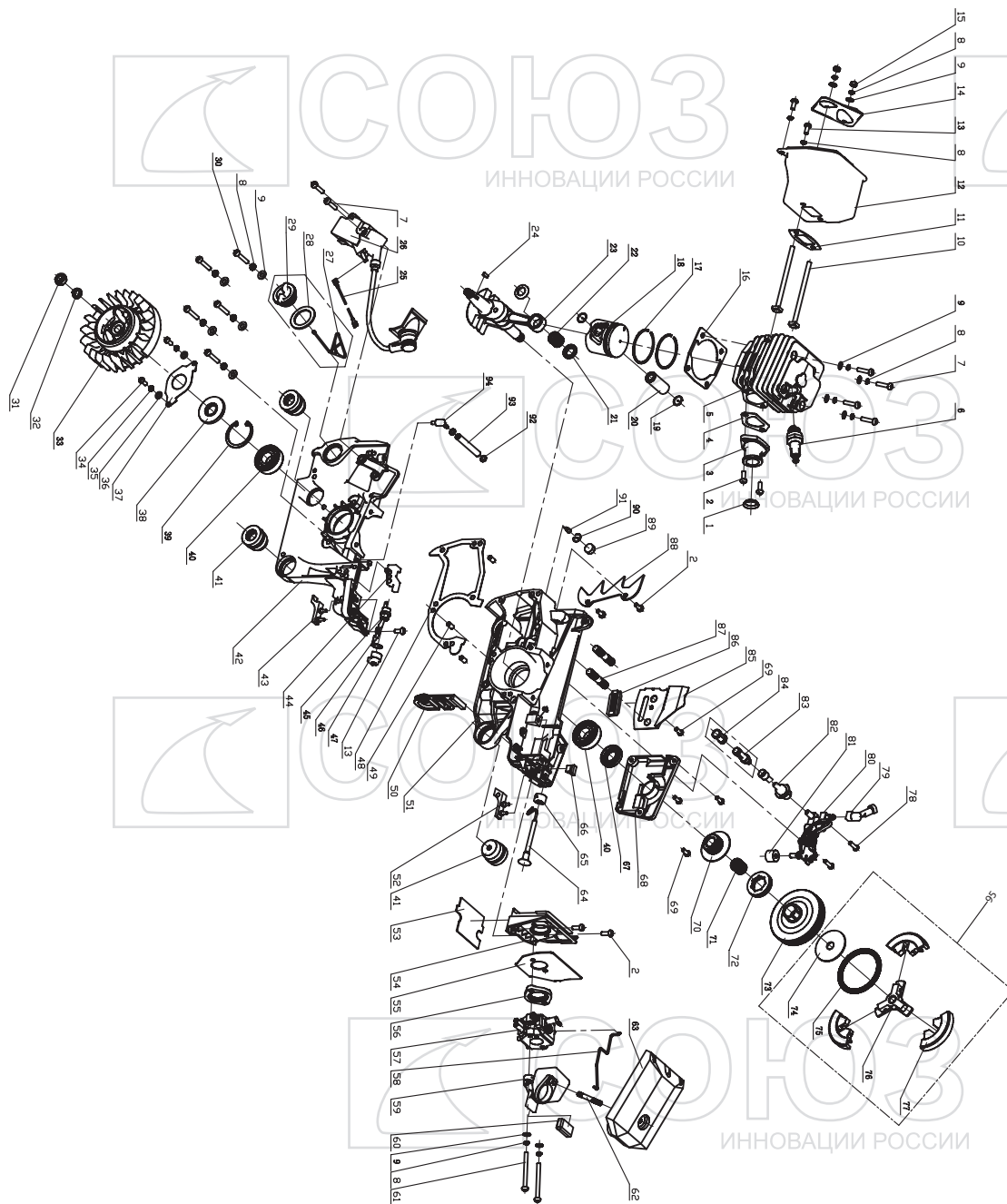

## БЕНЗОДВИГАТЕЛЬ ДЛЯ ПТС-99452Т

NO.	DESCRIPTION	NO.	DESCRIPTION	NO.	DESCRIPTION
1	RETAINER RING	33	FLYWHEEL	65	THROTTLE LEVER RETAINER
2	SCREW	34	SCREW	66	ANTI-SHOCK BLOCK 2
3	AIR INTAKE TUBE	35	SPRING WASHER	67	OIL SEAL
4	AIR INTAKE TUBE GASKET	36	WASHER	68	OIL PUMP COVER PLATE
5	CYLINDER	37	OIL SEAL PROTECTOR	69	SCREW
6	SPARK PLUG	38	OIL SEAL	70	WORM
7	SCREW	39	RING	71	NEEDLE BEARING
8	SPRING WASHER	40	BEARING 6202	72	SPROCKET
9	WASHER	41	ANTI-VIBRATION CUSHION D	73	CLUTCH SHELL
10	SILENCER BOLT	42	LEFT CRANKSHAFT CASE	74	CLUTCH WASHER
11	SILENCER GASKET	43	LEFT ANTI-SHOCK BLOCK	75	CLUTCH EXTENSION SPRING
12	SILENCER	44	ANTI-SHOCK BLOCK 1	76	RETAINER
13	SCREW	45	FLAMEOUT SWITCH	77	SHOE BLOCK
14	SILENCER CAP	46	GROUND STRIP	78	SCREW
15	NUT	47	FLAMEOUT SWITCH RETAINER	79	OIL NOZZLE
16	CYLINDER GASKET	48	CRANKSHAFT CASE GASKET	80	OIL PUMP
17	PISTON RING	49	PIN	81	SPONGE RING
18	PISTON	50	DUST PLATE	82	OIL TUBE
19	PISTON PIN CIRCLIP	51	RIGHT CRANKSHAFT CASE	83	OIL FILTER BODY
20	PISTON PIN	52	RIGHT ANTI-SHOCK BLOCK	84	OIL FILTER SCREEN
21	NEEDLE BEARING RING	53	BACKING BOARD	85	PROTECTING SHIELD
22	NEEDLE BEARING	54	AIR INTAKE TUBE SUPPORT	86	CHAIN GUIDE
23	CRANKSHAFT COMPONENTS	55	AIR INTAKE TUBE SUPPORT GASKET	87	SCREW
24	SEMICIRCULAR KEY	56	AIR INTAKE FLANGE	88	SPIKED BUMPER
25	FLAMEOUT WIRE	57	CARBURETOR	89	SPONGE BLOCK
26	IGNITER	58	ACCELERATOR ROD	90	AERATION NOZZLE CIRCLIP
27	OIL CAP RETAINER	59	AIR INTAKE	91	AERATION NOZZLE
28	PACKING WASHER	60	AIR INTAKE CUSHION	92	SUCTION TUBE CIRCLIP
29	OIL CAP	61	SCREW	93	SUCTION TUBE
30	SCREW	62	SCREW	94	SUCTION NOZZLE
31	NUT	63	AIR FILTER	95	CLUTCH ASSEMBLY
32	SPRING WASHER	64	THROTTLE ROD		

SO20121220

