

1040-03-GR

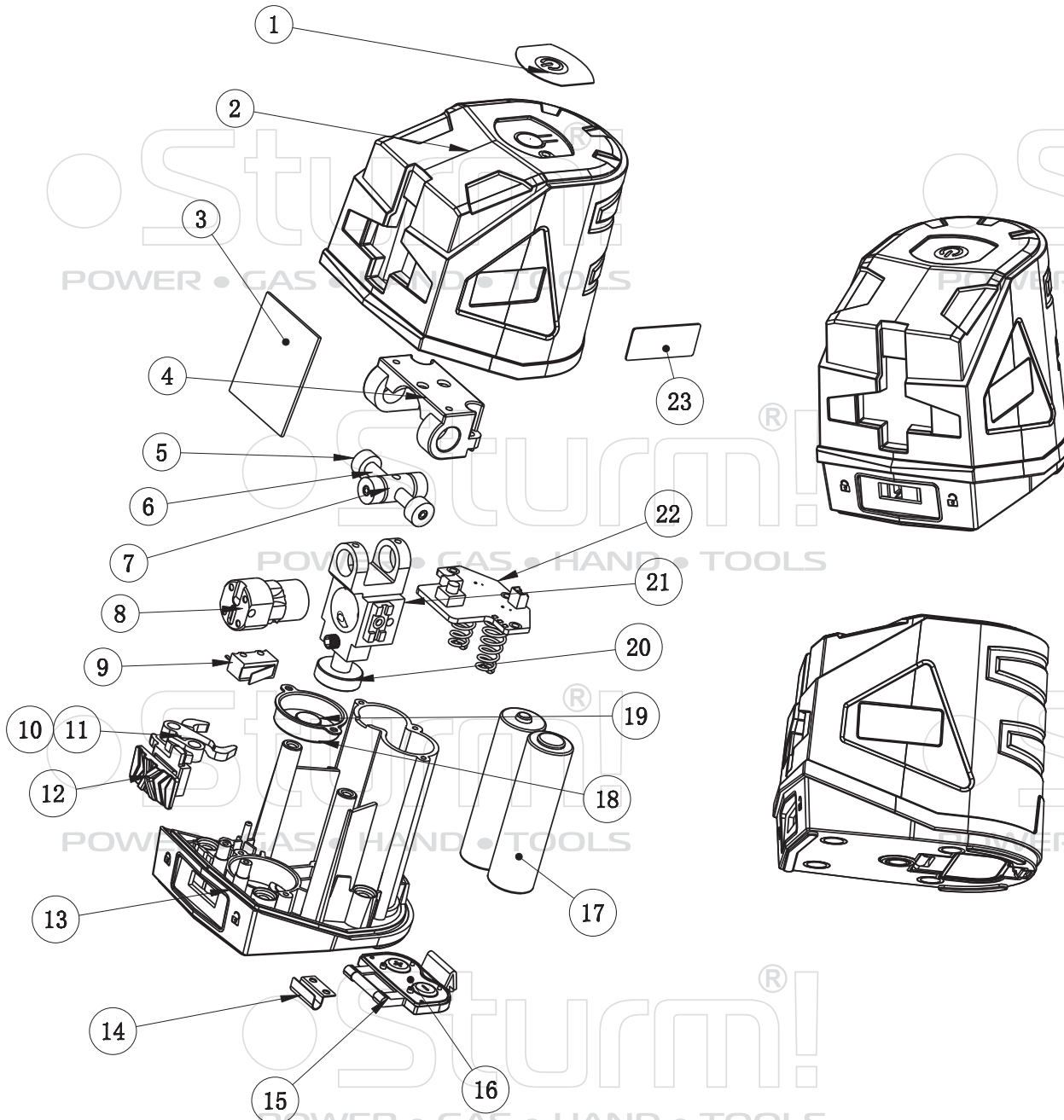

NO.	DESCRIPTION
1	BUTTON LABEL
2	HOUSING
3	GLASS
4	OUTRING
5	BEARING
6	INNER SHAFT SLEEVE
7	OUT SHAFT SLEEVE
8	LASER MOUDLE
9	MICROSWITCH
10	SWITCH RIGHT ARM
11	SWITCH LEFT ARM
12	PUSH SWITCH
13	BASE
14	BATTERY COVER HOLD
15	BATTERY COVER
16	BATTERY STAMPING
17	BATTERY
18	MAGNET SUPPORT
19	MAGNET
20	HEAVEY HAMMER
21	PENDULUM
22	MAIN BOARD
23	LABEL