

1040-16-GR

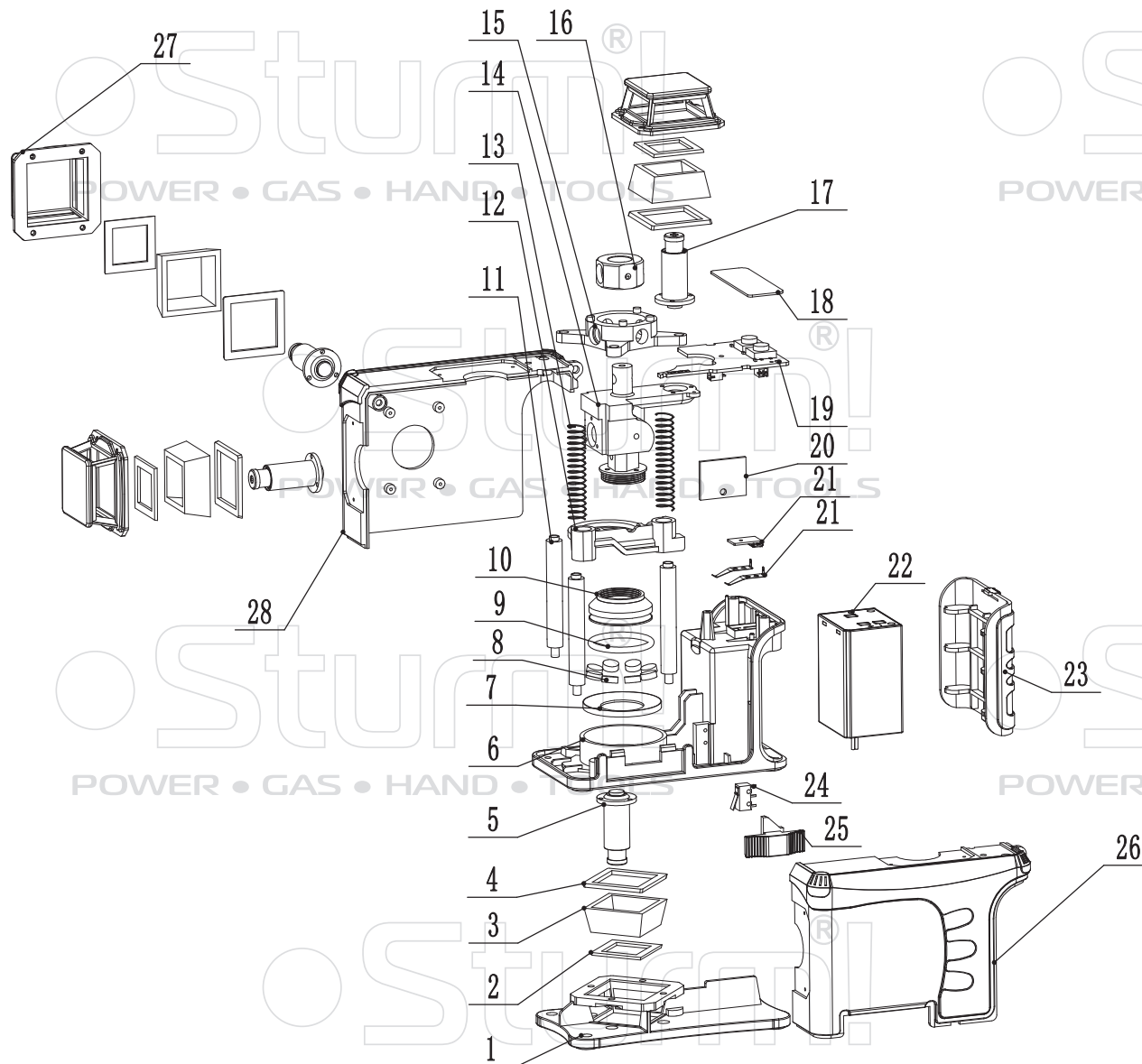

NO.	DESCRIPTION
1	DOWN COVER
2	SMALL WINDOW PLATE
3	GLASS
4	BIG WINDOW PLATE
5	360 LASER
6	BASE
7	MAGNET PIECE
8	MAGNET
9	CONDUCTIVE RING
10	HAMMER
11	COLUMN
12	SWITH PUSH
13	COLUMN SPRING
14	PENDULUM
15	OUTTER RING
16	INNER RING
17	360 LASER
18	LABEL
19	MAINBOARD
20	STEP-DOWN PINBOARD
21	USB COMPLETE
22	BATTERY
23	BATTERY BACK COVER
24	MICRO SWITCH
25	SWITCH BUTTON
26	HOUSING LEFT
27	OPEN WINDOW
28	HOUSING RIGHT