

AW97I210D

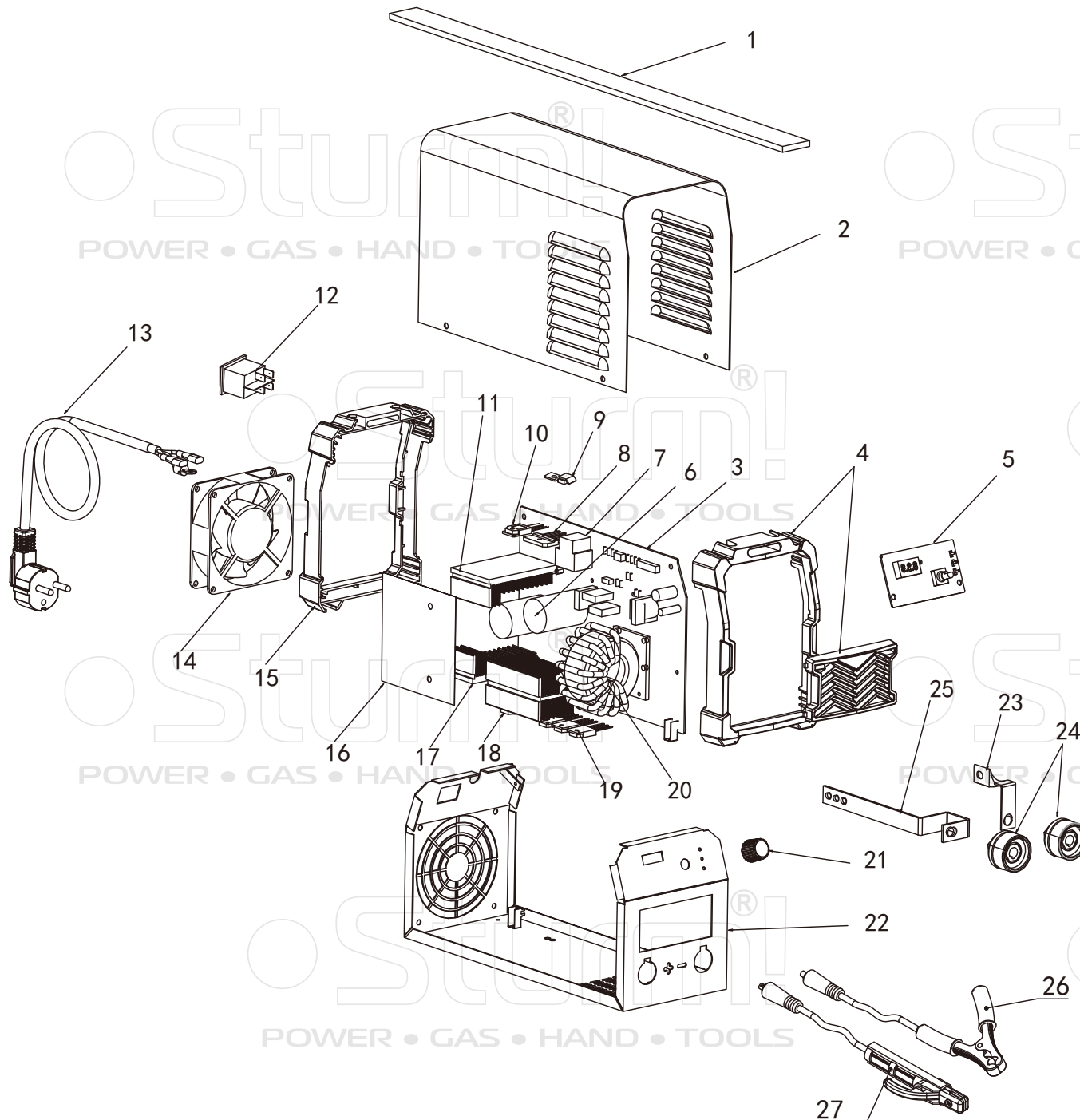

NO.	DESCRIPTION
1	HANDLE
2	COVERS SHEET
3	BOARD ASSEMBLY
4	PLASTIC PANEL 1
5	CONTROL PANEL
6	CAPACITY2
7	RELAY
8	BRIDGE RECTIFIER
9	TEMPERATURE SWITCH
10	IGBT
11	HEAT SINKS 1
12	SWITCH
13	POWER CABLE
14	FAN
15	PLASTIC PANEL 2
16	INSULATION BOARD
17	HEAT SINKS 2
18	HEAT SINKS 3
19	DIODE
20	TRANSFORMER
21	POTENTIOMETER HAT
22	BOTTOM SHELL
23	COPPER JOINT
24	CONNECTOR
25	ALUMINUM JOINT
26	EARTH CLAMP
27	ELECTRODE HOLDER

AW97I210D FRONT-BOARD

