

AW97I2350D,AW97I2550D

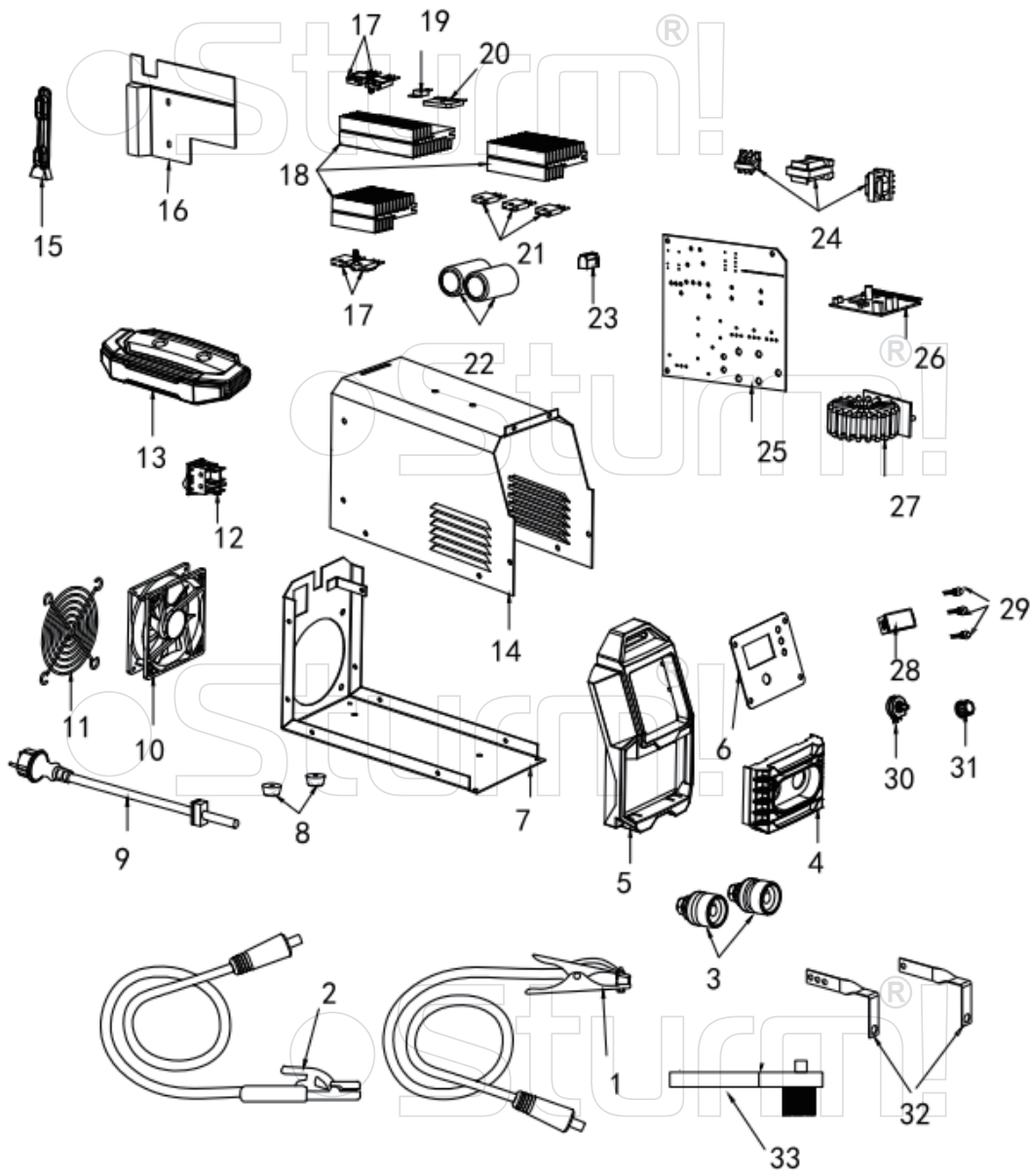

No	Description
1	Earth clamp 300A with 14mm 1m
2	Electrode holder 200A with 14mm 2m
3	Fast connector 10-25mm
4	Front of plastic for cooling
5	Front of plastic panel
6	Front of metal panel
7	Case on the bottom
8	sledge foot
9	Power cable 1.5m 2.5 ² Rubber
10	Fan high speed 5000 RPM
11	Fan net
12	30A Switch
13	Plastic handle
14	Case on the beside
15	Plastic support
16	Plastic parts for cooling
17	IGBT SL20N60PFD
18	Radiator (25Y circuit board)
19	NTC 90 °C
20	Rectifier bridge D35SB100
21	Fast recovery diode SL25U20
22	Capacitor 390UF/400V 85°C
23	Pc board palstc support parts
24	Samll transformer
25	Whole pcb board with all component
26	Signal board PKB-200
27	Main Transformer T56X28X20 25:5
28	Display board
29	LED Lamp
30	Potentiometer
31	knob
32	copper bar
33	steel brush

UK-ST20210310

AW97I2350D,AW97I2550D FRONT-BOARD

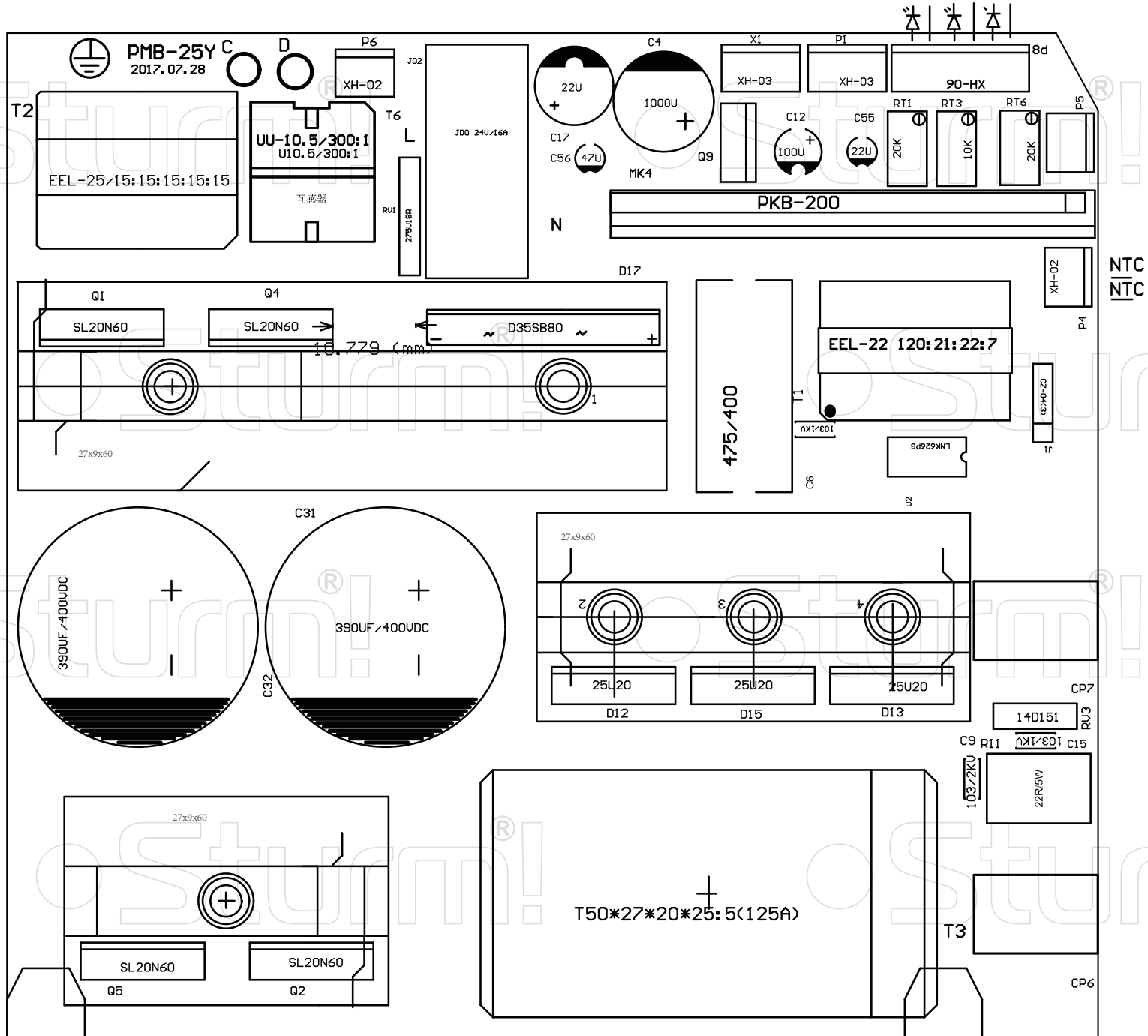

AW97I2350D,AW97I2550D BACK-BOARD

