

AW97I300D

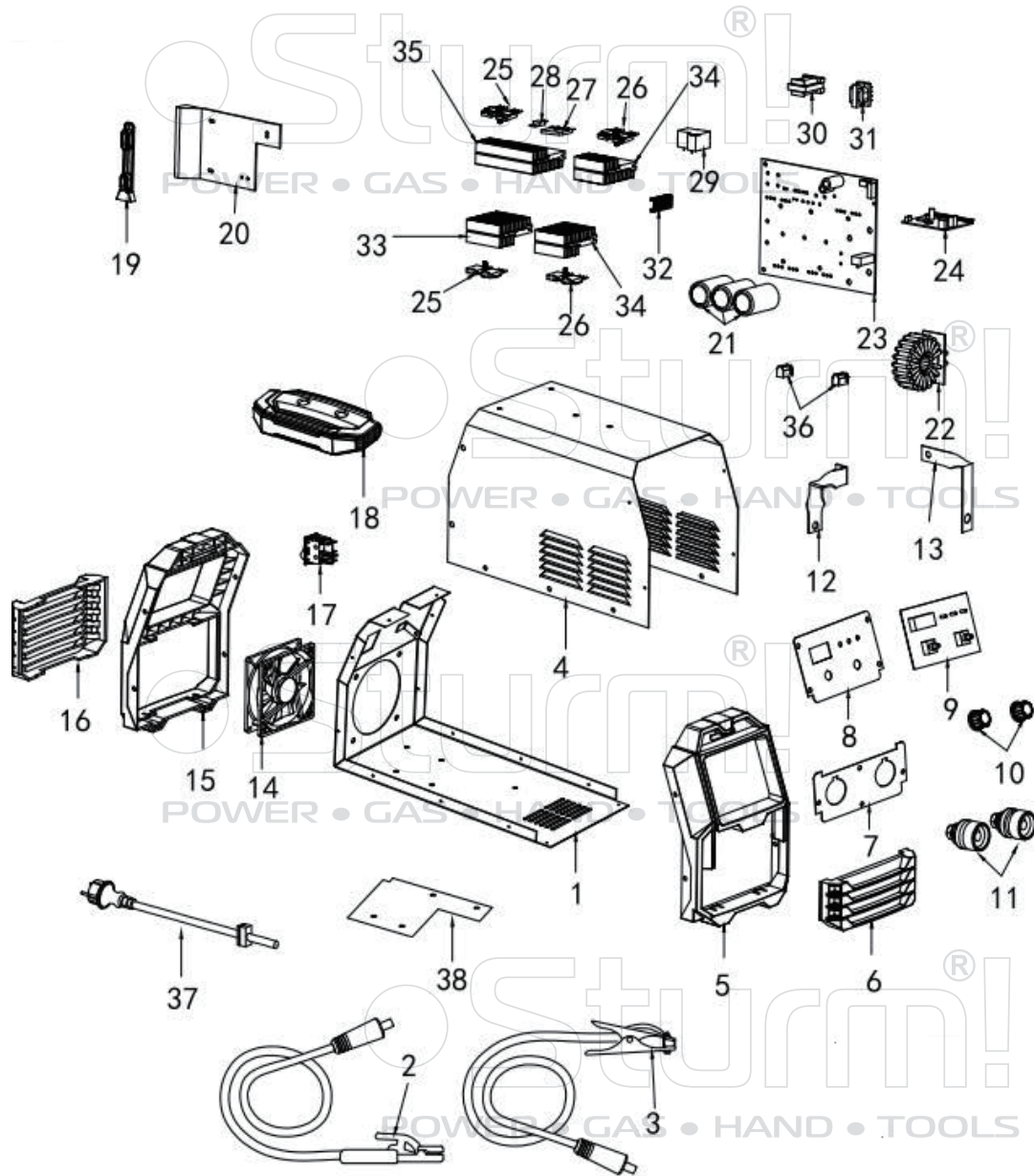

No	Description	No	Description
1	Bottom case	20	Plastic Wind board
2	3M 16 ² cable with 300A electrode holder	21	470UF/400V 85°C Capacitor
3	3M16 ² cable with 300A earth clamp	22	Main transformer
4	Case on the beside	23	whole pc board (10T)
5	Front of Plastic panel	24	Pwm board
6	Front of plastic for cooling	25	Silan 60N60 IGBT
7	Fast connect metal	26	Silan 60F30 IGBT
8	Front of metal panel	27	D35SB100 rectifier bridge
9	Display board	28	90degree NTC
10	Knob	29	Relay xinda 30A
11	Fast connect 35-50mm	30	Small Transformer
12	Copper bar	31	Drive Transformer
13	Copper bar	32	Radiator (1)
14	Fan 5000 RPM	33	Radiator (2)
15	Back of platic panel	34	Radiator (3)
16	back of plastic for cooling	35	Radiator (4)
17	Power switch 30A	36	Circuit board pad block
18	Plastic handle	37	Power cable 3x2.5 ²
19	Plastic support	38	epoxy plate

AW97I300D FRONT-BOARD

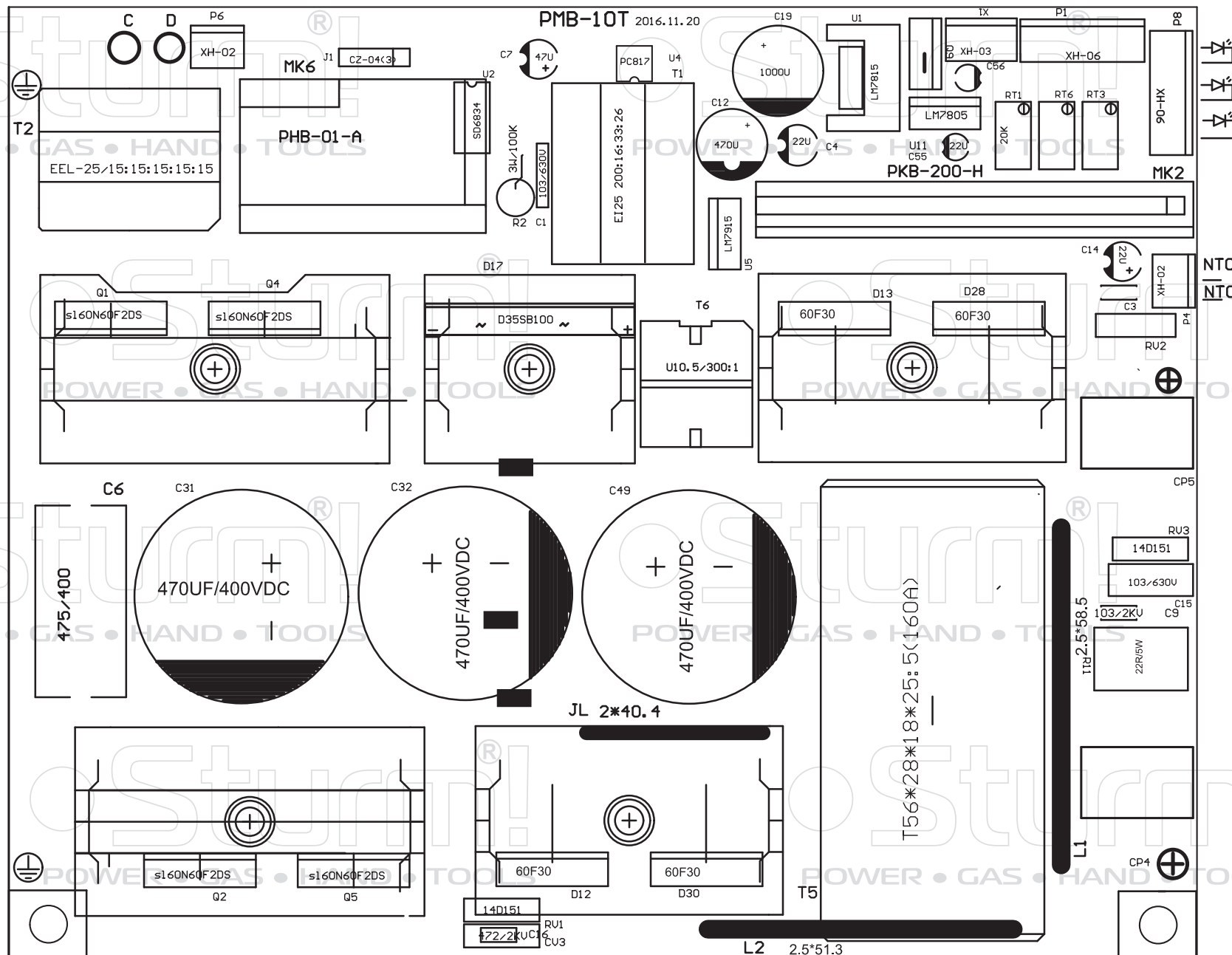

AW97I300D BACK-BOARD

PMB-10T 2016.11.20

