

BC8080

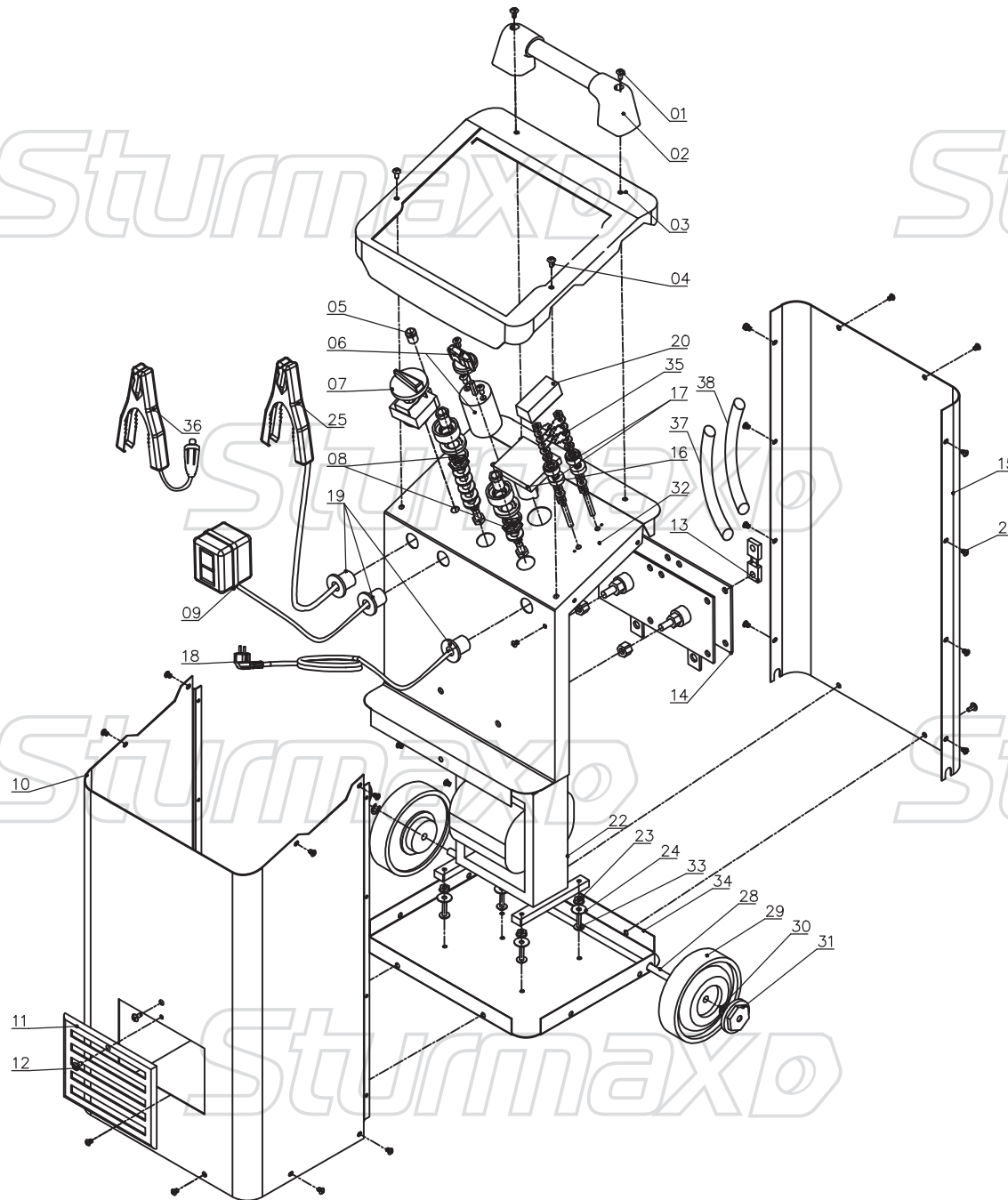

NO.	DESCRIPTION
1	HANDLE FASTENING SCREW
2	HANDLE
3	PLASTIC PANEL
4	PLASTIC PANEL FASTENING SCREW
5	OVERHEAT PROTECTION LED
6	MODE REGULATION SWITCH
7	TIMING SWITCH
8	EURO CONNECTOR
9	REMOTE CONTROL SWITCH
10	FRONT METAL PANEL
11	VENTILATION WINDOW
12	VENTILATION WINDOW FASTENING SCREW
13	SHUNT
14	RECTIFIER BRIDGE
15	BACK METAL PANEL
16	AMPEREMETER
17	333 TERMINAL SET
18	POWER CABLE
19	CABLE FASTENER
20	PLASTIC PROTECTION COVER
21	FASTENING SCREW FOR METAL PIECE
22	MAIN TRANSFORMER
23	FLANGE NUT
24	FLAT WASHER
25	NEGATIVE CHARGING CLAMP SET
28	WHEEL AXLE
29	WHEEL
30	CIRCLIP
31	WHEEL PLASTIC COVER
32	TOP METAL PANEL
33	MAIN TRANSFORMER FASTENING SCREW
34	BOTTOM METAL PANEL
35	FUSE
36	POSITIVE CHARGING CLAMP SET
37	CABLE A
38	CABLE B