

# Sturm!®

## BS8511U

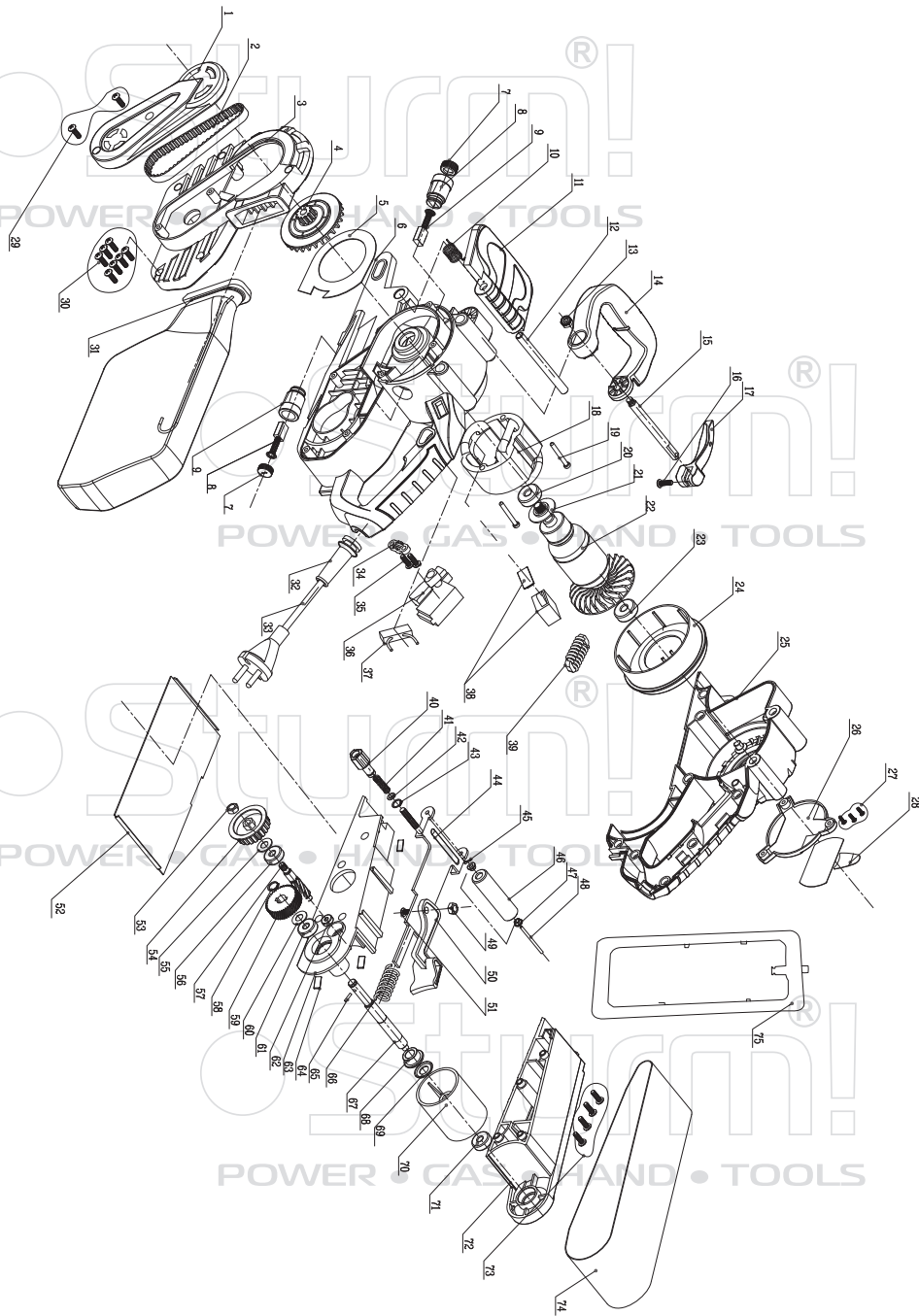

NO.	DESCRIPTION	NO.	DESCRIPTION
1	BELT COVER	39	INDUCTOR
2	SYNCHRONOUS BELT	40	ADJUST KNOB
3	MIDDLE COVER	41	SMALL SPRING
4	SMALL PULLEY	42	WASHER Ø13XØ6X1
5	WIND CIRCLE	43	CHECK RING
6	LEFT HOUSING	44	FRONT-WHEEL FRAME
7	BRUSH COVER GRIP	45	FIXED SALES
8	BRUSH HOLDER	46	FRONT WHEEL
9	BRUSH	47	NEEDLE BEARING HK0609
10	TORSION SPRING	48	FRAME AXIS
11	ACTIVITIES OF THE SHAFT PLATE	49	Ø6 WASHER
12	AXIS OF ROTATION	50	FRONT-WHEEL FRAME WRENCH
13	NUT	51	Ø6 RIVET
14	FRONT HANDLE	52	IRON BOTTOM
15	SCREW M6	53	NUT M6
16	SCREW ST4.2X16	54	LARGE PULLEY
17	FORMER HANDLE WRENCH	55	WASHER Ø8
18	STATOR	56	BEARING 627RS
19	SCREW ST5X50	57	SMALL GEAR SHAFT
20	BALL BEARING 608RS	58	PLAIN WASHER
21	INSULATION SPACER	59	BIG GEAR
22	ROTOR	60	WASHER Ø8
23	BALL BEARING 608RS	61	BEARING 608RS
24	INTRODUCTION SETS OF WIND	62	BALL BEARING 606
25	RIGHT HOUSING	63	ALUMINUM BASE
26	NAMEPLATE DECORATIVE COVER	64	CERAMIC SHEET
27	SCREW ST2.9X12	65	CYLINDRICAL PIN Ø3X11
28	NAMEPLATE	66	SPRING
29	SCREW ST4.2X16	67	REAR AXLE
30	SCREW ST4.2X16	68	COPPER SETS
31	DUST ADAPTER	69	BOWL-TYPE GASKET
32	CABLE GUARD	70	REAR WHEEL
33	CABLE	71	BALL BEARING 626
34	CABLE PRESS BOARD	72	PLASTIC BRACKET
35	SCREW ST4.2X16	73	SCREW ST4.2X40
36	SWITCH	74	SANDING BELT
37	CAPACITOR0.22UF	75	STEEL FRAME
38	DECORATIVE COVER & SPEED CONTROL SWITCH		

UK-ST20150624

POWER • GAS • HAND • TOOLS