

AG9020CLS

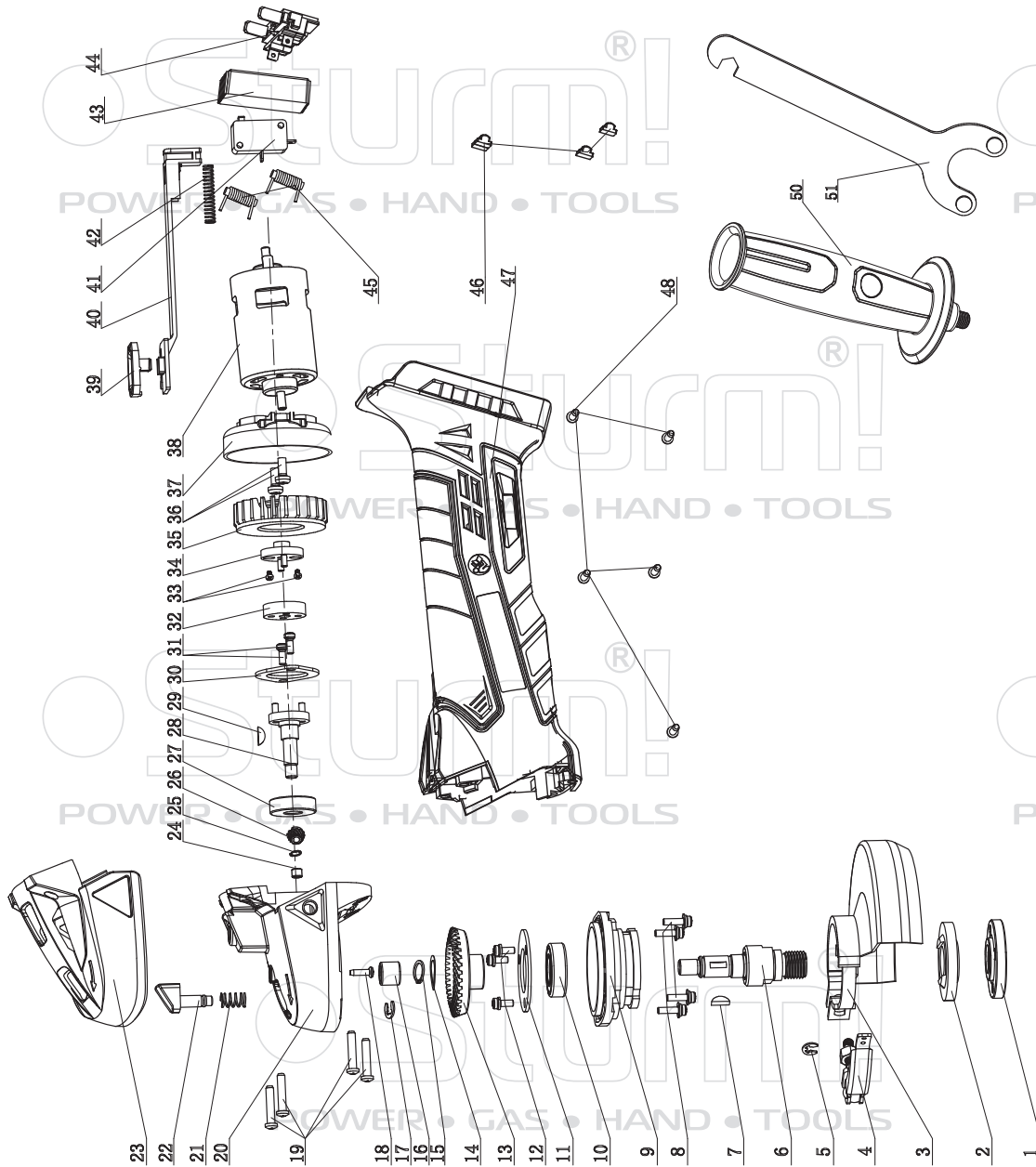

NO.	DESCRIPTION
1	OUTER FLANGE
2	INNER FLANGE
3	PROTECTION SHIELD
4	QUICK-CHANGE GASKET
5	Ø4 SPLIT WASHER TYPE E
6	OUTPUT SPINDLE
7	WOODRUFF KEY 3X10
8	M4*12 SCREW
9	FRONT COVER
10	6001-2Z BEARING
11	PRESSURE PLATE FOR BEARING
12	M4*8 SCREW
13	BIG GEAR
14	WAVE WASHER Ø11
15	CIRCLIP FOR AXIS Ø10
16	NEEDLE BEARING HK0810
17	CIRCLIP Ø5
18	ST3*10 TAPPING SCREW
19	ST4*20 TAPPING SCREW
20	HEAD HOUSING
21	SELF-LOCK SPRING
22	SELF-LOCK PIN
23	DECORATIVE COVER
24	SLIDE BEARING Ø8XØ6X6
25	CIRCLIP FOR AXIS Ø6
26	SMALL GEAR
27	609-2Z BEARING
28	CONNECTING SHAFT
29	WOODRUFF KEY 2.5*3.7*10
30	PRESSURE PLATE FOR BEARING
31	M4*8 SCREW
32	DRIVING DISC
33	ST3*8 SCREW
34	FLANGE
35	FAN
36	M5*8 SCREW
37	WINDSHIELD
38	MOTOR
39	SWITCH PUSH BUTTON
40	SWITCH LEVER
41	SWITCH
42	SPRING OF PUSH BUTTON
43	SOFT START
44	CONNECT PLATE HOLDER
45	ROD INDUCTOR
46	RUBBER BLOCK
47	HOUSING
48	ST3.5*16 SCREW
50	SIDE HANDLE
51	WRENCH