

Sturm!

CS50190P

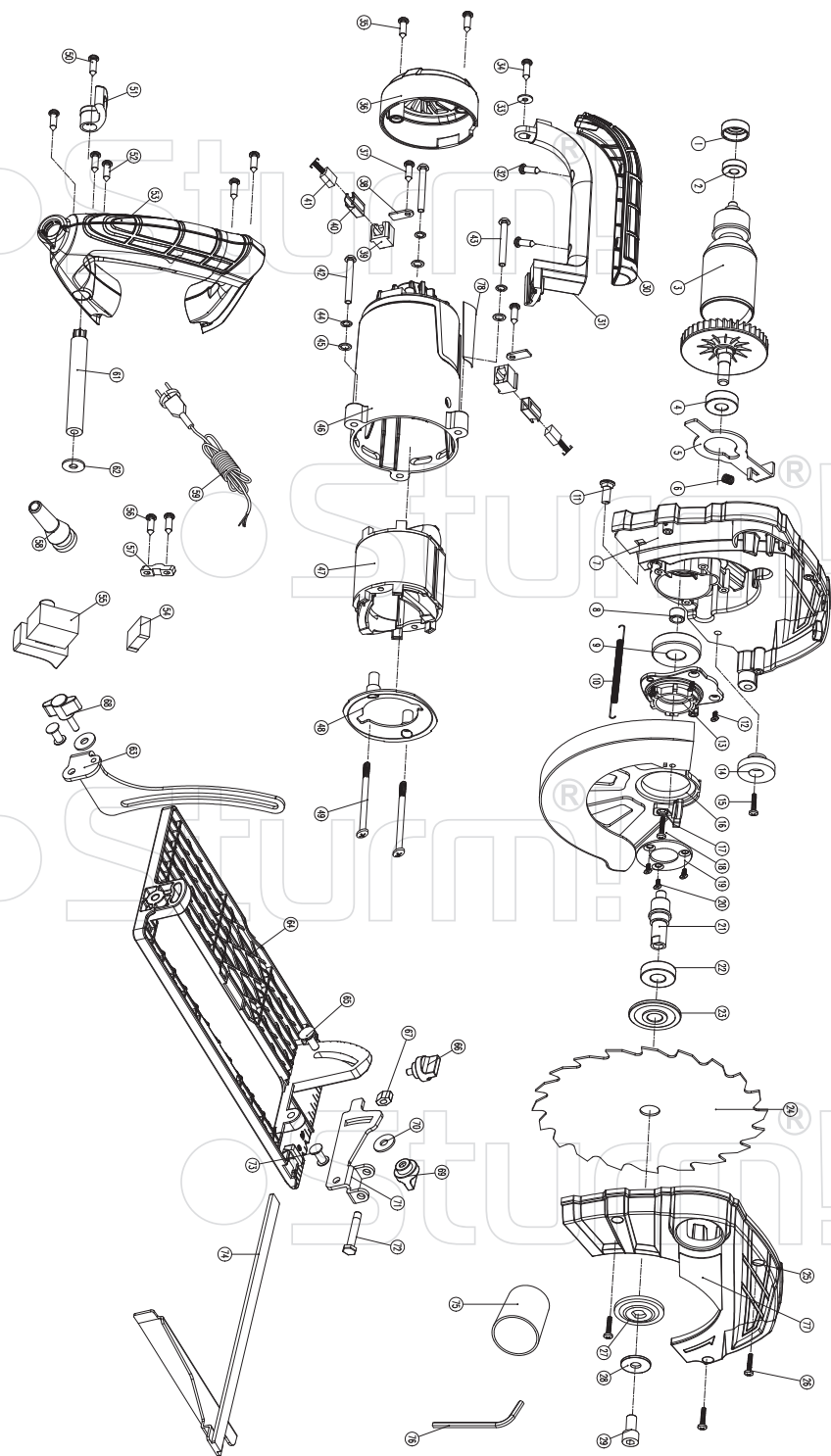

NO.	DESCRIPTION	NO.	DESCRIPTION
1	bearing bush	39	brush holder
2	bearing (607 RS)	40	brush housing
3	rotor	41	carbon brush
4	bearing (6000 RS)	42	screw M5*30
5	bearing wrench	43	screw M5*40
6	spring	44	washer 5
7	aluminium housing	45	spring washer
8	oil bearing	46	housing
9	gear	47	stator
10	spring	48	protection ring
11	Lifting bolt	49	cross tapping screw ST4.1*80
12	cross tapping screw M4*12	50	cross tapping screw ST4.1*16
13	gear case cover	51	knob
14	circlip	52	cross tapping screw ST4.1*16
15	cross tapping screw M6*12	53	handle
16	safety cover	54	capacitance
17	wrench	55	switch
18	screw M4x6	56	cross tapping screw ST4.1*16
19	bearing press board	57	wire strain plate
20	cross tapping screw M4*10	58	cable sheath
21	output shaft	59	cable
22	bearing 6001 2Z	61	cable sleeve
23	blade seat	62	washer 6
24	blade	63	control bracket
25	aluminium cover	64	aluminium base
26	screw M4x16	65	bolt
27	saw blade cover plate	66	knob
28	washer 8	67	nut M6
29	hex screw M8x16	68	knob
30	additional handle cover	69	knob
31	additional handle	70	washer 6
32	cross tapping screw ST4.1*16	71	bracket
33	washer 4	72	bolt M6X20
34	cross tapping screw ST4.1*13	73	Flat head hollow rivet Ø 6 x16
35	cross tapping screw ST4.1*16	74	depth stop
36	rear cover	75	dust tube
37	cross tapping screw ST4.1*13	76	Allen key 6mm
38	clamp		