

PARTS CATALOGUE FOR ENGINE

DT-8807X

ДТ-8807

VERSION No. : 20120606-01

1、 Unit assembly

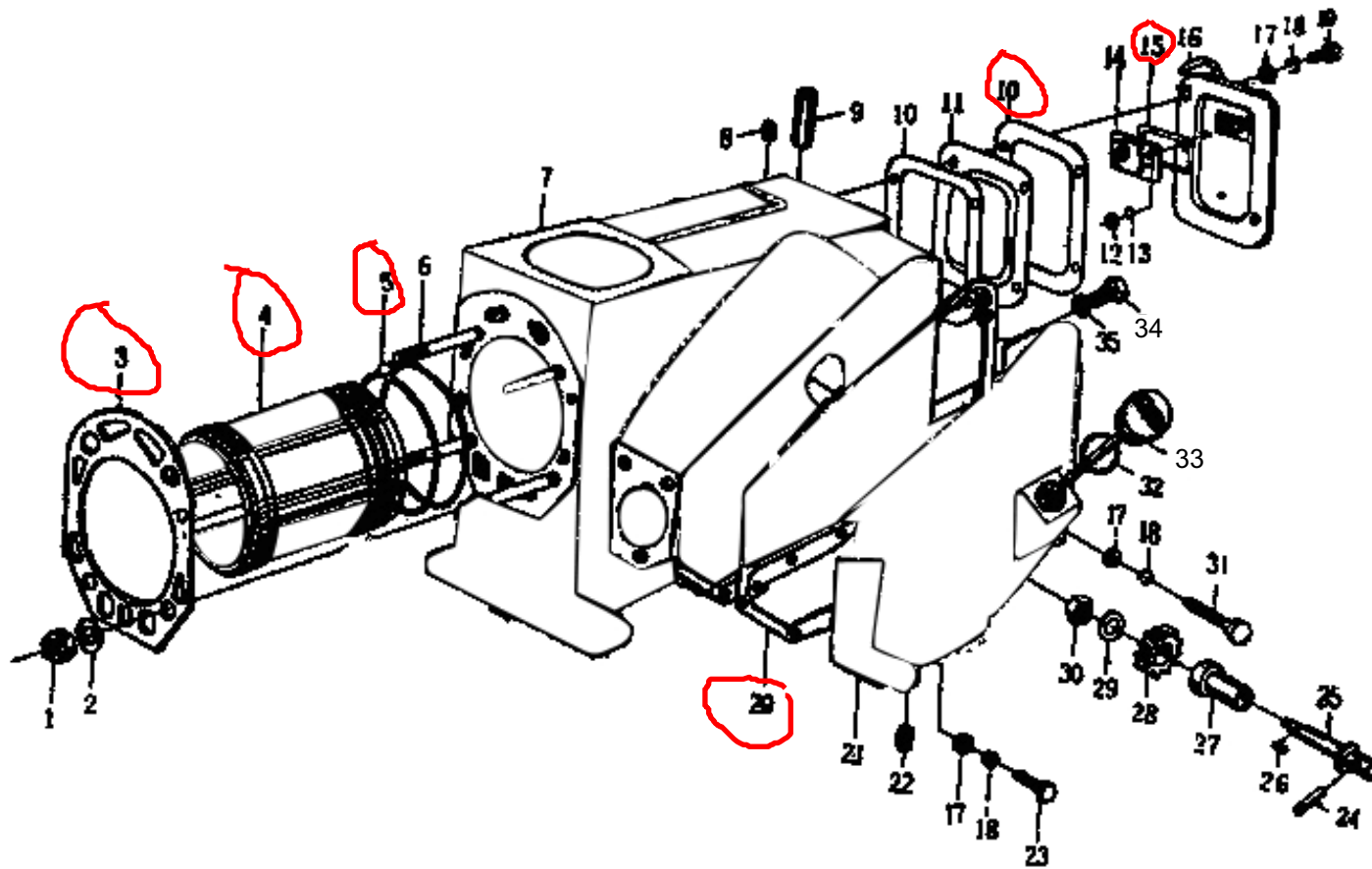

1、 Unit assembly

No.	Parts name	No.	Parts name
1	Cylinder head nut	19	Bolt M6×16
2	Washer	20	Gear case cover washer
3	Cylinder head washer	21	Gear case cover
4	Cylinder cover	22	Gear case cover choker
5	Cylinder cover water sealing	23	Bolt M6×20
6	Cylinder cover double head bolt	24	Pin 8×28
7	Unit body	25	Starter shaft
8	Choker	26	Pin C5×10
9	Adjusting lever shaft bushing	27	Starter shaft bushing
10	Rear cover washer	28	Starter gear
11	Respirator inner partition board	29	Washer
12	Nut M5	30	Nut M8
13	Washer	31	Bolt M6×35
14	Respirator solder part	32	engine oil filling washer
15	Washer	33	Oil ruler
16	Respirator cover solder part	34	Oil drain screw plug
17	Washer	35	Oil drain plug washer
18	Washer		

2、Cylinder head assembly

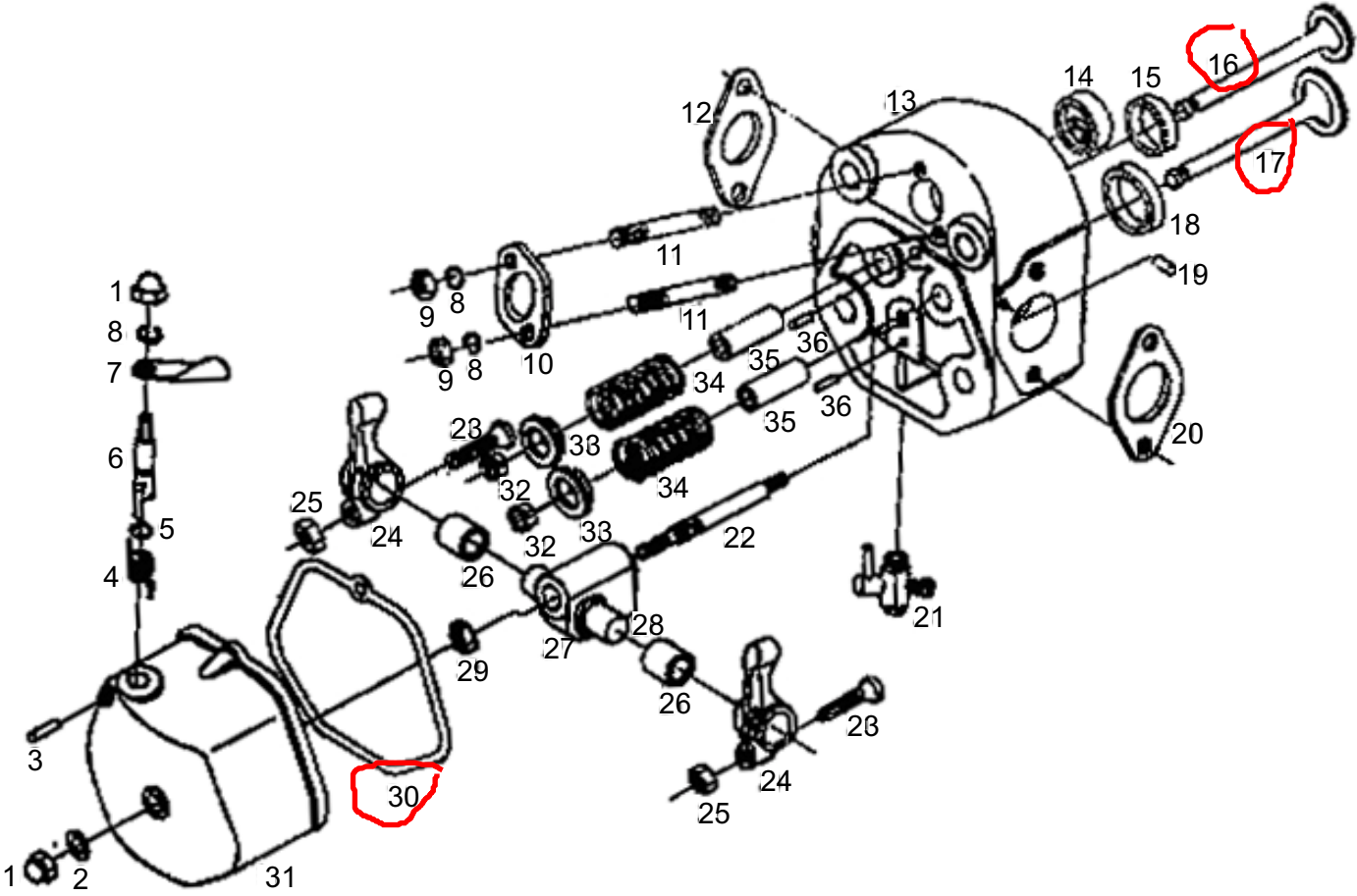

2、Cylinder head assembly

No.	Parts name	No.	Parts name
1	Nut M8	19	Choker
2	Washer GB848-85-8-140HV	20	Intake pipe washer
3	Pin GB119-86B3×20	21	Water drain assembly
4	Pressure-reducing shaft spring	22	Bolt
5	“O” Ring 10×1.9HG4-333-66	23	Valve clearance adjusting screw
6	Pressure-reducing shaft	24	Valve rocker
7	Pressure-reducing handle	25	Nut GB6172-86-M8
8	Washer GB93-87 8	26	Valve rocker bushing
9	Nut GB6170-86-M8	27	Rocker base
10	Oil injector pressure plate	28	Rocker shaft
11	Bolt AM8×55	29	Nut GB6170-86-M10
12	Vent-pipe washer	30	Cylinder head cover washer
13	Cylinder head	31	Cylinder head cover
14	Panel block	32	Valve cotter
15	Exhaust valve base	33	Valve Spring Retainer
16	Exhaust valve	34	Valve Spring
17	Intake valve	35	Valve guide
18	Intake valve base	36	Position pin

3、Piston and connecting rod assembly

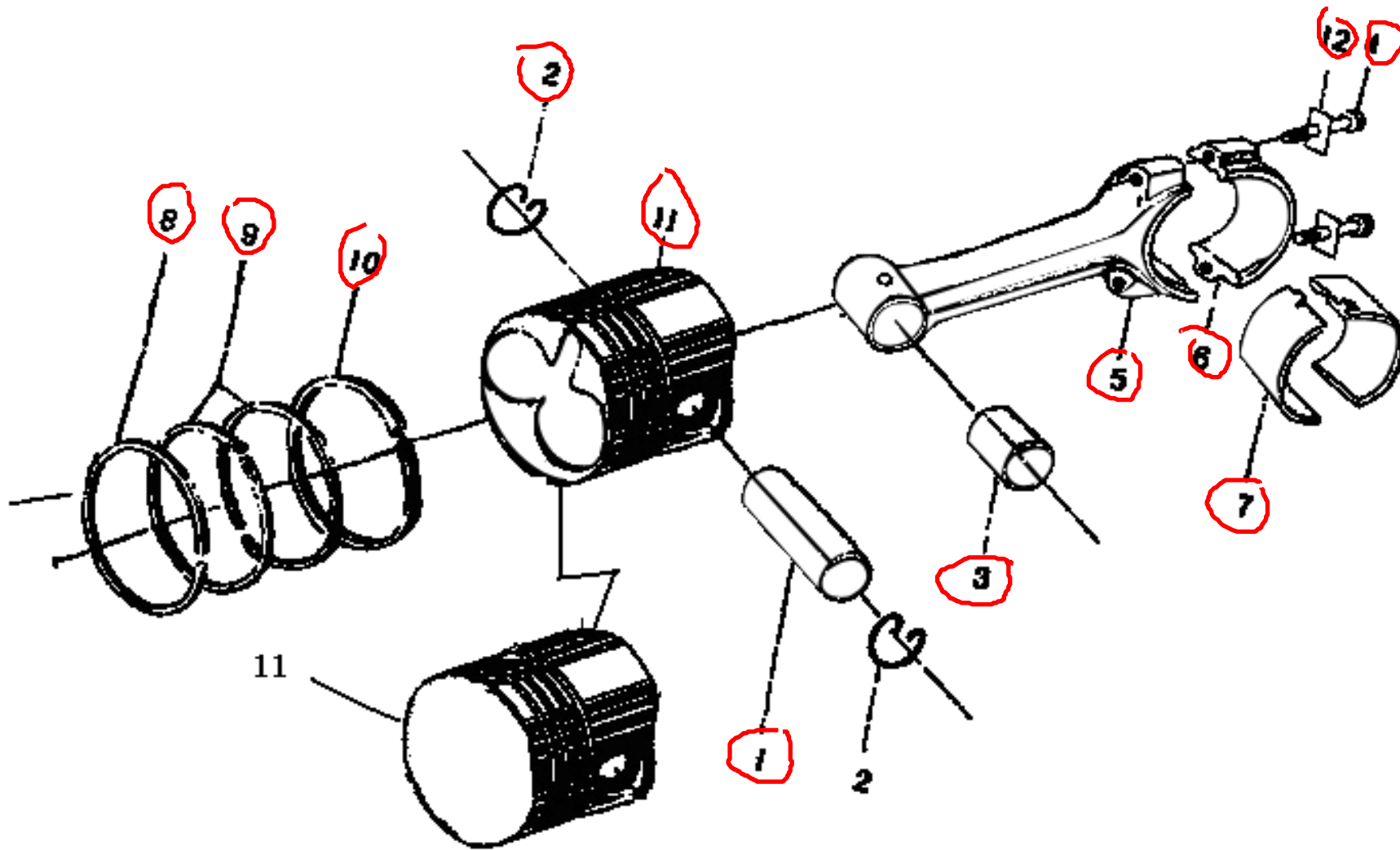

3、 Piston and connecting rod assembly

No.	Parts name
1	Piston pin
2	Piston pin retaining ring
3	Connecting rod bushing
4	Connecting rod bolt
5	Connecting rod
6	Connecting rod cover
7	Connecting rod bearing shell
8	First gaseous ring
9	Second, third gaseous ring
10	Oil ring assembly
11	Piston
12	Connecting rod bolt safety plate

4、Crankshaft and flywheel assembly

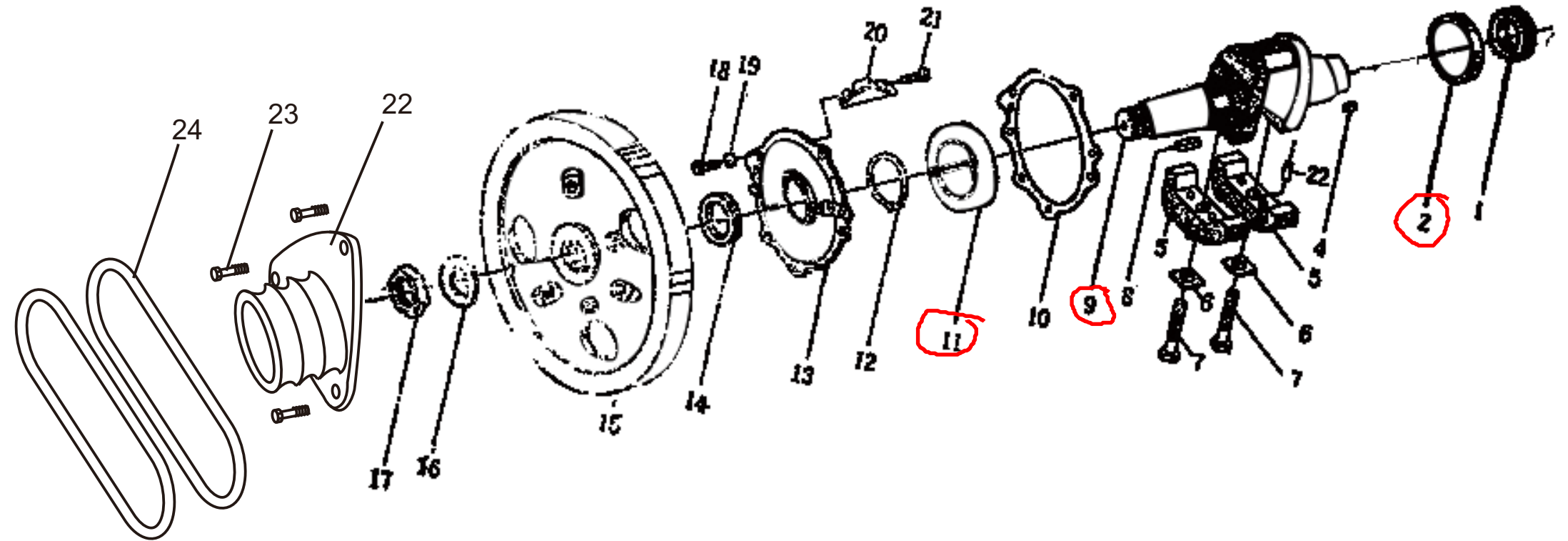

4、Crankshaft and flywheel assembly

No.	Parts name
1	Crankshaft timing gear
2	Bearing 210
4	Key C5×15
5	Balance weight
6	Lock washer
7	Balance weight bolt
8	Flywheel flat key
9	Crankshaft
10	Bearing base washer
11	Bearing 310
12	Retainer ring
13	Bearing base
14	Oil sealing SD45×62×12
15	Flywheel
16	Flywheel lock plate
17	Flywheel nut
18	Bolt GB5783-86-M8×20
19	Washer GB93-87-8
20	Thrust plate
21	Bolt GB5783-86-M6×12
22	Pulley wheel
23	Bolt
24	Belt B1700

5、Camshaft assembly

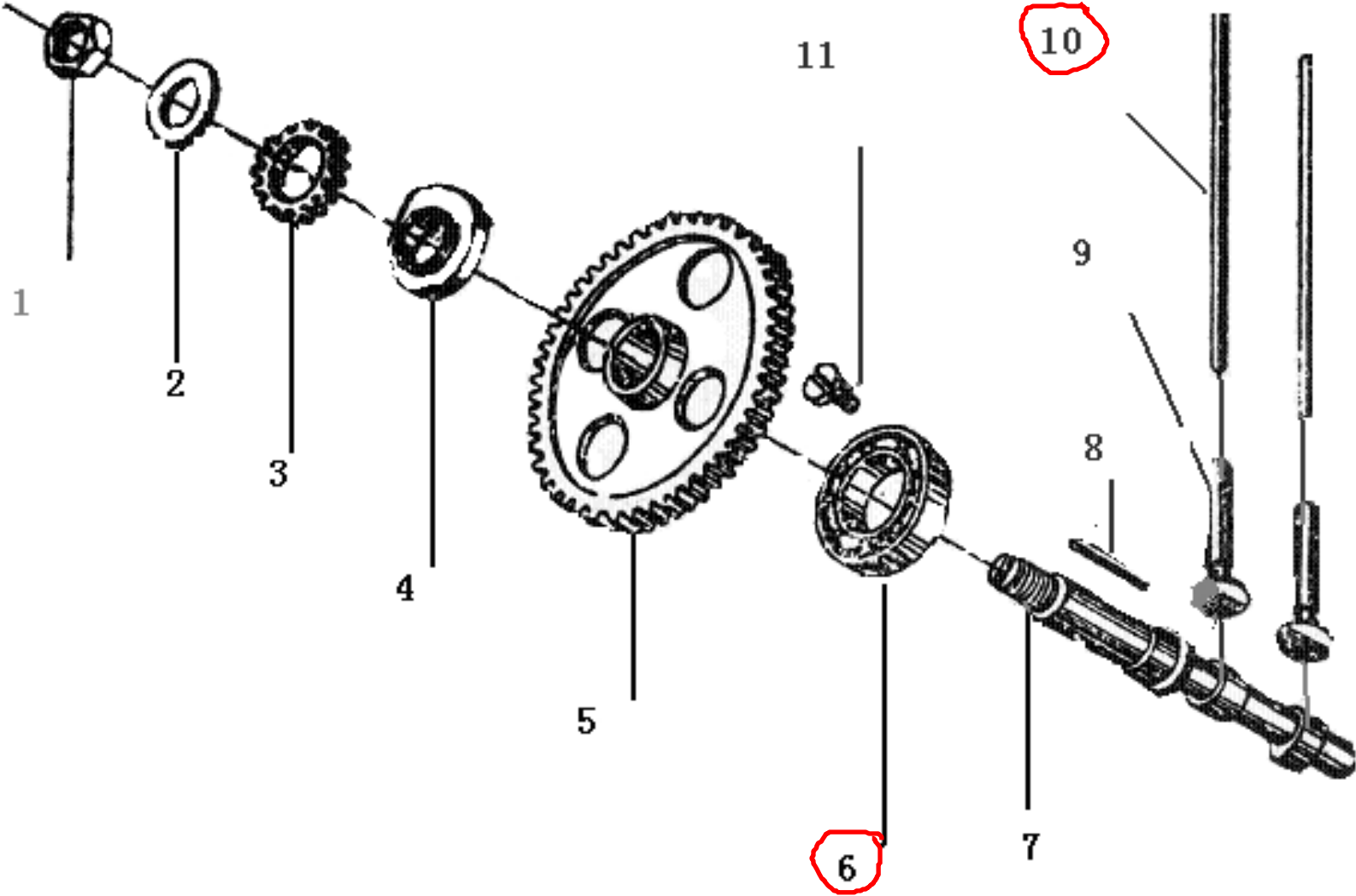

5、Camshaft assembly

No.	Parts name
1	Nut
2	Camshaft washer
3	Starter gear
4	Oil injection pump camshaft
5	Camshaft timing gear
6	Roll bearing 205
7	Camshaft
8	Key C5×46
9	Valve lifer
10	Valve push rod
11	Camshaft thrust screw

6、 Intake system

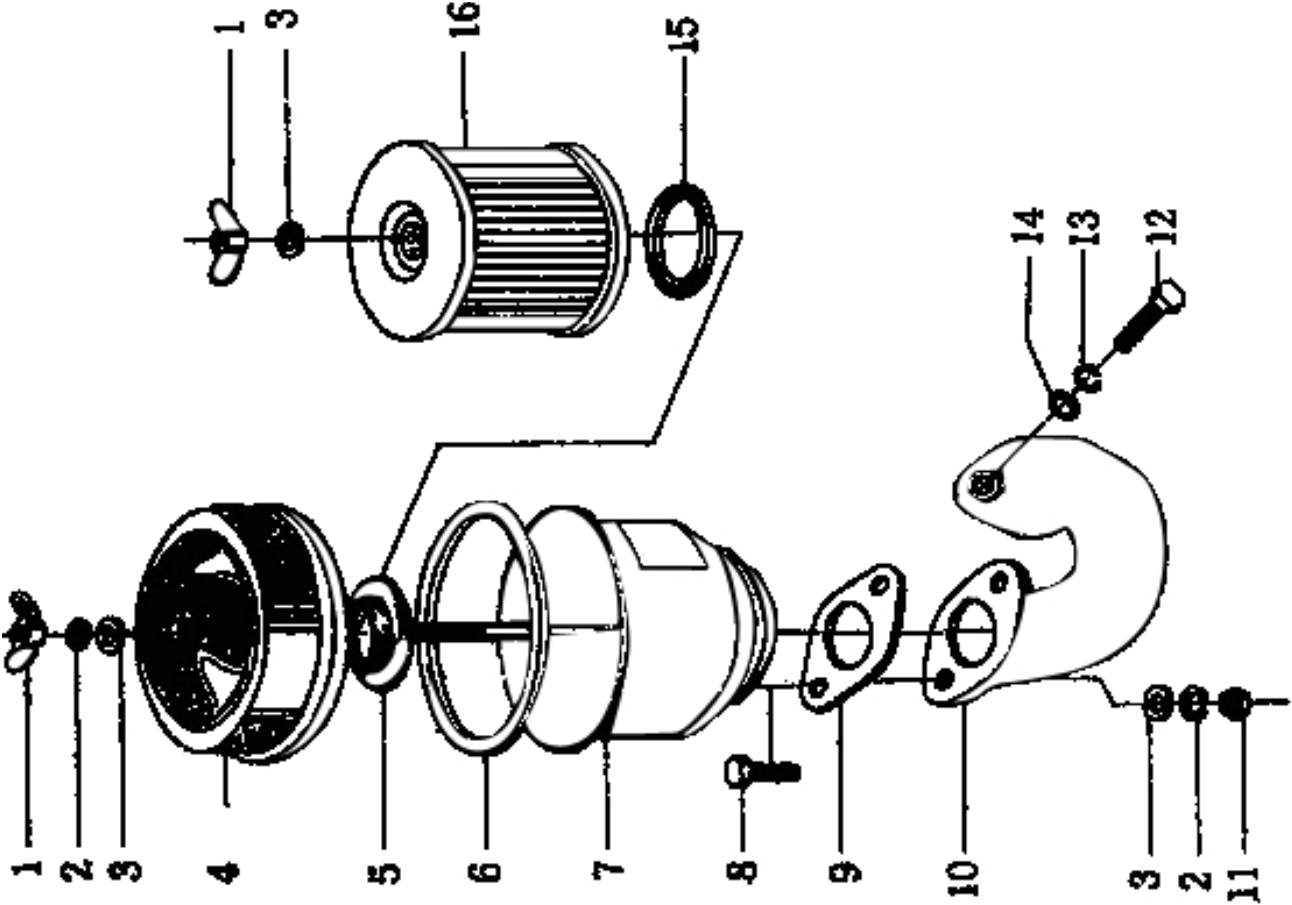

6、 Intake system

No.	Parts name
1	Nut M6
2	Washer
3	Washer
4	Filter housing (upper)
5	Supporting ring
6	Sealing ring
7	Filter housing (down)
8	Bolt
9	Air filter washer
10	Intake pipe
11	Nut
12	Bolt
13	Washer
14	Washer
15	Filter sealing ring
16	Filter element

7、 Exhaust system

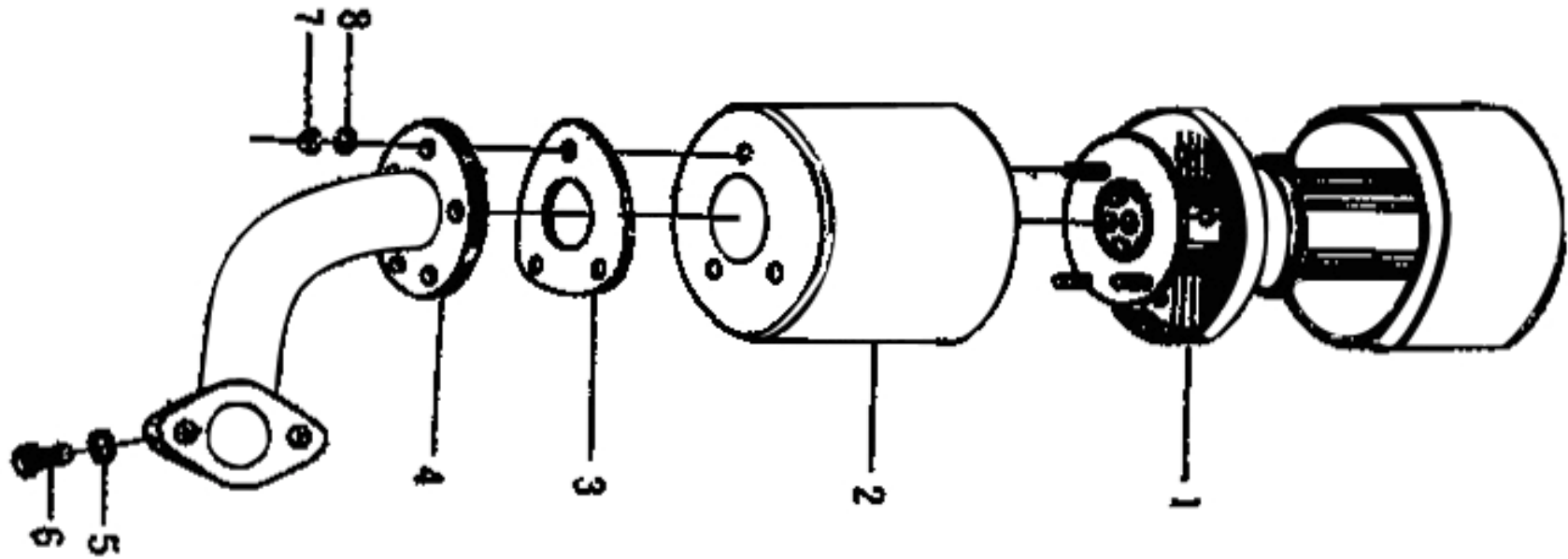

7、 Exhaust system

No.	Parts name
1	Muffler solder part
2	Muffler
3	Muffler washer
4	Exhaust pipe
5	Washer
6	Bolt
7	Nut
8	Washer

8、 Lubricating system

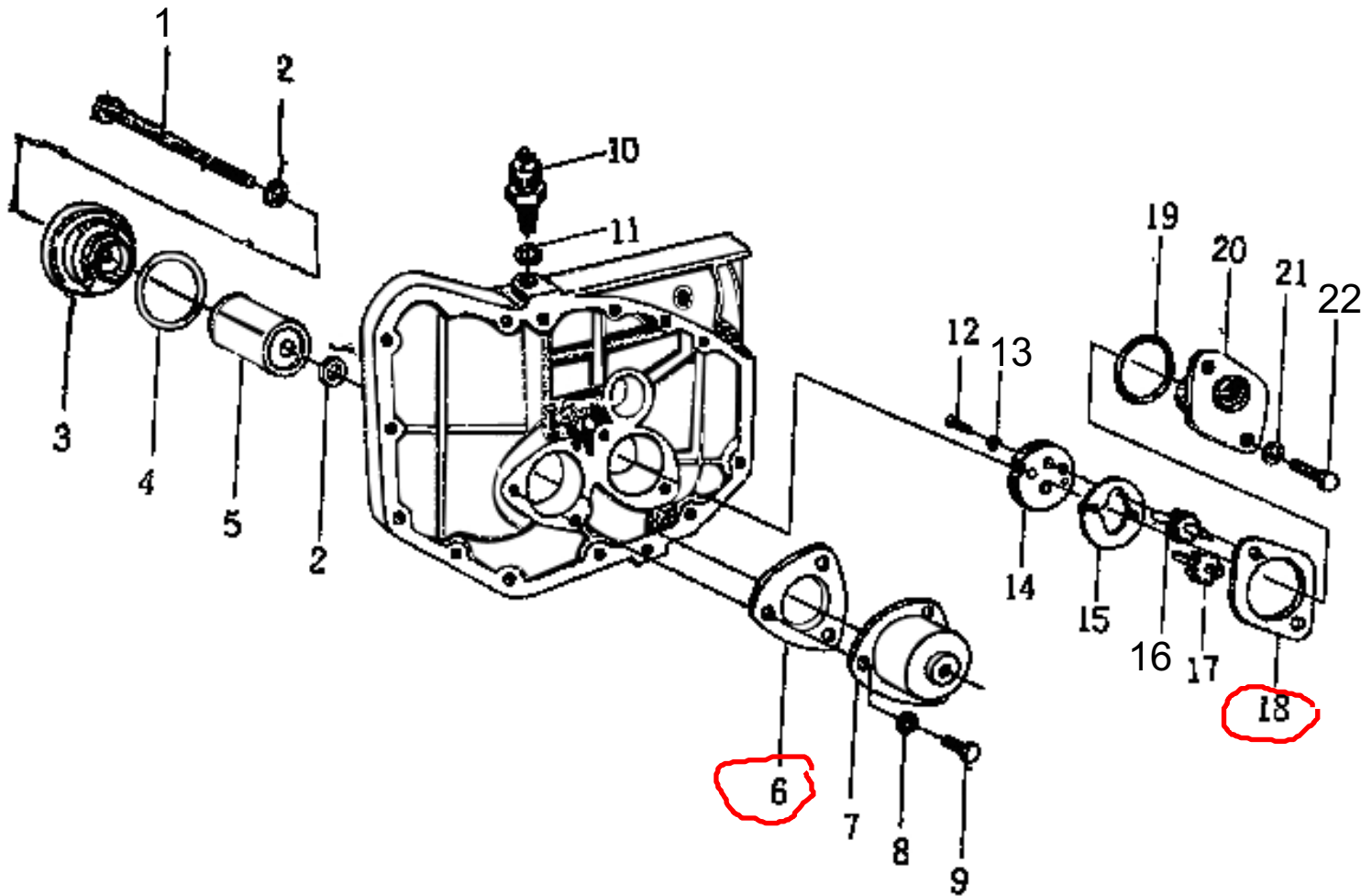

8、 Lubricating system

No.	Parts name
1	Bolt
2	Washer
3	Oil filter body
4	O Ring 50x3.1
5	Oil filter assembly
6	Washer
7	Filter cap and base bolt
8	Washer
9	Bolt
10	Oil indicator
11	Indicator washer
12	Screw
13	Washer
14	Oil pump cover
15	Oil pump cover washer
16	Oil pump gear
17	Oil pump driven gear
18	Oil pump washer
19	Oil pump O ring
20	Oil pump
21	Washer
22	Bolt

9、 Fuel system

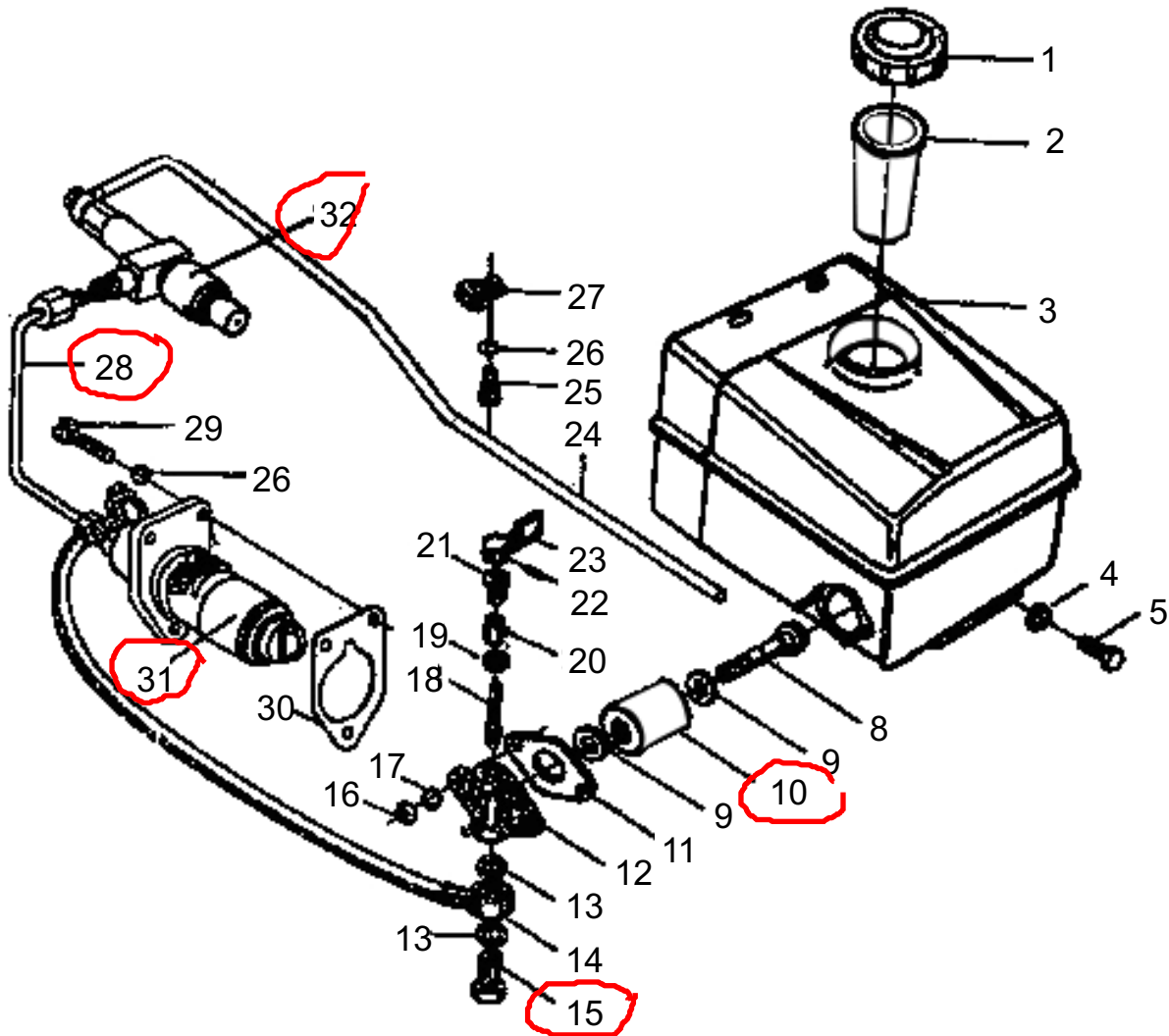

9、 Fuel system

No.	Parts name	No.	Parts name
1	Diesel fuel tank cover	18	Switch element
2	Oil filter	19	Sealing ring
3	Diesel fuel tank solder parts	20	Bushing
4	Washer	21	Screw cap
5	Bolt	22	Pin
8	Bolt	23	Switch handle
9	O ring	24	Oil return pipe
10	Oil filter core	25	Bolt
11	Washer	26	Washer
12	Fuel tank switch	27	Oil return pipe clip
13	Washer	28	High pressure oil pipe
14	Oil pipeline	29	Bolt
15	Inlet joint	30	Oil pump adjusting washer
16	Nut	31	Fuel injection pump
17	Washer	32	injector

10、Governor and control system

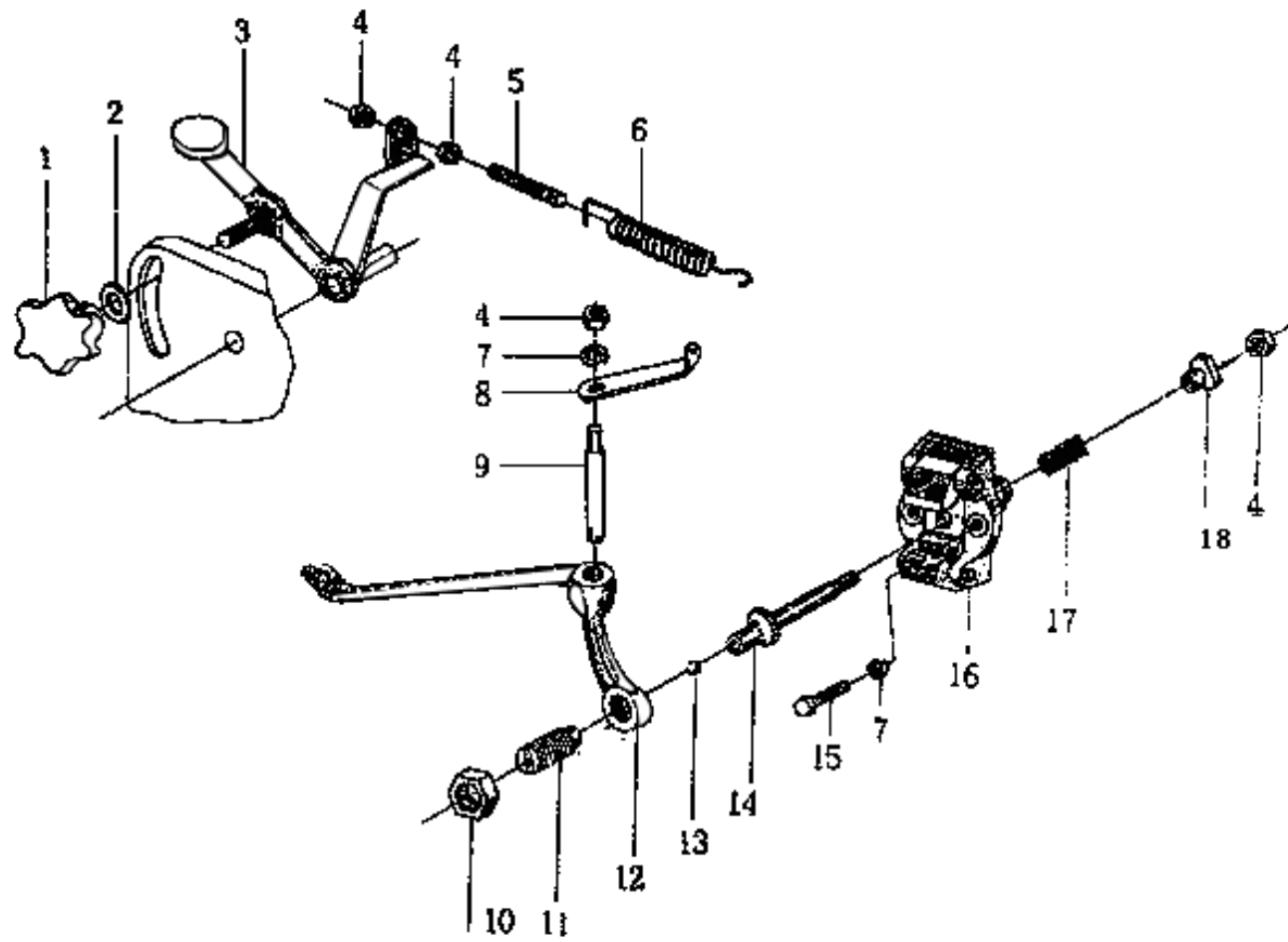

10、Governor and control system

No.	Parts name
1	Handle
2	Washer
3	Governor and control handle
4	Nut
5	Adjusting screw
6	Spring
7	Washer
8	Pull rod
9	Lever shaft
10	Small hexagon medium thin nut
11	Adjusting screw
12	Angled lever
13	Steel ball
14	Speed control shaft 5/16"
15	Bolt M6×18
16	Fly hammer bracket
17	Speed regulation tension spring
18	Spring base

11. Fuel injection pump assembly

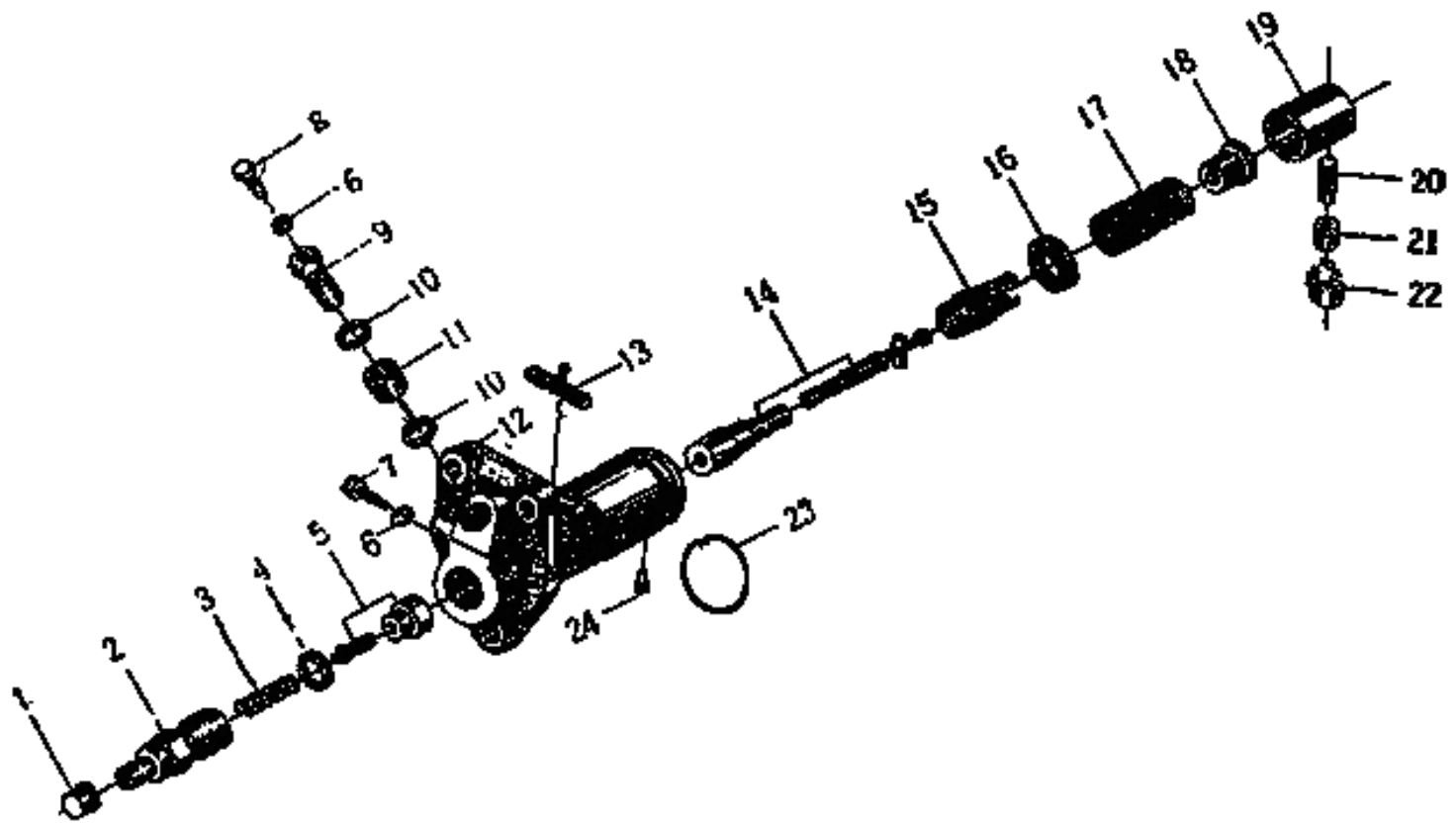

11、 Fuel injection pump assembly

No.	Parts name
1	Dirt-proof screw cap
2	Injection valve nut
3	Injection valve spring
4	Injection valve washer
5	Injection valve element
6	Washer
7	Barrel locating screw
8	Vent screw
9	Intake pipe screw
10	Washer
11	Dirt-proof ring
12	Pump body
13	Gear rod
14	Piston part
15	Adjusting gear ring
16	Spring base (upper)
17	Piston spring
18	Spring base (down)
19	Push rod
20	Wheel pin
21	Wheel pin bushing
22	Idler wheel
23	Circlip
24	Guide pin

12. Injector assembly

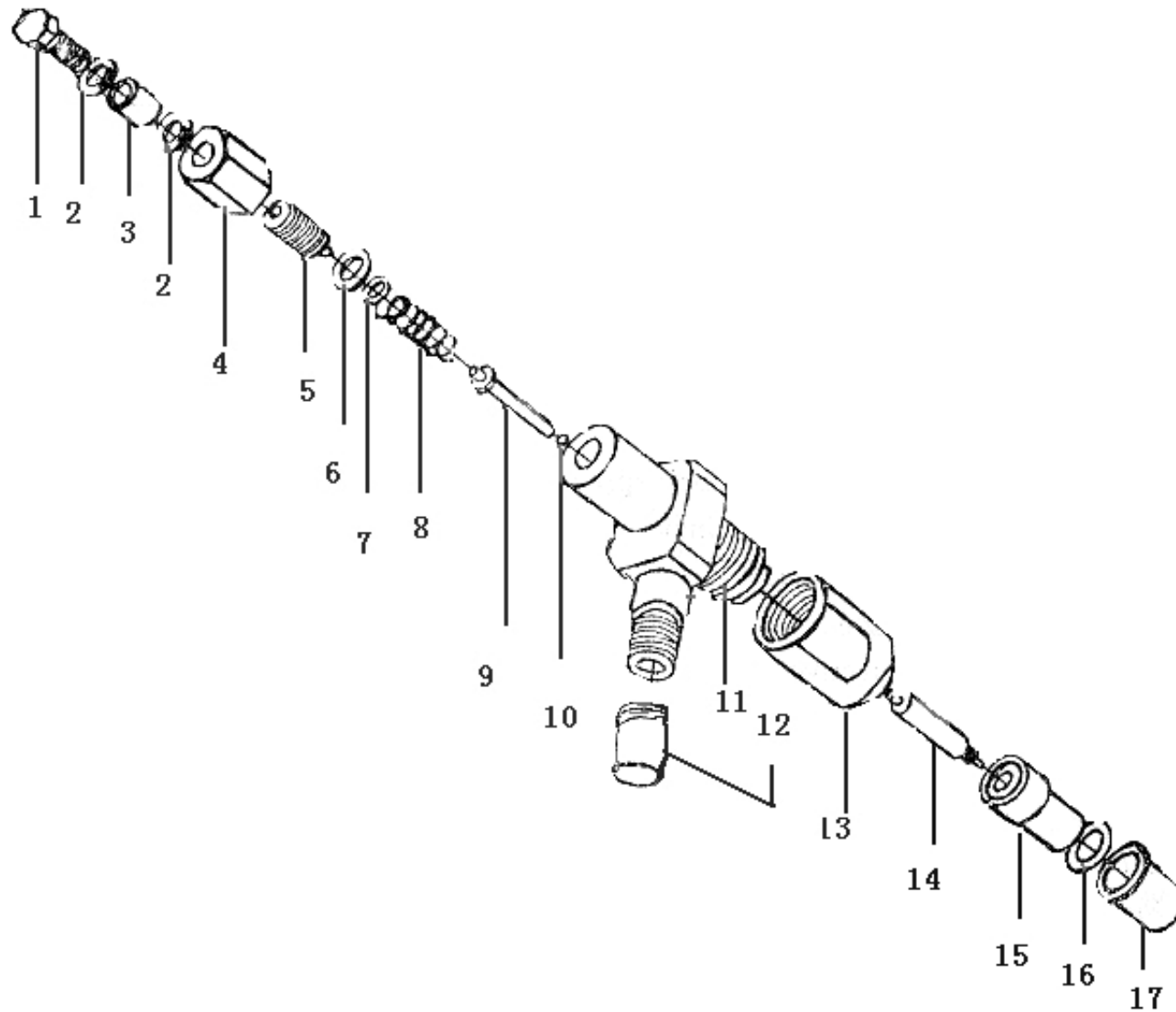

12、 Injector assembly

No.	Parts name
1	Oil return joint
2	Washer
3	Dirt-proof washer
4	Nut
5	Pressure adjusting screw
6	Washer
7	Washer
8	Pressure adjusting washer
9	Apical body
10	Steel ball1/8"
11	Injector
12	Dirt-proof screw cap
13	Oil injection nuzzle nut
14	Needle valve
15	Needle valve assembly
16	Nuzzle washer
17	Shield

13、 Water cooling system assembly (I)

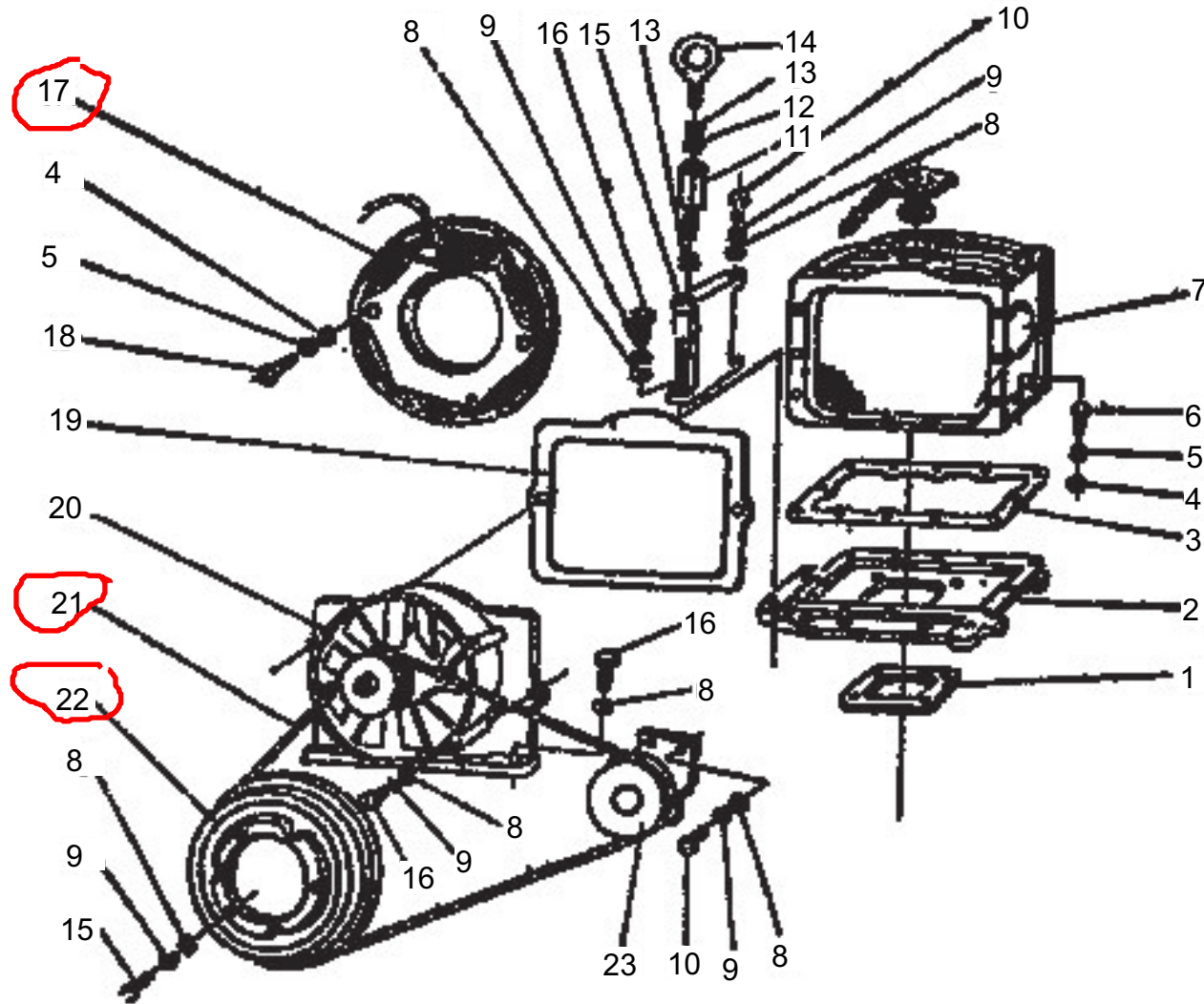

14、Water cooling system assembly (II)

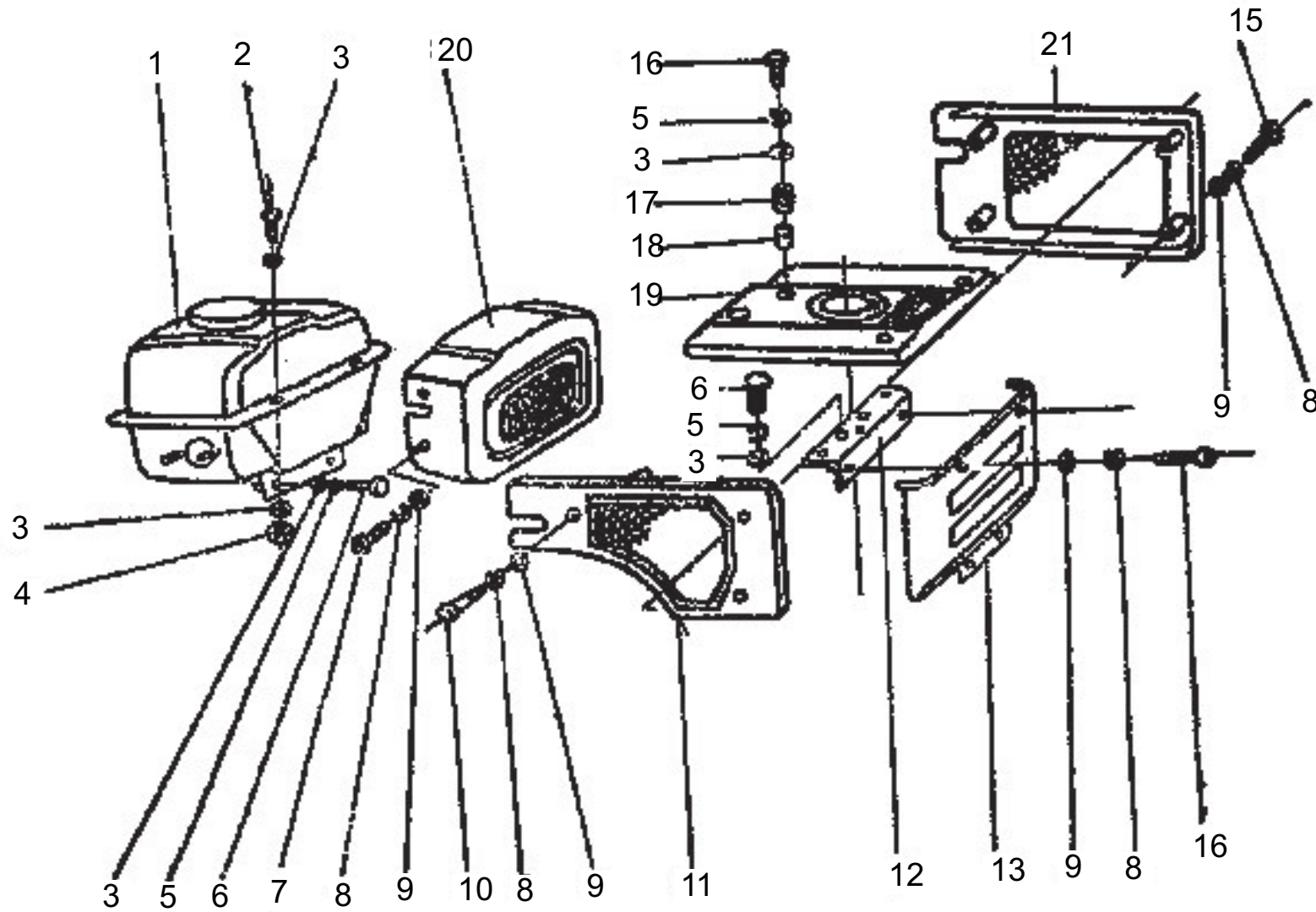

13、Water cooling system assembly (I)

No.	Parts name
1	Water tank washer
2	Base plate
3	Radiator washer
4	Washer GB97.1-85 6
5	Washer GB93-87 6
6	Bolt GB5783-86-M6×20
7	Radiator
8	Washer GB97.1-85 8
9	Washer 93-87 8
10	Bolt GB5783-86-M8×20
11	Connection bolt
12	Washer GB97.1-85 10
13	Washer GB93-87
14	Bolt GB825-88-M10
15	Front bracket of fuel tank
16	Bolt GB5783-86-M8×25
17	Stator of generator
18	Bolt GB67-85-M6×25
19	Airproof gasket
20	Fan
21	Belt for fan
22	Rotor of generator
23	Tension wheel

14、Water cooling system assembly (II)

No.	Parts name
1	Fuel tank solder parts
2	Bolt GB5783-86-M8×20
3	Washer GB97.1-85 8
4	Nut GB6170-86-M8
5	Washer GB93-87 8
6	Bolt GB5783-86-M8×16
7	Bolt GB67-85 6
8	Washer GB93-87 6
9	Washer GB 97.1-85 6
10	Bolt GB5783-86-M6×50
11	Fan cover solder part
12	Cover frame solder part
13	Decorative board
14	Bolt GB5783-86-M6×12
15	Bolt GB5783-86-M6×35
16	Bolt GB5783-86-M8×25
17	Anti-shock washer
18	Bushing
19	Cover board
20	Floodlight 12V/21W
21	Radiator cover solder part

15、 . flywheel generator assembly (only for EN DT-8807)

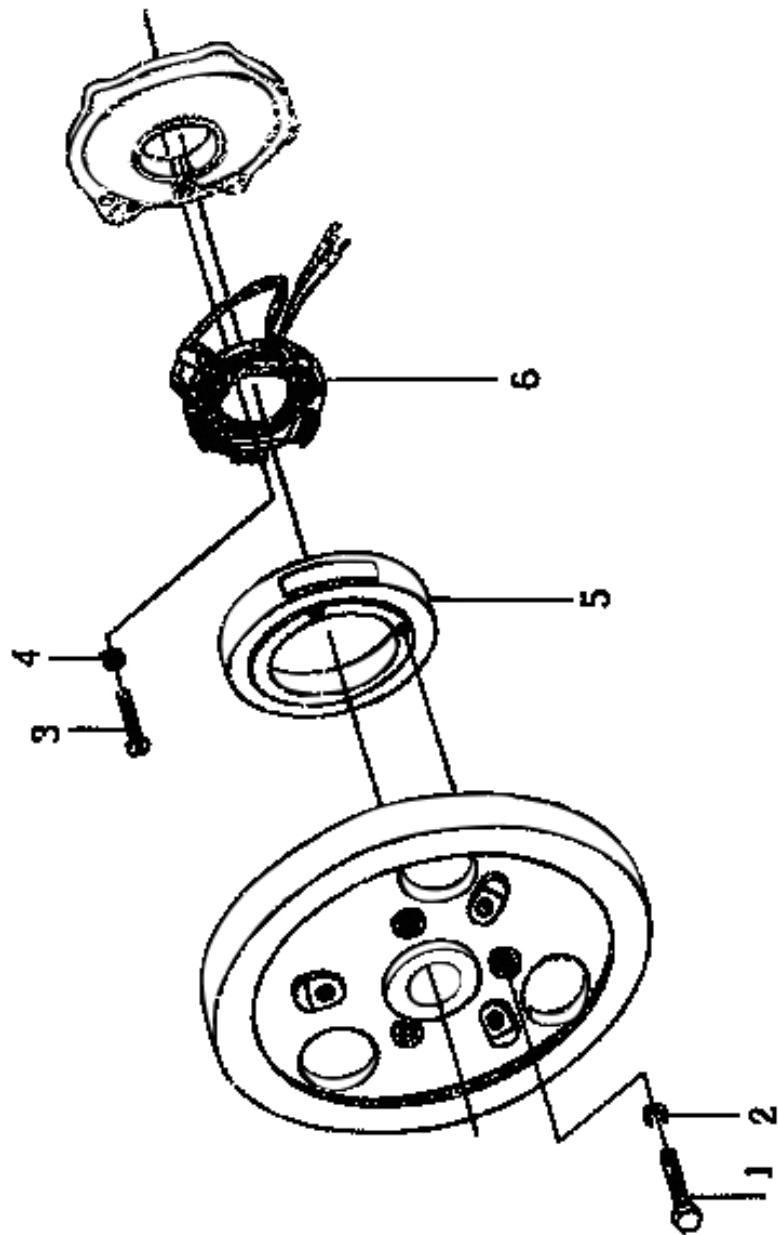

15. flywheel generator assembly

No.	Parts name
1	Bolt
2	Washer
3	Screw
4	Washer
5	Rotor assembly
6	Stator assembly

16. Starter handle assembly

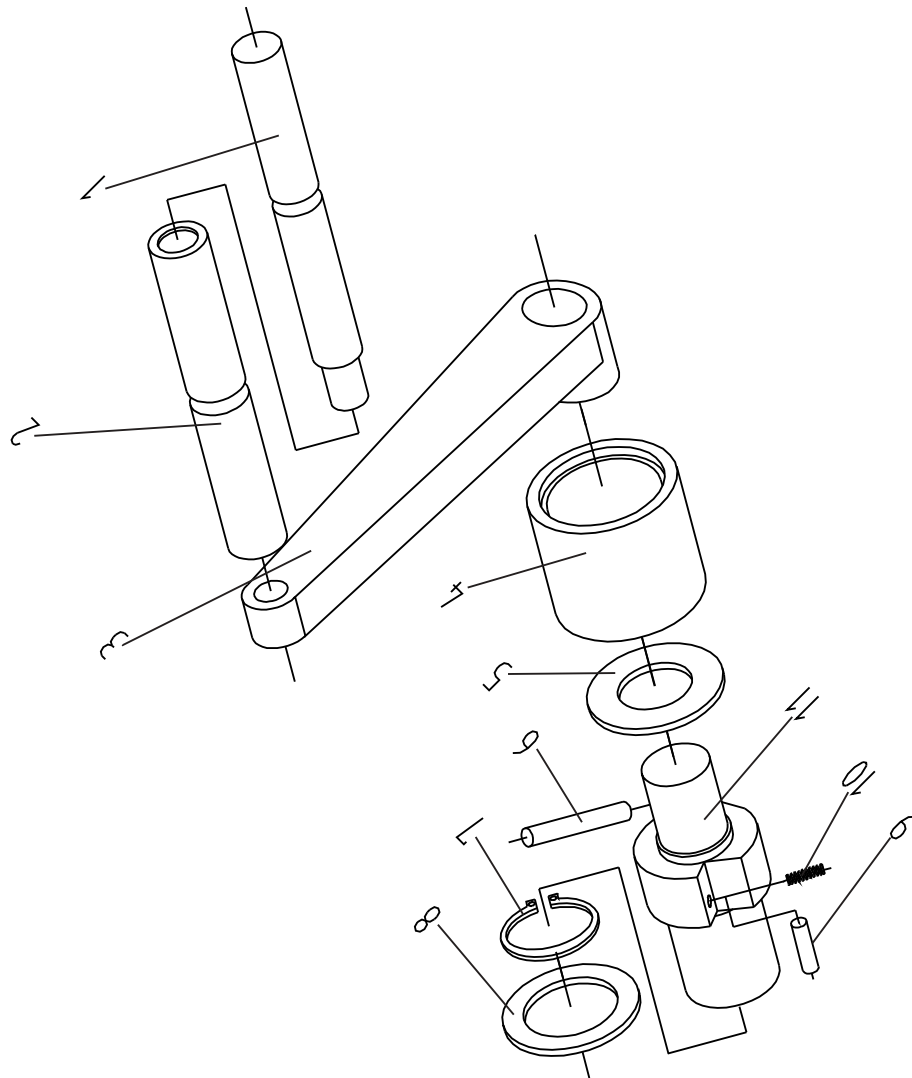

16. Starter handle assembly

No.	Parts number
1	Handle sleeve
2	Handle
3	Starter crank
4	Starter claw
5	Rear retaining ring
6	Starter claw pin
7	Retaining ring 30
8	Front retaining ring
9	Column pin
10	Spring
11	Brake ratchet