

PARTS CATALOGUE FOR ENGINE

DT-8809X

ДТ-8809Э

VERSION No. : 20120606-01

1、 Engine body Assembly

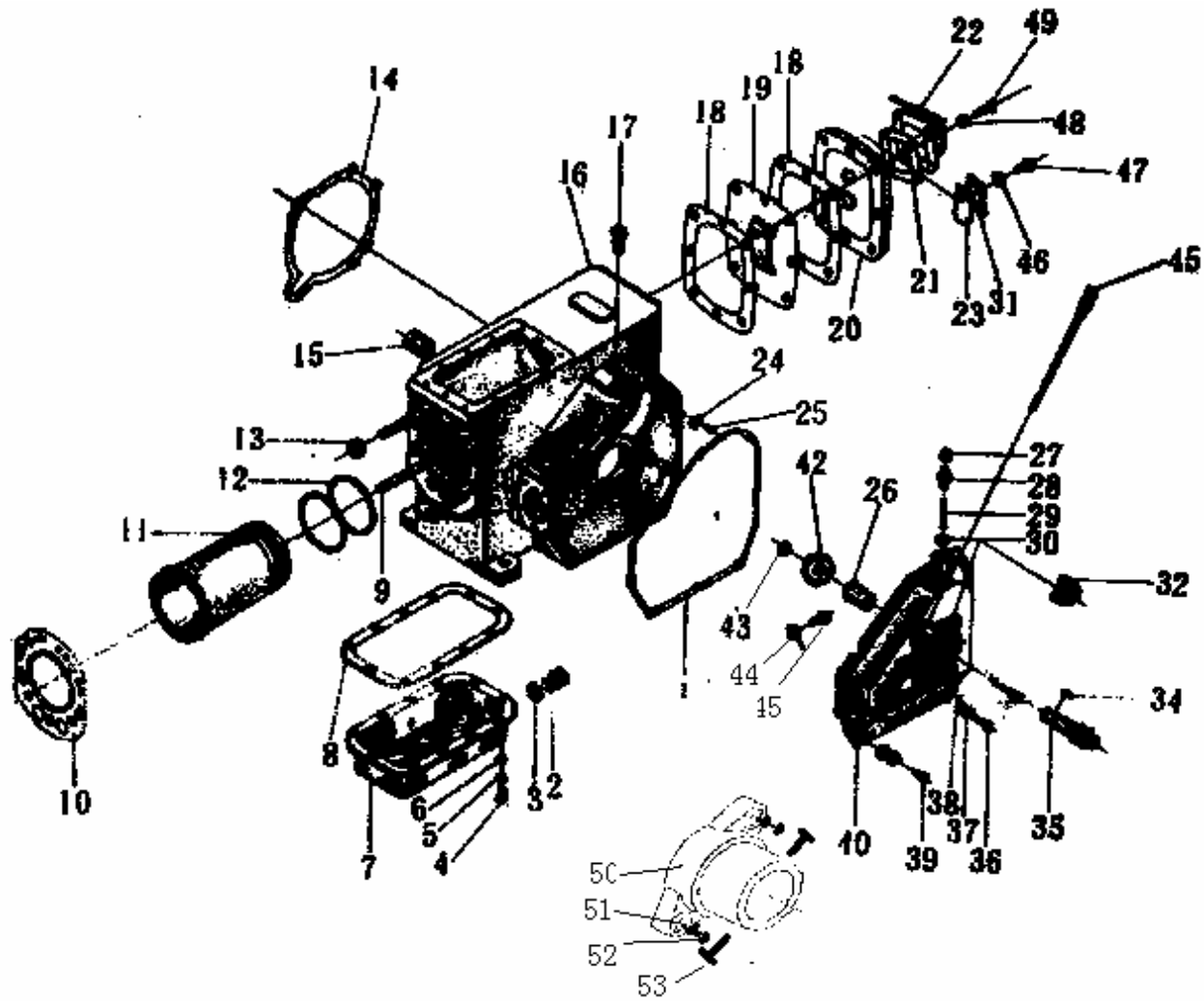

1、 Engine body Assembly

No.	Parts name	No.	Parts name
1	Timing gear cover gasket	15	Balance axis bear
2	Bolt plug	16	Unit body
3	Washer	17	sleeve
4	washerM8×16	18	Respirator gasket
5	Washer 8	19	Respirator inner partition board
6	Washer 8	20	Respirator solder part
7	oil sump unit	21	washer
8	Oil sump gasket	22	Respirator inner component
9	Cylinder cover double head bolt	23	Breathing piece
10	Cylinder head washer	24	O seal ring
11	Cylinder sleeve	25	Sleeve
12	Cylinder cover water sealing	26	Starter shaft bushing
13	Cylinder head nut	27	Indicator cap
14	gasket	28	Indicator base

No.	Parts name	No.	Parts name
29	Indicator pin	44	Washer 6
30	washer	46	Screw M4x8
31	Respirator press board	47	Nut M4
32	Oil ruler	48	Screw M5x10
33	Key 5x16	49	Washer 5
34	Starter shaft	50	Brake base
35	Bolt M6x30	51	Bolt M6x25
36	Washer 6	52	Washer 6
37	Washer 6	53	Bolt M8x20
38	Bolt M6x25		
39	Timing start gear		
40	Timing gear case cover		
41	Back washer 20		
42	Washer 5		
43	Screw M5x10		

2. Water cooling system assembly

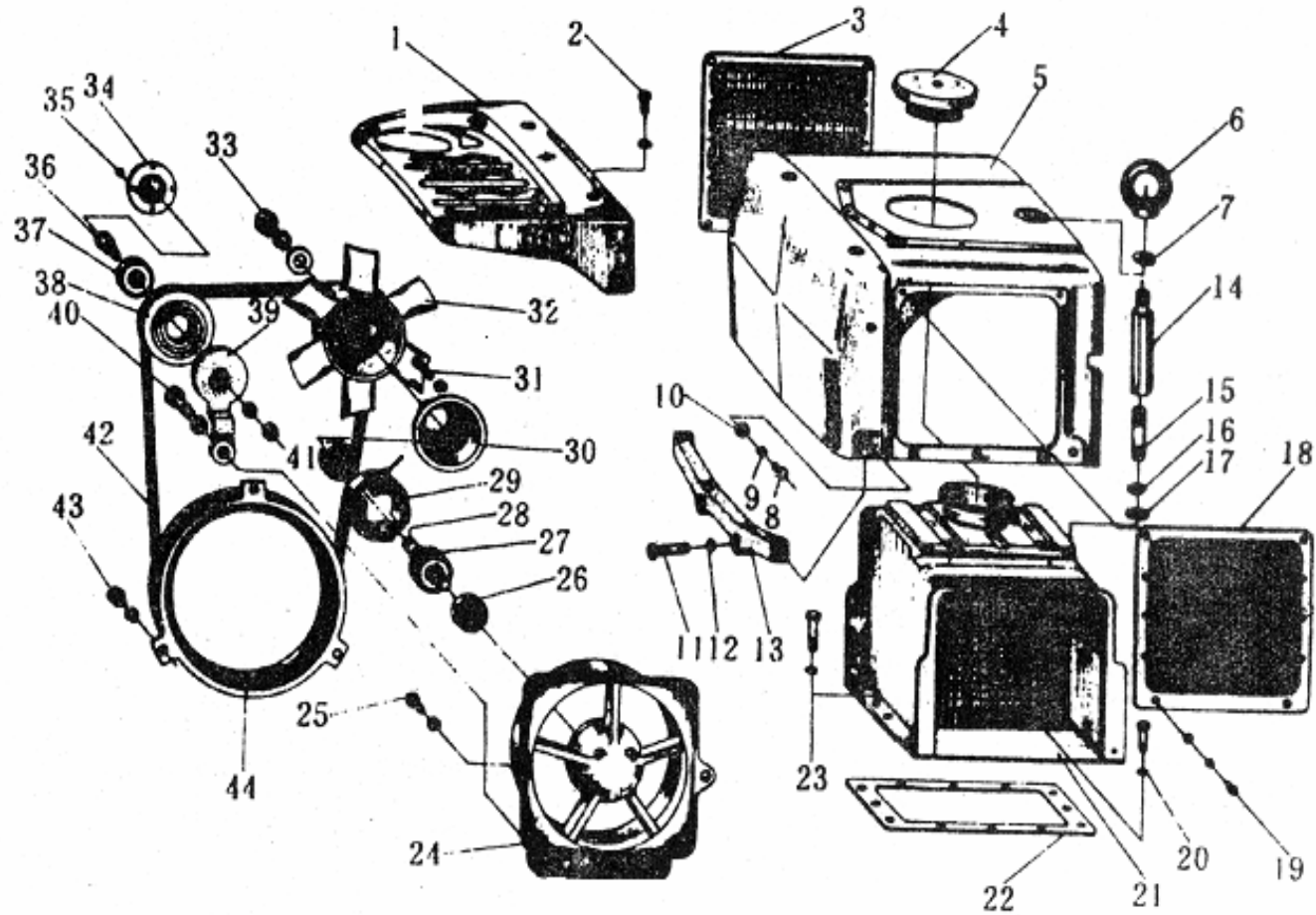

2、 Water cooling system assembly

No.	Parts name	No.	Parts name
1	Cover	14	Hook screw rod
2	Bolt M6×12	15	Bolt AM12×120
	Washer 6	16	Washer 12
3	back dustproof cover	17	Washer 12
4	Radiator cap	18	Front dustproof cover
5	Radiator outer cover	19	Bolt M4×10
6	hook		Washer 4
7	Washer 12		Washer 4
8	Washer 6	20	Boot M6×20
9	Bolt M6×20		Washer 6
10	Washer 6	21	Radiator component
11	Bolt M8×30	22	Radiator gasket
12	Washer 8	23	Bolt M8×20
13	Radiator outer cover support		Washer 8

No.	Parts name	No	Parts name
24	Fan base	35	Screw M4×6
25	Boot M8×25	36	Tension wheel shaft
26	Bearing 6201	37	Bearing 6201
27	rotor	39	Tension wheel supporter
28	Pin B3×8	40	Bolt M10×40
29	stator	41	Nut M8
30	supporter	42	Belt for fan
31	Screw M6×55	43	Bolt M8×20
	Washer 6		Washer 8
32	Fan	44	Belt wheel
33	Nut M12		
	Washer 12		
	Washer 12		

3、Cylinder head Assembly

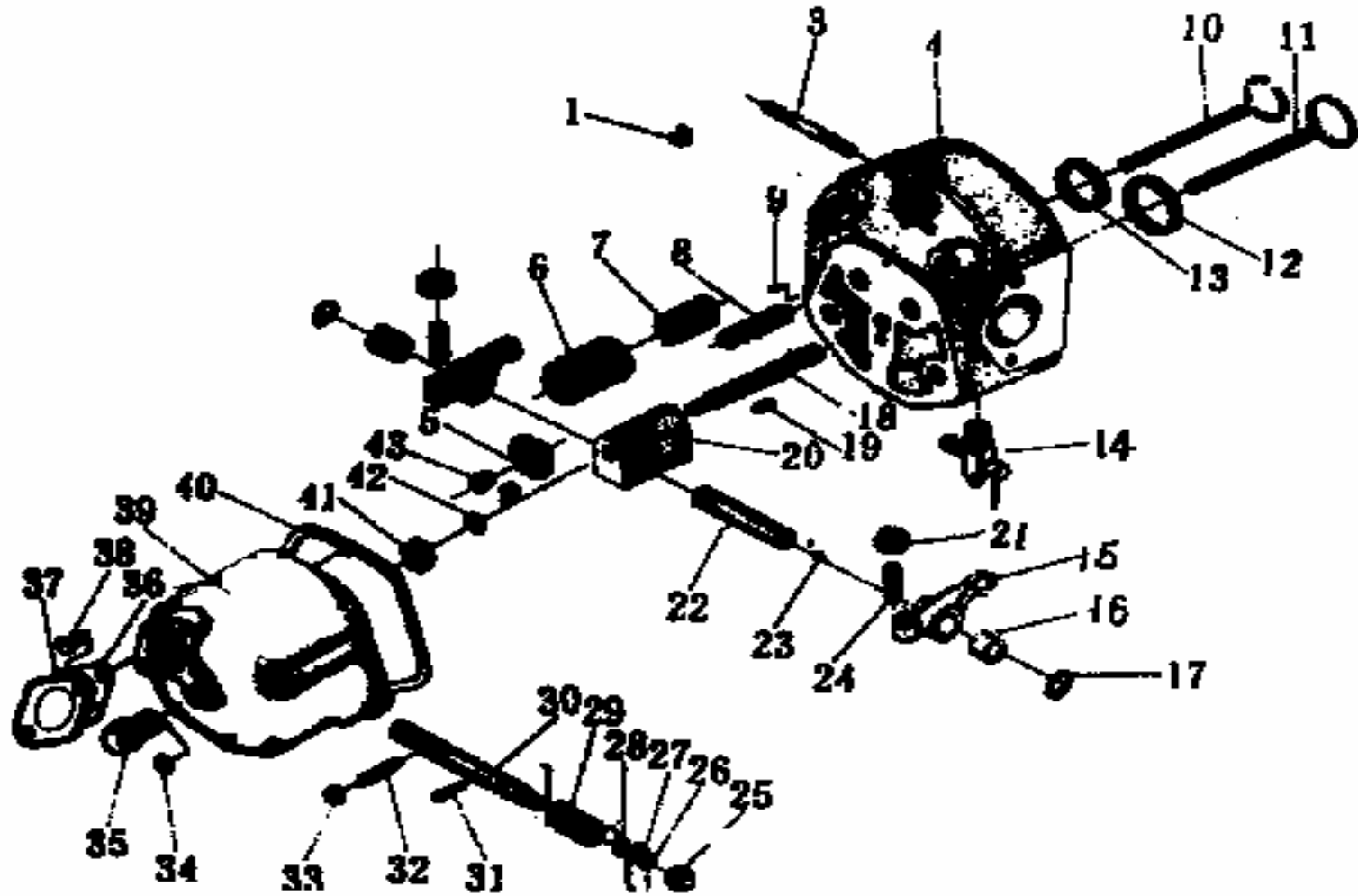

3、Cylinder head Assembly

No.	Parts name	No.	Parts name	No.	Parts name
1	Nut M8	16	Valve rockshaft bush	31	Pin 3.2×16
3	Bolt M8×65	17	Washer 14	32	Adjust nut
4	Cylinder head	18	Bolt	33	Nut M6
5	Valve spring seat (upper)	19	Retainer pin	34	Seal ring
6	Bit valve spring	20	Rockshaft base	35	nut
7	Small valve spring	21	Nut M10×1	36	pad
8	Valve guide	22	Rocker shaft	37	cap
9	Pin B3×8	24	Adjust nut	38	Bolt M×12
10	Exhaust valve	25	Nut M8	39	Cylinder head cover
11	Intake valve	26	Washer 8	40	Gasket of cylinder head cover
12	Intake valve base	27	Pressure-reducing handle	41	Nut M10
13	Exhaust valve base	28	Seal ring 12×1.9	42	washer
14	Discharge water valve	29	Pressure-reducing shaft spring	43	Valve cotter
15	Valve rockshaft	30	Pressure-reducing shaft		

4、Piston and connecting rod assembly

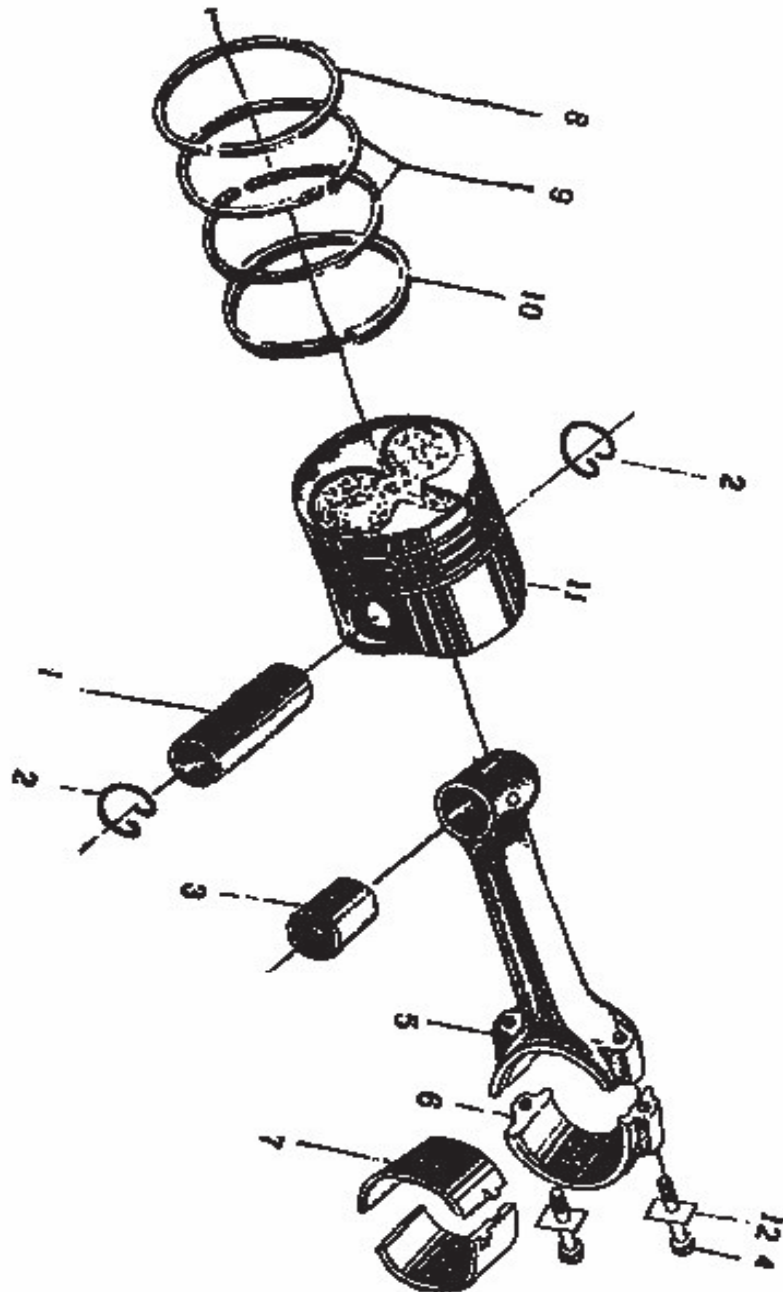

4、Piston and connecting rod assembly

No.	Parts name
1	Piston pin
2	Piston pin retaining ring
3	Connecting rod bushing
4	Connecting rod bolt
5	Connecting rod
6	Connecting rod cover
7	Connecting rod bearing shell
8	First gaseous ring
9	Second, third gaseous ring
10	Oil ring assembly
11	Piston
12	Connecting rod bolt safety plate

5. Crankshaft and flywheel assembly

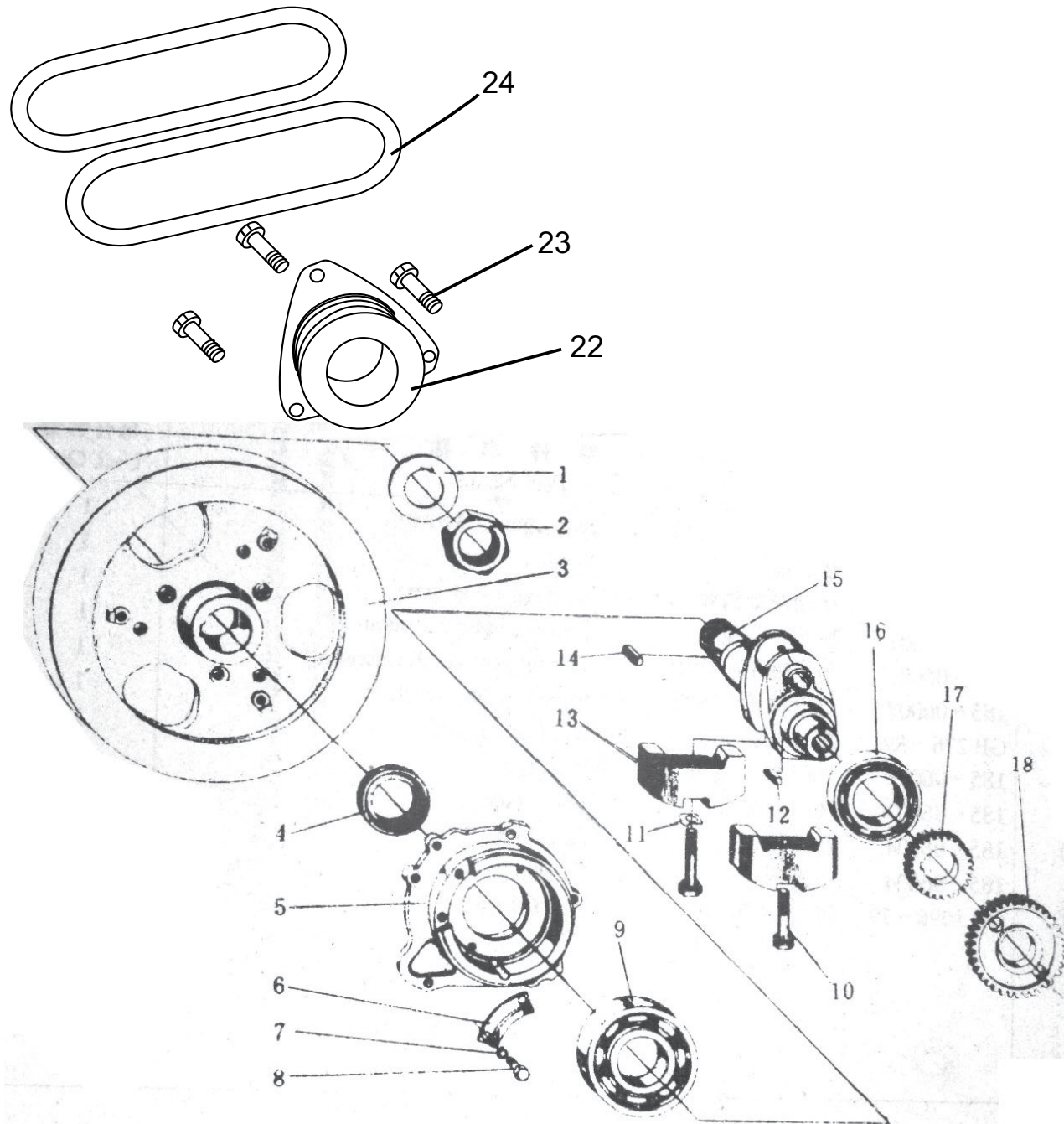

5、Crankshaft and flywheel assembly

No.	Parts name	No.	Parts name
1	Thrust washer	12	Key C8×28
2	Fly wheel nut	13	Balance weight
3	Fly wheel	14	Flat key of flywheel
4	Oil sealing	15	Crank shaft
5	Crankshaft bearing cover	16	Bearing NF211
6	Press board	17	Crankshaft timing gear
7	Washer 6	18	Crankshaft balance gear
8	Bolt M6×16	22	Pulley wheel
9	Bearing 6311	23	Bolt
10	Screw of Balance weight	24	Belt B1800
11	Thrust washer		

6、 Camshaft assembly

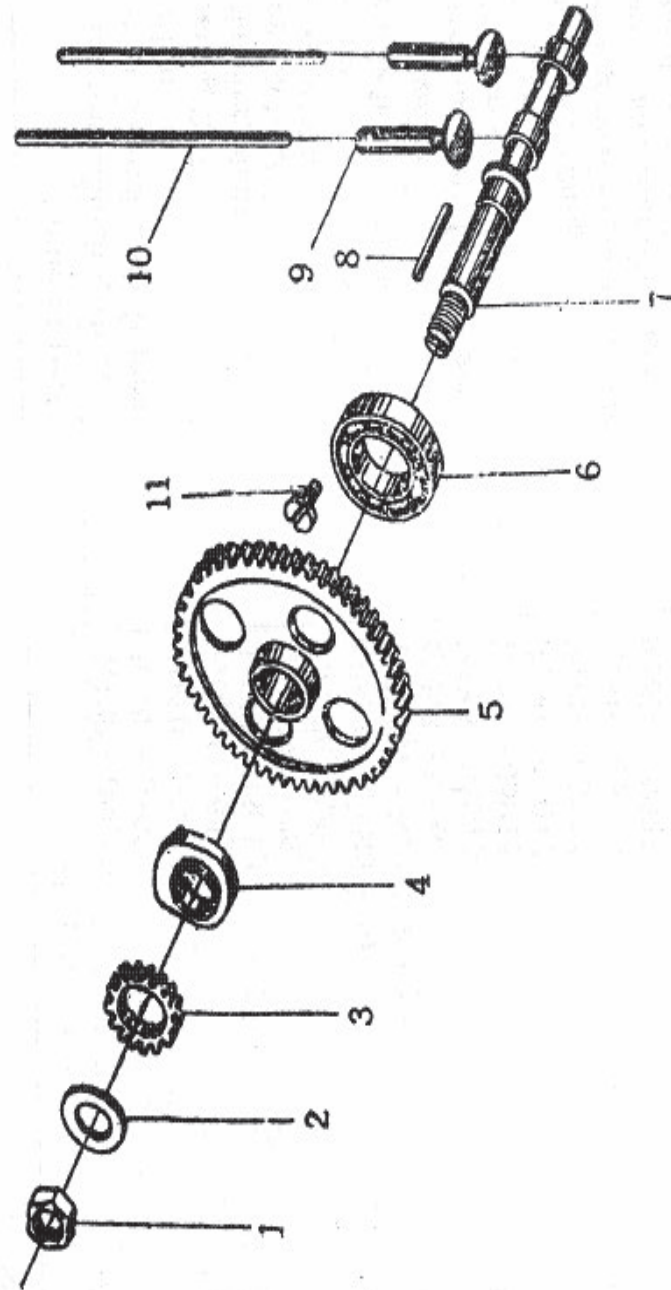

6、 Camshaft assembly

No.	Parts name
1	Nut M18x1.5
2	washer
3	driven starter gear
4	Oil injection pump camshaft
5	Camshaft timing gear
6	bearing 6006
7	Camshaft
8	Key
9	Valve lifer
10	Valve push rod
11	Camshaft thrust screw

7、balance shaft system

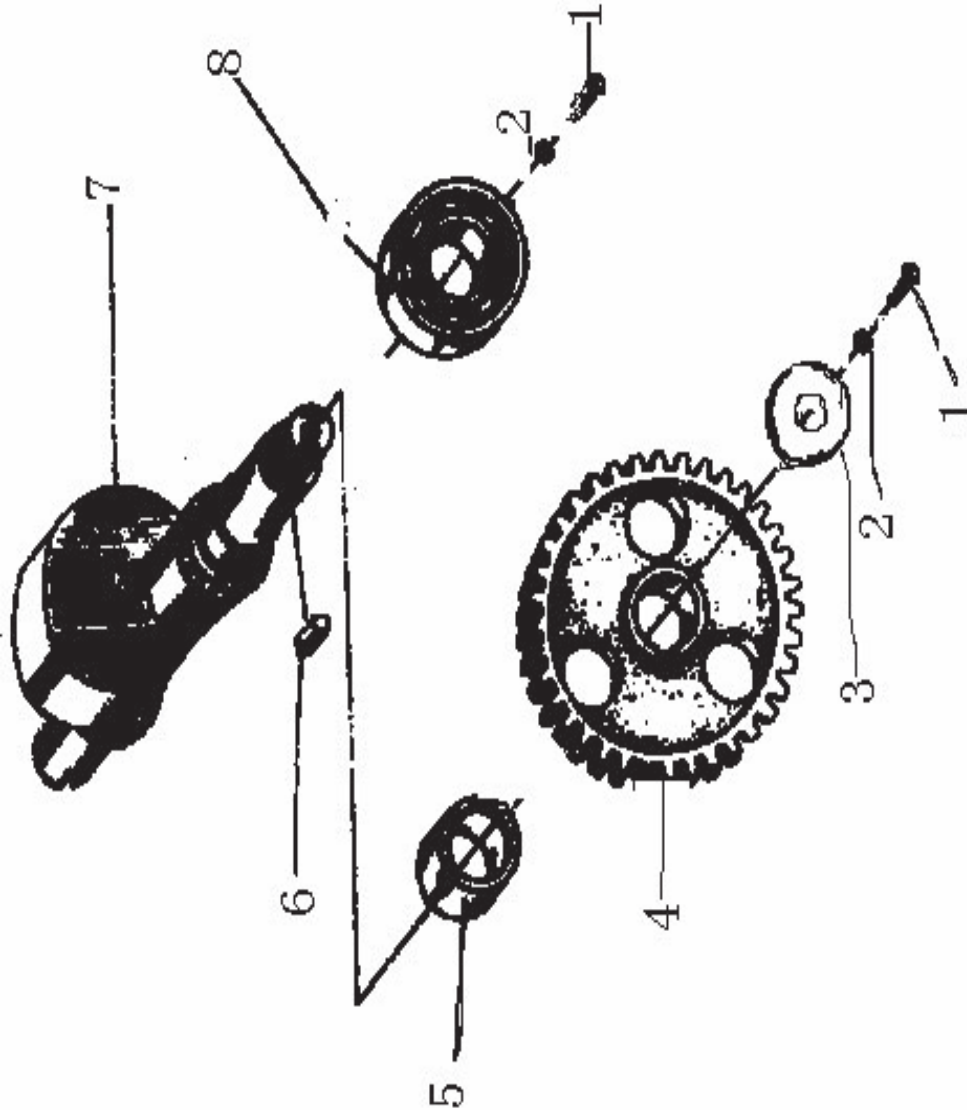

7、balance shaft system

No.	Parts name
1	Bolt M8×20
2	Washer 8
3	Press plate
4	gear
5	bush
6	Key B6×12
7	Balance shaft
8	Bearing 6205

8、 Intake system

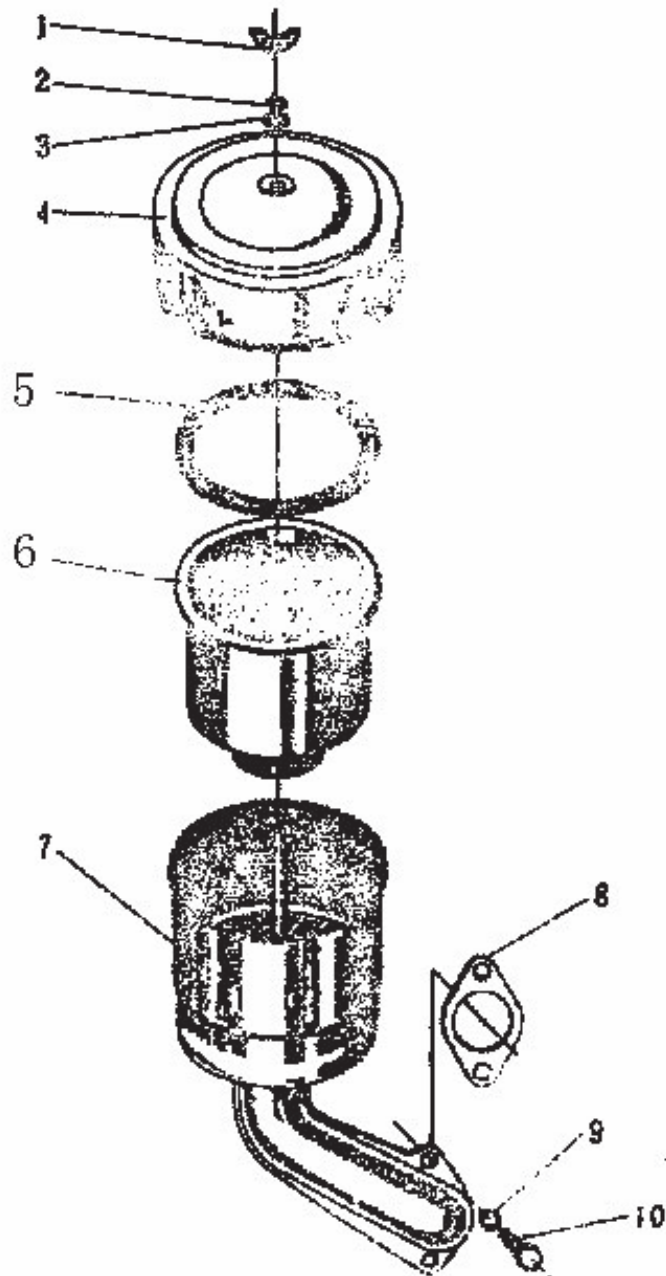

8、 Intake system

No.	Parts name
1	butterfly nut
2	Washer 6
3	Washer 6
4	Filter housing (upper)
5	Sealing ring
6	Filter element
7	Filter outer housing
8	washer
9	Bolt M × 20
10	Washer 8

9、 Exhaust system

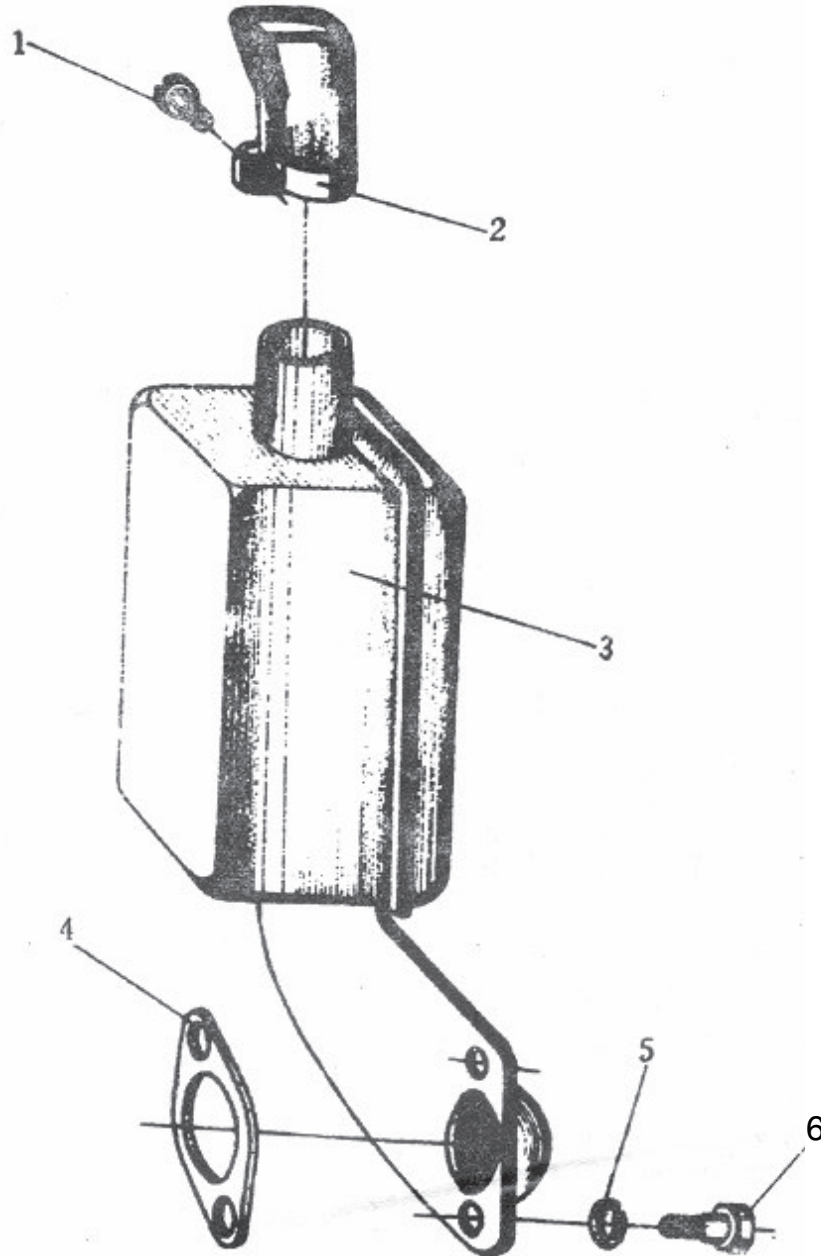

9、 Exhaust system

No.	Parts name
1	Bolt M6×12
2	upper discharge pipe
3	Muffler solder part
4	gasket
5	Washer 8
6	Bolt M8×20

10、 Lubricating system

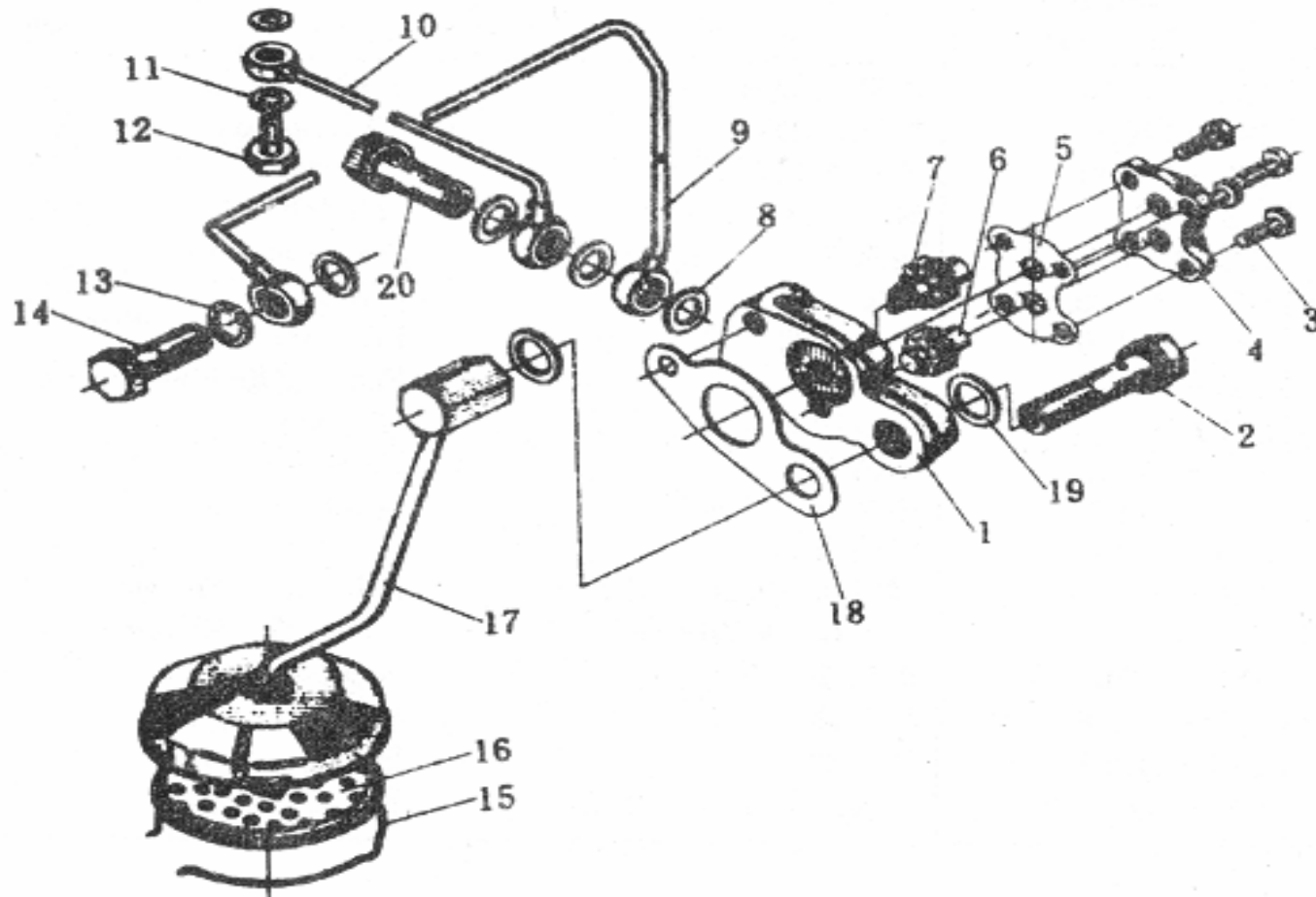

10、 Lubricating system

No.	Parts name	No.	Parts name
1	Oil pump	11	washer
2	hollow bolt	12	connector
3	Bolt M6×16	13	washer
4	Oil pump cover	14	Hollow bolt
5	Gasket of oil pump cover	15	circlip
6	Oil pump driven gear	16	Oil filter body
7	Oil pump gear	17	suck oil plate
8	washeer	18	Gasket of oil pump
9	Main oil pipe	19	Copper washer
10	Fine oil pipe	20	Short hollow bolt

11、 Fuel system

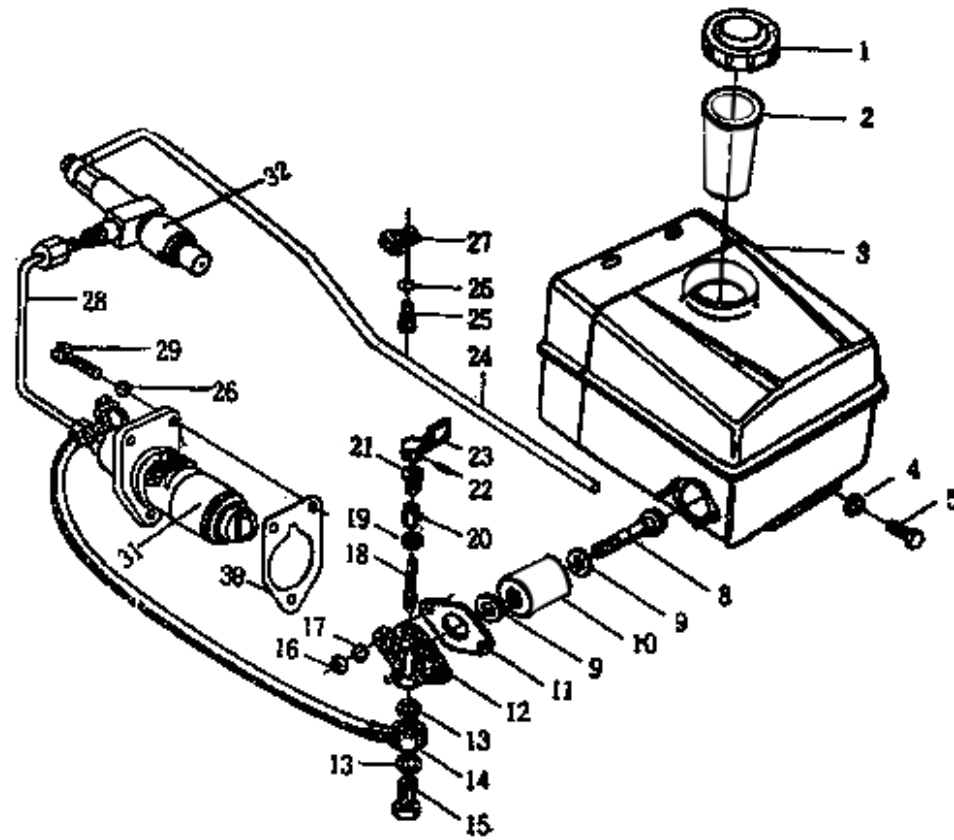

11、 Fuel system

No.	Parts name	No.	Parts name
1	Diesel fuel tank cover	19	Sealing ring
2	Oil filter	20	Bushing
3	Diesel fuel tank solder parts	21	Screw cap
4	Washer	22	Pin
5	Bolt	23	Switch handle
8	Bolt	24	Oil return pipe
9	O ring	25	Bolt
10	Oil filter core	26	Washer
11	Washer	27	Oil return pipe clip
12	Fuel tank switch	28	High pressure oil pipe
13	Washer	29	Bolt
14	Oil pipeline	30	Oil pump adjusting washer
15	Inlet joint	31	Fuel injection pump
16	Nut	32	Fuel Injector
17	Washer		
18	Switch element		

12、Governor and control system

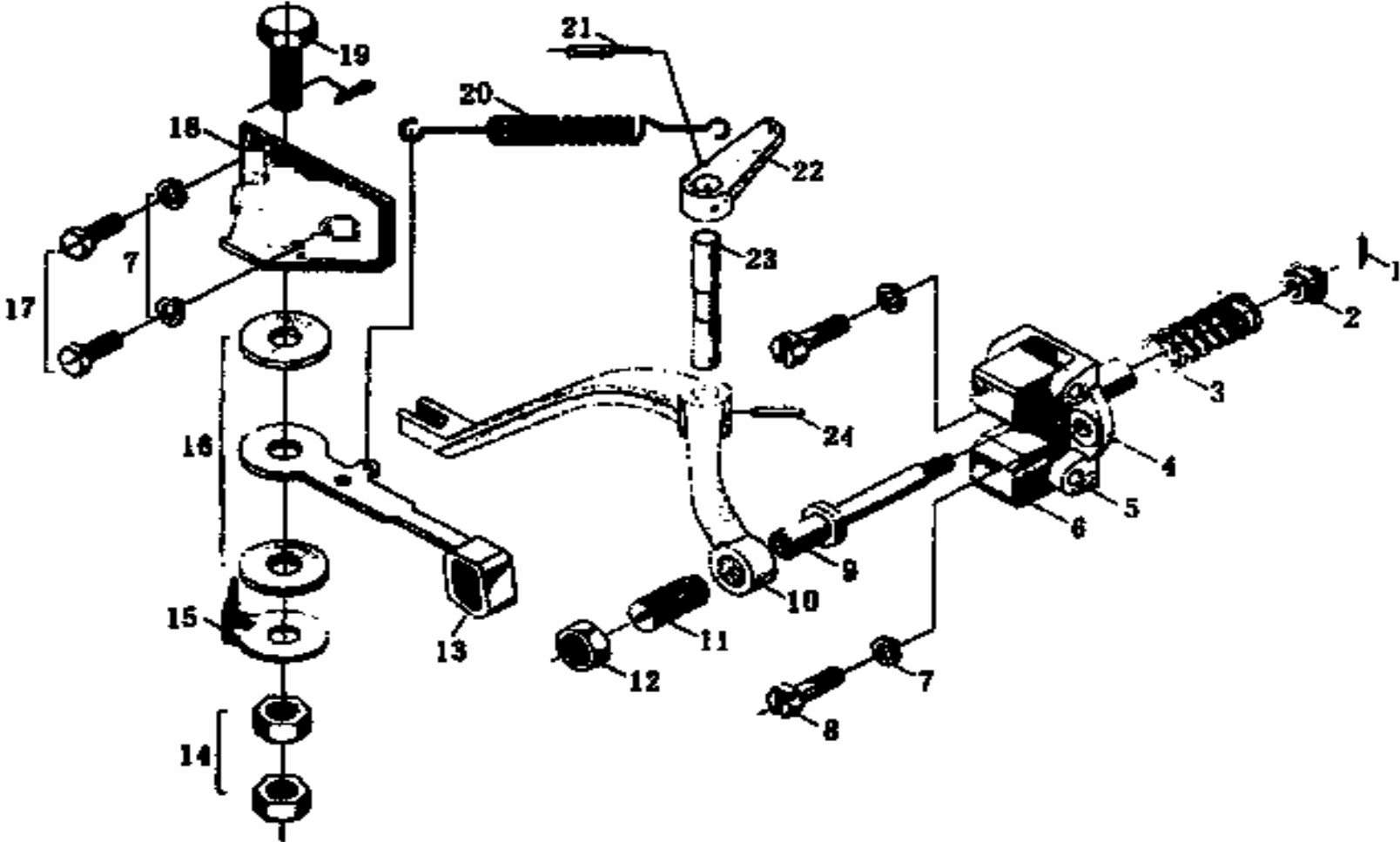

12、 Governor and control system

No.	Parts name	No.	Parts name
1	Pin 1.6×12	14	Nut M10
2	Adjusting speed spring seat	15	Press plate
3	Adjusting speed spring	16	friction plate
4	Fly hammer supporter	17	Bolt M6×16
5	pin of fly hammer	18	fixation board
6	fly hammer	19	Bolt M10×35
7	washer6		Pin 2×16
8	bolt	20	Adjusting spring
9	Shaft of adjusting speed	21	Pin A3×30
10	angle lever	22	Draw pole
11	Adjusting screw	23	adjusting lever axis
12	Bolt M12×1.25	24	Pin A3×20
13	control handle		

13、 Fuel injection pump assembly

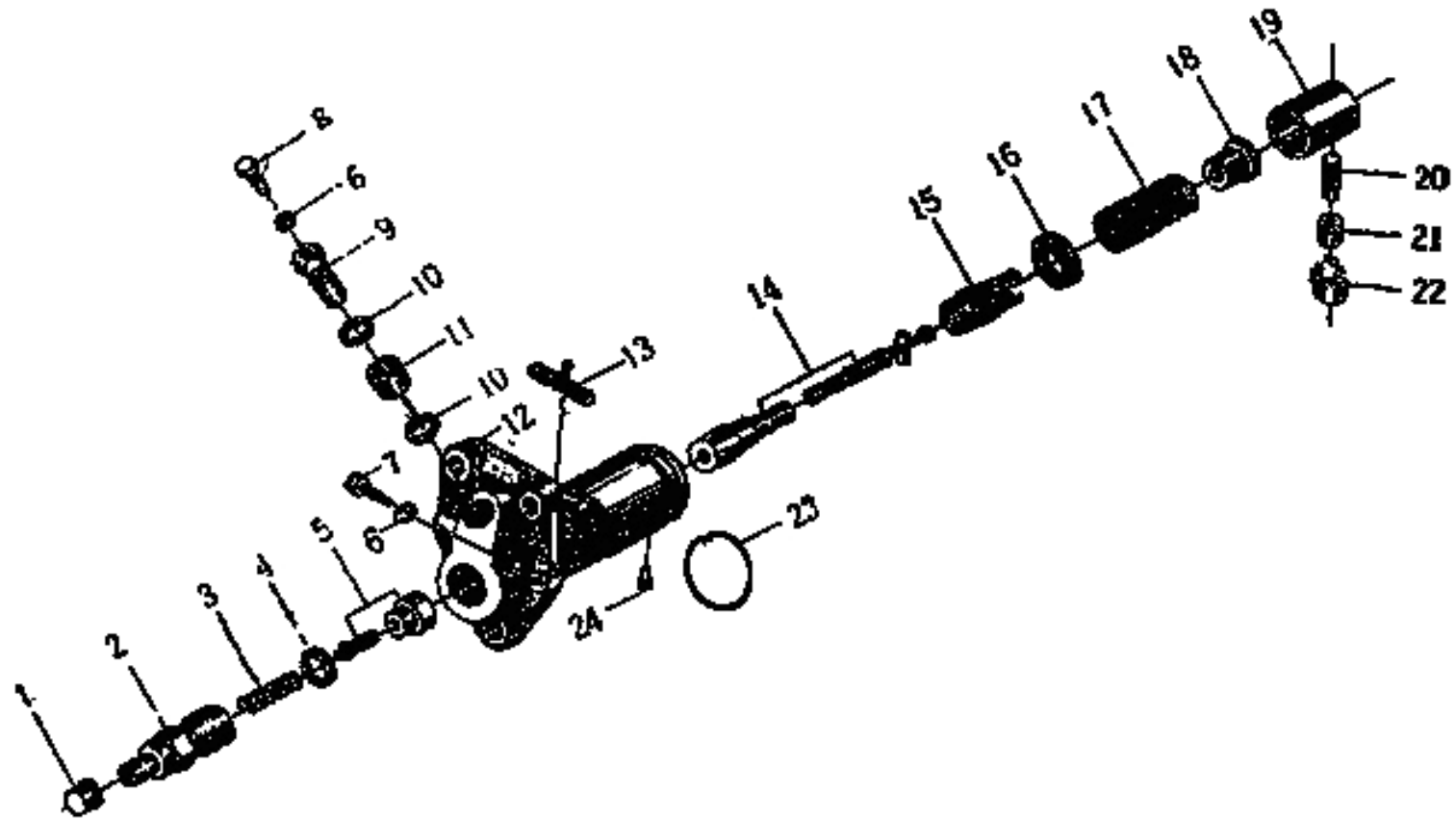

13、 Fuel injection pump assembly

No.	Parts name	No.	Parts name
1	Dirt-proof screw cap	13	Gear rod
2	Injection valve nut	14	Piston part
3	Injection valve spring	15	Adjusting gear ring
4	Injection valve washer	16	Spring base (upper)
5	Injection valve element	17	Piston spring
6	Washer	18	Spring base (down)
7	Barrel locating screw	19	Push rod
8	Vent screw	20	Wheel pin
9	Intake pipe screw	21	Wheel pin bushing
10	Washer	22	Idler wheel
11	Dirt-proof ring	23	Circlip
12	Pump body	24	Guide pin

14、 injector assembly

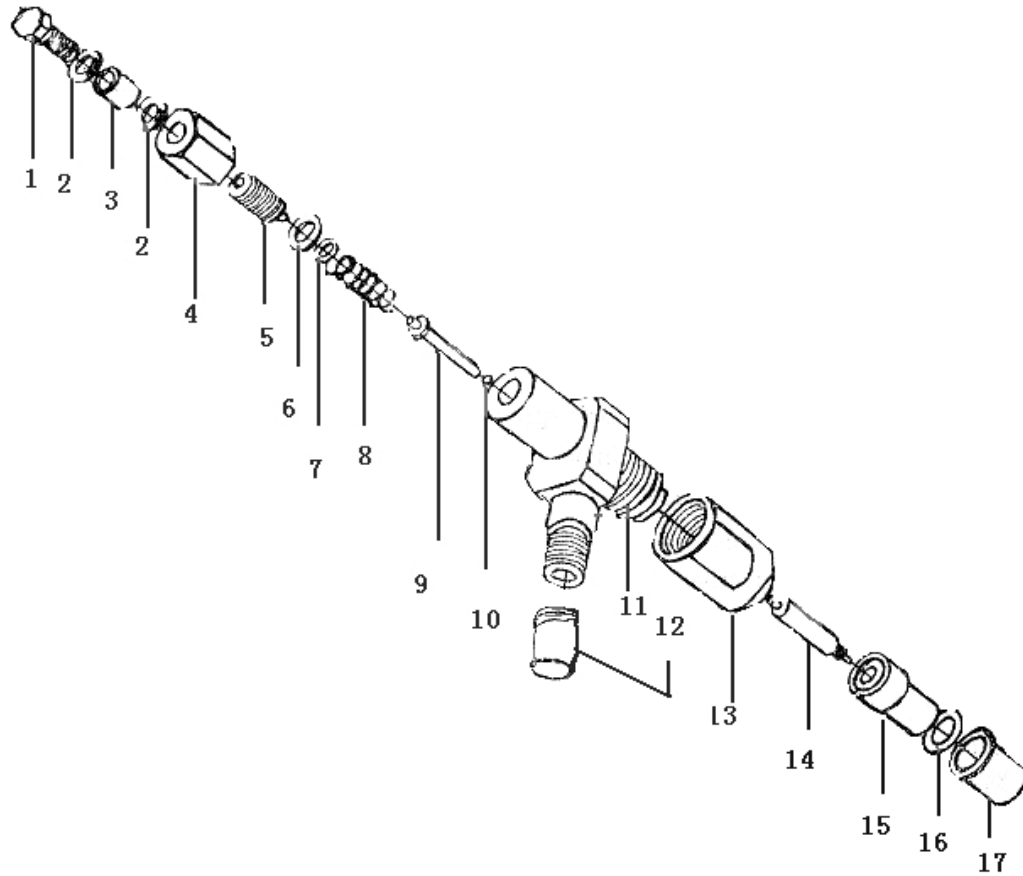

14 、injector assembly

No.	Parts name
1	Oil return joint
2	Washer
3	Dirt-proof washer
4	Nut
5	Pressure adjusting screw
6	Washer
7	Washer
8	Pressure adjusting washer
9	Apical body
10	Steel ball 1/8"
11	Injector
12	Dirt-proof screw cap
13	Oil injection nuzzle nut
14	Needle valve
15	Needle valve assembly
16	Nuzzle washer
17	Shield

15. Starter handle assembly

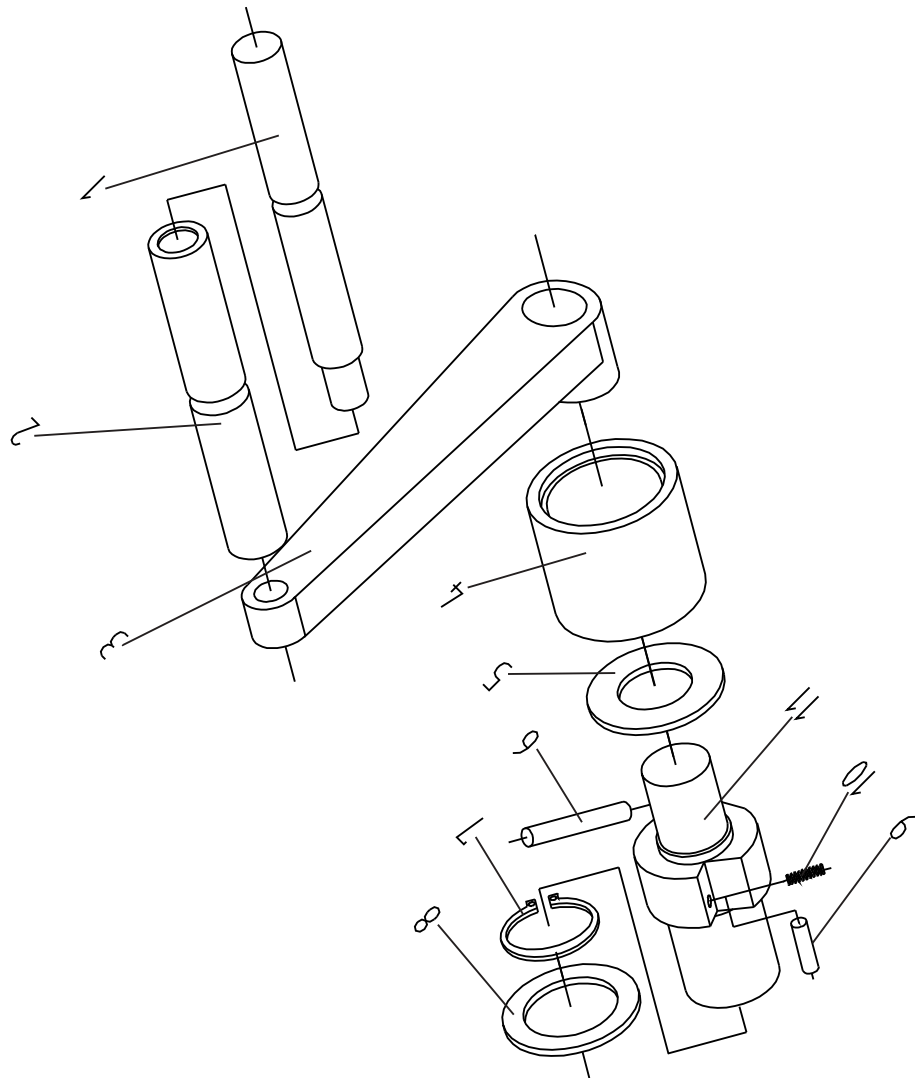

15. Starter handle assembly

No.	Parts number
1	Handle sleeve
2	Handle
3	Starter crank
4	Starter claw
5	Rear retaining ring
6	Starter claw pin
7	Retaining ring 30
8	Front retaining ring
9	Column pin
10	Spring
11	Brake ratchet