

# GBE2245

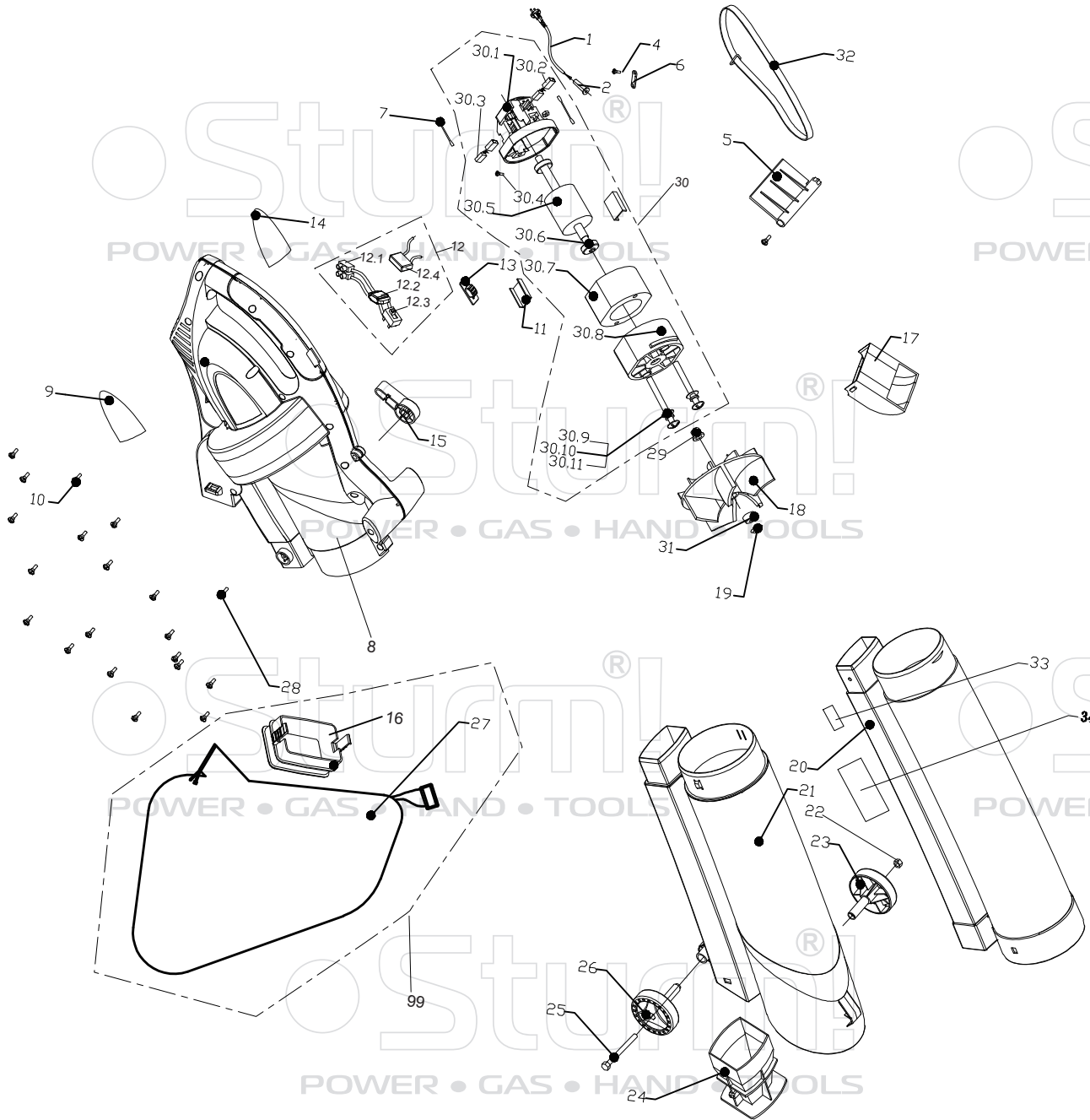

NO.	DESCRIPTION	NO.	DESCRIPTION
1	CABLE	23	LEFT WHEEL
2	CABLE JACKET	24	NOZZLE
4	SCREW	25	BOLT M5X80
5	WIND BLOCK	26	RIGHT WHEEL
6	CABLE CLAMP	27	COLLECTING BAG
7	STRAP	28	ONE-WAY SCREW
8	HOUSING ASSEMBLY	29	AXLE SLEEVE
9	RIGHT LABEL	30	MOTOR ASSEMBLY
10	SCREW	30.1	REAR BRACKET MOTOR
11	RUBBER PAD	30.2	CARBON BRUSH HOLDER
12	INNER COMPONENT ASSEMBLY	30.3	CARBON BRUSH
12.2.1	TERMINAL BLOCK	30.4	HEX NUT M8
12.2.2	INDUCTANCE	30.5	ROTOR
12.2.3	SWITCH	30.6	BEARING 608Z
12.2.4	CAPACITOR	30.7	STATOR
13	SWITCH BUTTON	30.8	FRONT BRACKET
14	LEFT LABEL	30.9	BOLT M5X75
15	FUNCTION SELECTOR	31.0	FLAT WASHER
16	COLLECTING BAG COUPLER	30.11	SPLIT WASHER
17	SAFETY BLOCK	31	HEX NUT M5
18	FAN	32	SHOULDER STRAP
19	CAP	33	WARNING LABEL 1
20	UPPER HOUSING	34	WARNING LABEL 2
21	BOTTOM HOUSING	99	COLLECTION BAG
22	HEX NUT		

ST20140516