

# GC99456, GC99458

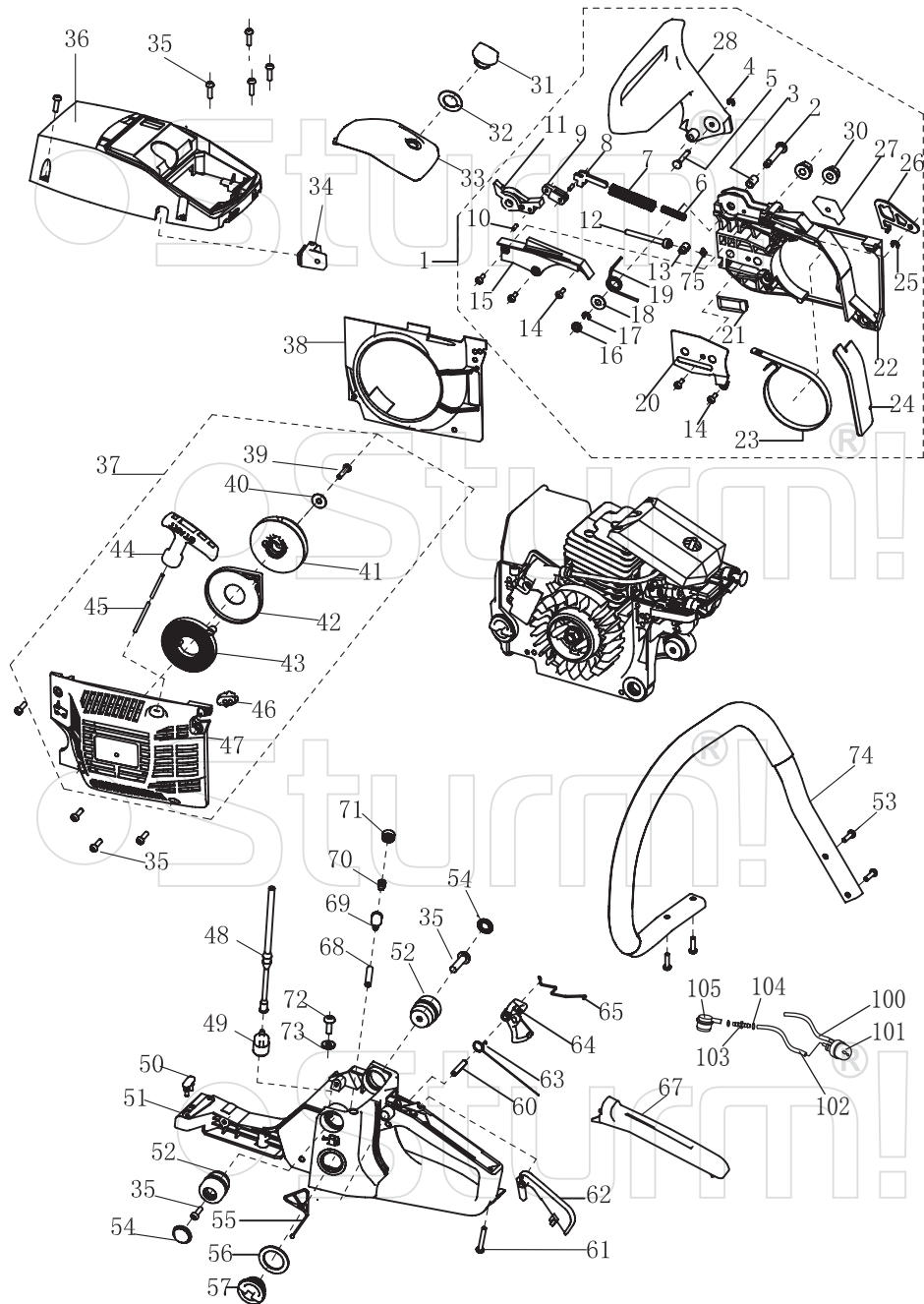

NO.	DESCRIPTION	NO.	DESCRIPTION
1	RIGHT COVER ASSEMBLY	41	START PLATE
2	SHIELD PIN	42	COIL-SPRING GLAND
3	SHIELD PIN GLAND	43	START COIL-SPRING
4	RING 3	44	START HANDLE
5	SPACER PIN	45	START STRETCHING WIRE
6	SECONDARY BRAKE SPRING	46	LH SHEATHING
7	BRAKE SPRING	47	START COVER
8	BRAKE CONTROL ROD	48	FUEL TUBE
9	SECONDARY PULL-ROD	49	PETROL FILTER COMPONENTS
10	PIN 3X9	50	SHOCK RUBBER
11	MAIN LEVEL	51	BASE
12	TIGHTENER SCREW	52	SHOCK RUBBER GLAND
13	TENSION BLOCK	53	TAPPING SCREW ST5X16
14	TAPPING SCREW ST4X8	54	DUST COVER
15	BRAKE SPRING COVER PLATE	55	ANTI-DROP PLATE
16	SHOCK RUBBER WASHER	56	PACKING WASHING 20X30X2
17	SHIELD RING 5	57	OIL COVER
18	WASHER 6	60	PIN6X30
19	BRAKE TORSION ROD SPRING	61	TAPPING SCREW ST4X25
20	TENSIONER COVER PLATE	62	TRIGGER CONTROL RACK
21	CHAIN GUIDE DOG	63	TRIGGER TORSION ROD SPRING
22	RIGHT COVER	64	TRIGGER
23	BRAKE STRAP	65	THROTTLE
24	DUST SHIELD	67	HANDLE COVER
25	SHIELD RING 4	68	BALANCER OIL TUBE
26	SPACING SHIELD	69	BALANCER BODY
27	SHOCK RUBBER CUSHING	70	BALANCER RUBBER
28	FRONT DAMPER	71	BALANCER COVER
30	NUT M8	72	SEALING RUBBER
31	AIR FILTER LOCK NUT	73	TAPPING SCREW ST4X13
32	LOCK NUT WASHER 15X26X1	74	FRONT HANDLE ASSEMBLY
33	AIR FILTER COVER	75	POSITION BLOCK
34	IDLE ADJUSTING GUIDE SET	100	PUMP TUBE
35	SCREW M5X16	101	PRIMER BULB
36	UPPER COVER PLATE	102	SCAVENGE TUBE
37	STARTER ASSEMBLY	103	OIL TUBE TIE-IN
38	BOSSING	104	OIL TUBE CLIP
39	SCREW M5X10	105	SCAVENGE NOZZLE
40	WASHER 5		

ST20101012-01

Sturmm!

# ENGINE FOR GC99456, GC99458

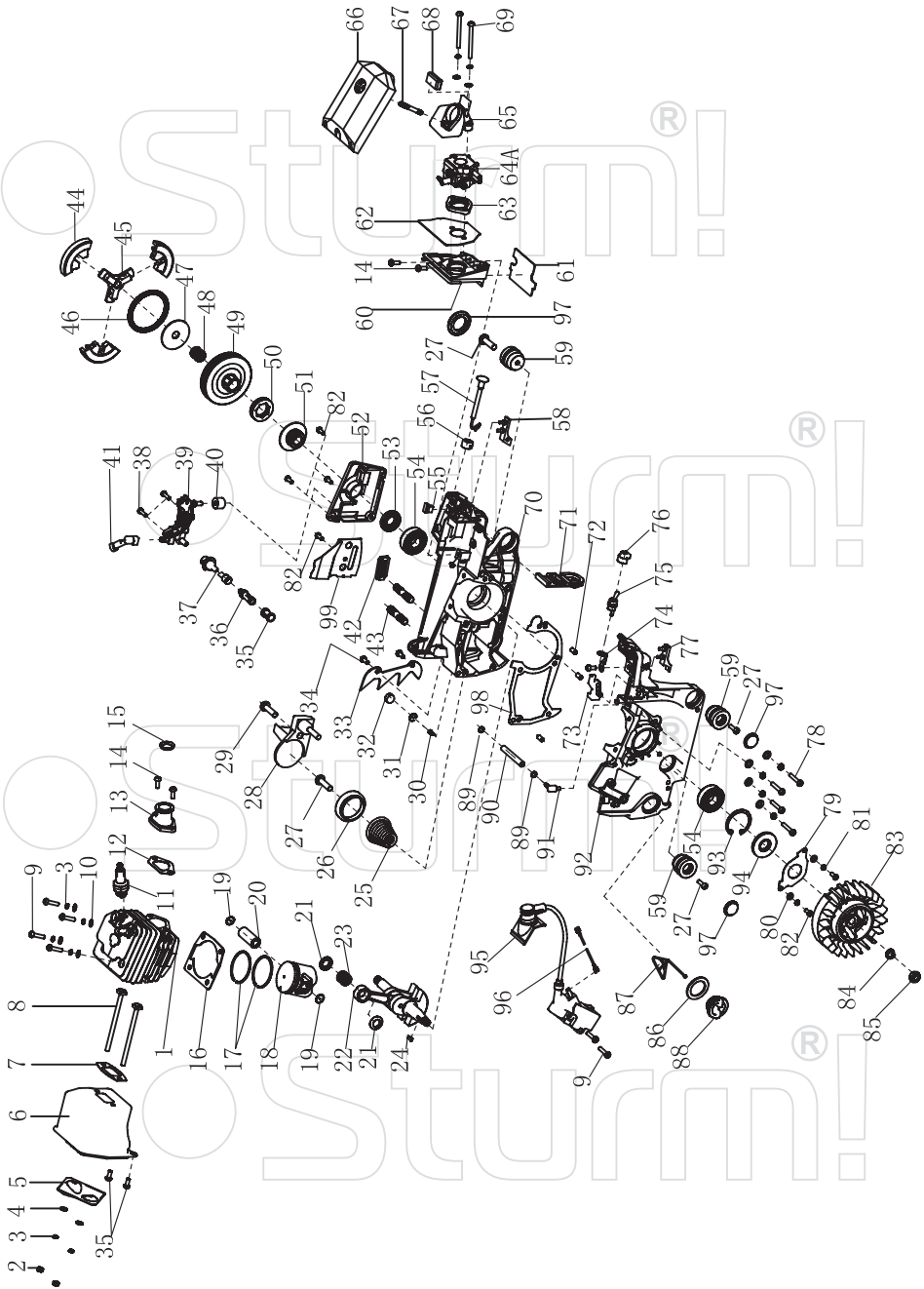

NO.	DESCRIPTION	NO.	DESCRIPTION
1	CYLINDER BODY	51	TURBINE
2	NUT M5	52	COVER PLATE
3	WASHER 5	53	OIL SEAL 15X28X4.5
4	WASHER 5	54	BEARING 6202 GRADE D 15X35X11
5	SILENCER COVER PLATE	55	SHOCK BLOCK 1
6	SILENCER BODY	56	THROTTLE LEVER RETAINING BRACKET
7	SILENCER SEALING PLATE	57	THROTTLE ROD
8	MUFFLER CONNECTING SCREW	58	RIGHT SHOCK BLOCK
9	SCREW M5X20	59	CUSHION SOCKET
10	WAHSER 5	60	AIR INTAKE SUPPORT
11	SPARK PLUG NHSP LD L8RTF	61	BACKING BOART
12	AIR INTAKE TUBE SEALING PLATE	62	SEALING PLATE OF AIR INTAKE SUPPORT
13	AIR INTAKE TUBE	63	AIR INTAKE FLANGE
14	SCREW M5X12	64A	CARBURETOR
15	HOLD COIL	65	AIR INTAKE SOCKET
16	CYLINDER SEALING PLATE	66	AIR FILTER
17	PISTON RING	67	DOUBLE-SCREW BOLT GM5-M5X30
18	PISTON	68	CUSHION OF AIR INTAKE SOCKET
19	PISTON PIN CIRCLIP	69	NUT M5X50
20	PISTON PIN	70	RIGHT CASE BODY
21	NEEDLE BEARING RING	71	DUST PLATE
22	CRANKSHAFT CONNECTING BAR COMPONENTS	72	PIN 5X10
23	NEEDLE BEARING 11X15X12.5	73	SHOE BLOCK 2
24	SEMICIRCULAR KEY 3X3.5X10	74	GROUND SRIP
25	CONICAL SPREADER SPRING	75	EXTINCTION SWITCH
26	CONICAL SPREADER BASE	76	EXTINCTION SWITCH SOCKET
27	TAPPING SCREW ST5X16	77	LEFT SHOCK BLOCK
28	CHAIN CATCHER	78	SCREW M5X25
29	SCREW M5X16	79	OIL SEAL DAMPER
30	AERATION JET	80	WASHER 4
31	AERATION JET CIRCLIP	81	WASHER 4
32	SPONGE TRANSITION BLOCK	82	SCREW M4X10
33	BUMPER SPIKES	83	FLYWHEEL
34	SCREW M5X10	84	WASHER 8
35	OIL FILTER SCREEN	85	NUT M8X1
36	OIL FILTER	86	PACKING WASHING 20X30X2
37	OIL TUBE	87	ANTI-DROP PLATE
38	SCREW M4X14	88	OIL COVER
39	OIL PUMP	89	SUCTION TUBE CIRCLIP
40	SPONGE TRANSITION COIL	90	SUCTION TUBE 2.5X7X105
41	NOZZLE	91	SUCTION JET
42	CHAIN GUIDE BLOCK	92	LEFT CASE BODY
43	DOUBLE-SCREW BOLT AYM8-M8X26-8.8	93	RING35
44	SHOE BLOCK	94	OIL SEAL 15X35X4.5
45	RETAINER	95	IGNITER
46	CLUTCH EXTENSION SPRING	96	EXTINCTION CONDUCTOR
47	CLUTCH ADJUSTING WASHER	97	DUST COVER
48	NEEDLE BEARING 12X15X14.5	98	CASE BODY SEALING PLATE
49	CLUTCH SHELL	99	DAMPER
50	SPROCKET		