

ENGINE FOR GS8213G

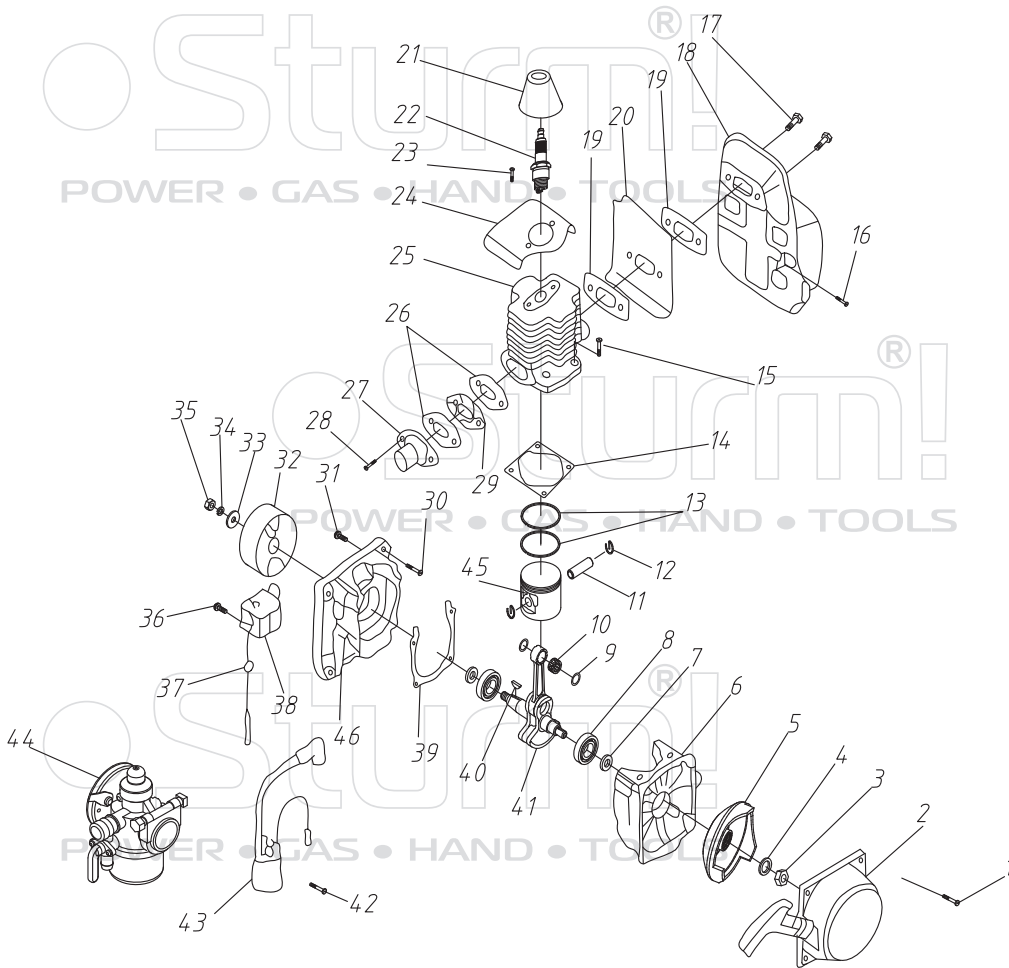

NO.	Description
1	Screw Asm
2	Starter
3	Nut
4	Washer
5	Ratchet
6	Back Crankcase
7	Seeling
8	Bear
9	Washe
10	Bearing
11	Pistonpin
12	Ring
13	Pinson Ring
14	Cylinder Gasket
15	Screw
16	Screw Asm
17	Screw
18	Muffle
19	Gasket
20	Muffle Plate
21	Spark Cover
22	Spark
23	Screw Asm
24	Cover
25	Cylinder
26	Seeling Gasket
27	Inlet Tube
28	Screw Asm
29	Heat Pad
30	Screw
31	Screw
32	Flywheel
33	Washer
34	Washer
35	Nut
36	Screw
37	Fixity
38	Winding
39	Seeling Gasket
40	Key
41	Crankshaft
42	Screw
43	Ignitor
44	Carburettoe
45	Piston
46	Front Crankcase

UK-ST20191218

GS8213G

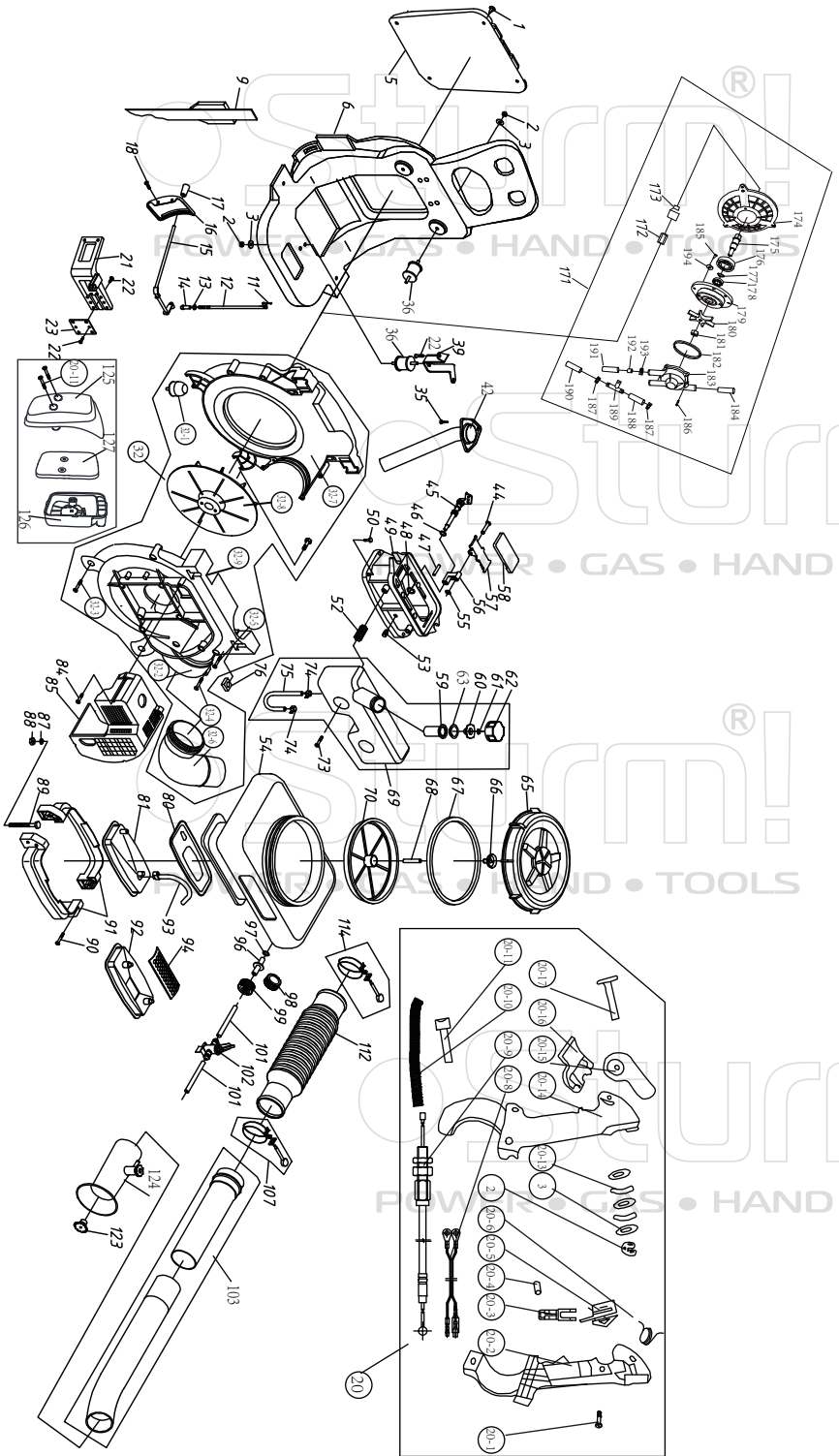

NO.	Description	NO.	Description
1	Clip	62	Fuel Tank Cap
2	Nut	63	Washer
3	Washer	65	Spray Tank Cap
5	Frame	66	Air Valve
6	Pad	67	Gasket
9	Belt	68	Water Pipe
11	Split Pin	69	Fuel Tank
12	Pulling Rot	70	Strainer
13	Nut	73	Blot Assy
14	Connector	74	Clip
15	Dust Rot	75	Water Rube
16	Graduoor	76	Nut
17	Handle	80	Washer
18	Blot Assy	81	Misting Plate
20	Control Box	84	Screw
20-1	Screw	85	Engine Cover
20-2	Right Box	87	Washer
20-3	Spring	88	Nut
20-4	Spacer	89	Bolt
20-5	Switch	90	Blot Assy
20-6	Spring	91	Clamp
20-8	Stop-line	92	Dusting Plate
20-9	Cable Accelerator	93	Tube
20-10	Pipe	94	Plate
20-11	Bolt Assy	96	Link Pipe
20-13	Spring Washer	97	Gasket
20-14	Let Box	98	Lid
20-15	Lock Shaft	99	Spray Tank Cap
20-16	Handgrip	101	Pipe
20-17	Shaft	102	Switch
21	Suppor Compment	103	Pipe Assy
22	Bolt Assy	107	Clasp combination
23	Plate	112	Large hose
32	Worm	114	Clasp combination
32-1	Suppor Compment	123	Rotary sprinkler head
32-2	Fan Warning Label	124	Black nozzle assembly
32-3	Screw	125	Air filter cover
32-4	Screw	126	Inner cover of air filter
32-5	Screw	127	Filter element
32-6	Clamp	171	Booster Pump
32-7	Worm Case	172	Interzonal Fibers
32-8	Fan	173	Adapter Sleeve
32-9	Worm Case	174	Booster Pump Net
35	Screw	175	Pump Spindle
36	Rubber	176	Bearing
39	Support	177	Washer On Shaft
42	Pipe	178	Oil Seal
44	Slide Pin	179	Booster Pump Volute
45	Rocket Shaft	180	Impeller
46	Oring	181	Nut
47	Shaft	182	Booster Pump Seal
48	Ring	183	After The Pump Shell
49	Shutter	184	Water Tube
50	Blot Assy	185	Screw
52	Fuel Tank Support	186	Screw
53	Plug	187	Clamp
54	Spray Tank	188	Water Tube
55	Ring	189	Tee
56	Support Arm	190	Water Tube
57	Rubber Plate	191	Water Tube
58	Slide	192	Closure Sleeve
59	Fuel Strainer	193	Clamp
60	Tid	194	Washer
61	Filter		