

# PC8805DK

NO.	DESCRIPTION	NO.	DESCRIPTION
1	the foam of handle grip	41	hex bolt M8x16
2	handle	42	shock-reducing rubber block
3	cord switch	43	rubber block
4	snap-head bolt	44	hex bolt M8x50
5	hex-nut M6	45	engine amounting plate
6	spring pin	46	flat washer 10N
7	cap nut	47	hex nut M10
8	tension spring	48	hex bolt M6x16
9	pipe end cap	49	spring washer 6
11	hex bolt M6x40	50	right bearing cover
12	flat washer 6N	51	seal ring
13	hook	52	bearing 6307
14	connection frame for handle	53	circlip for hole 80
15	hex bolt M10x65	54	vibration shaft
16	shock-reducing rubber ring	58	left bearing cover
17	self-locking nut	59	Lip oil seal 30x42x7
18	rubber gasket	60	flat washer 6 x 6 x 20
19	seal ring 5	61	pulley
20	petrol engine	62	pulley circlip
21	hex flange nut M8	63	bottom plate
22	fixed plate for bolt	64	shock-reducing rubber block
23	adjusting washer	65	hex flange nut M10
24	Oil drain pipe	66	end nut
25	clutch spring	67	washer
26	clutch friction block	68	split pin 2.5 x 25
27	clutch core	69	flat washer 14N
28	clutch belt pulley	70	5" wheel
29	bearing 6006-LS	71	hex self-locking nut M12
30	circlip for shaft 30	72	hex bolt M10x30
31	circlip for hole 55	73	connection rod
32	flat washer 8N	74	transport frame
33	spring washer 8	75	hex bolt M12x25
34	hex bolt M8x25	76	rubber pad
35	fixed plate belt cover	77	rubber pad splint
36	V-belt	79	hex bolt M10 x 35
37	belt cover		
38	flat washer 8N		
39	hex nut M10		
40	hex nut M8		

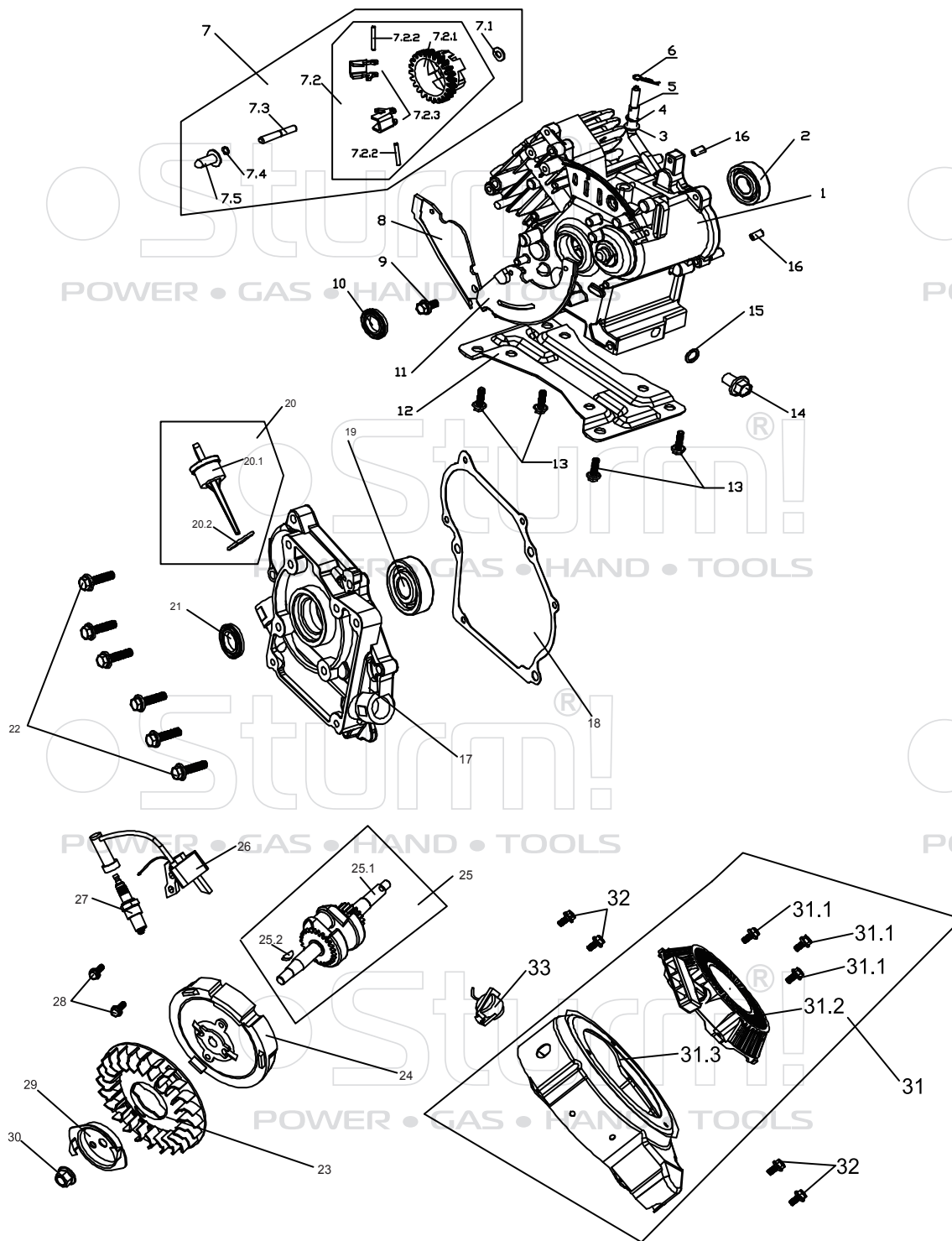

## THE ENGINE FOR PC8805DK-1

NO.	DESCRIPTION	NO.	DESCRIPTION
1	Crankcase body	20	Oil gauge ass
2	Ball bearing 6303	20.1	Oil gauge
3	Washer, Slip cap	20.2	Seal , Oil gauge
4	Split clip 6	21	Oil seal 17×30×6
5	Sway bar	22	Bolt
6	Split clip	23	Flywheel fan
7	Centrifugal gear parts	24	Flywheel
7.1	Washer, Slip cap	25	Crankshaft ass
7.2	Centrifugal gear A ss	25.1	Crankshaft
7.2.1	Centrifugal gear	25.2	Woodruff key
7.2.2	Pin,centrifugal blokc	26	Ignition coil ass
7.2.3	Centrifugal block	27	Spark plug
7.3	Center axis	28	Bolt
7.4	Clip, Center Axis	29	Starter sleeve
7.5	Slip cap	30	Nut M12 ×1.25
8	Left wind guide	31	Recoil starter ass
9	Bolt M6x12	31.1	Bolt
10	Oil seal 17X30X6	31.2	Starter
11	Right wind guide	31.3	Fan cover
12	Motherboard	32	Bolt
13	Bolt M8X20	33	Engine Switch
14	Drain bolt M10X1.25X15		
15	Washer, drain bolt		
16	Set pin Φ8×14		
17	Crankcase cover		
18	Gasket , Crankcase		
19	Ball bearing 6303		

UK-ST20191128

# THE ENGINE FOR PC8805DK-2

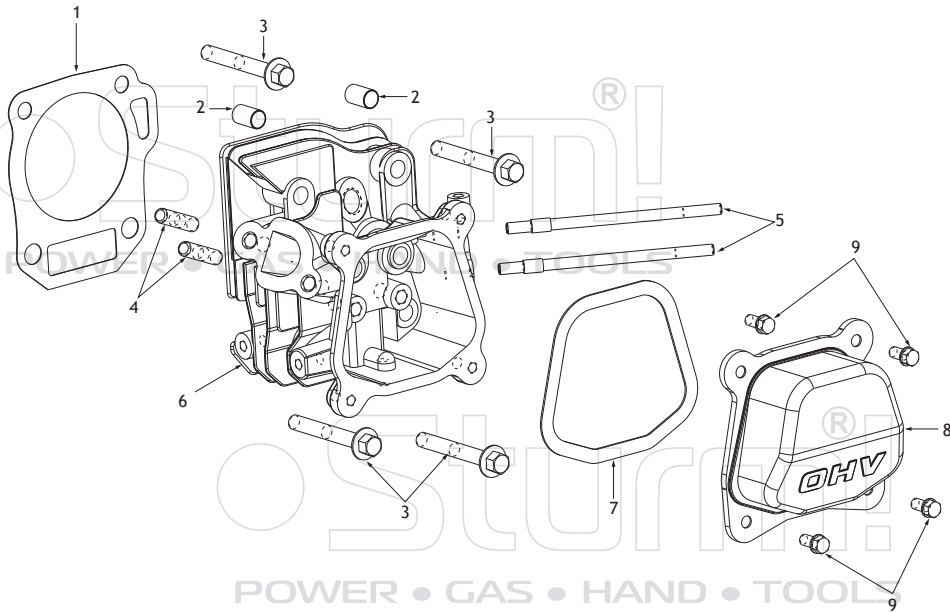

NO.	DESCRIPTION
1	Gasket, Cylinder head
2	Set pin
3	Bolt
4	Stud, Exhaust port
5	Stud, Intake port
6	Cylinder head ass.
7	Gasket, cylinder head cover
8	Cylinder head cover
9	Bolt
10	Camshaft ass.
11	Tappet
12	Pusher
13	Pusher guide
14	Intake valve
15	Oil seal, Intake valve
16	Valve spring
17	Spring seat, Intake valve
18	Rocker ass.
18.1	Stud, Rocker ass.
18.2	Rocker
18.3	Adjust nut, sphere
18.4	Lock nut
19	Spring seat, Exhaust valve
20	Exhaust valve

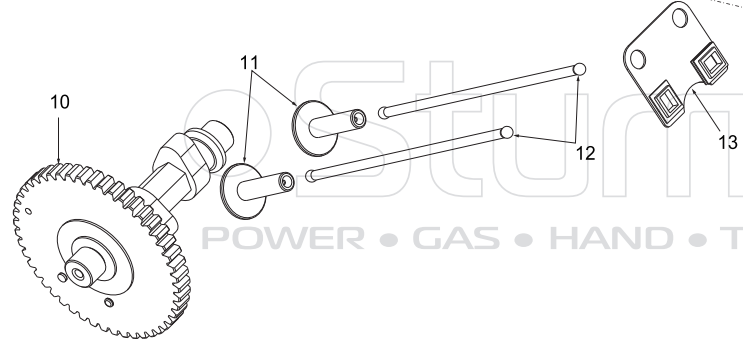
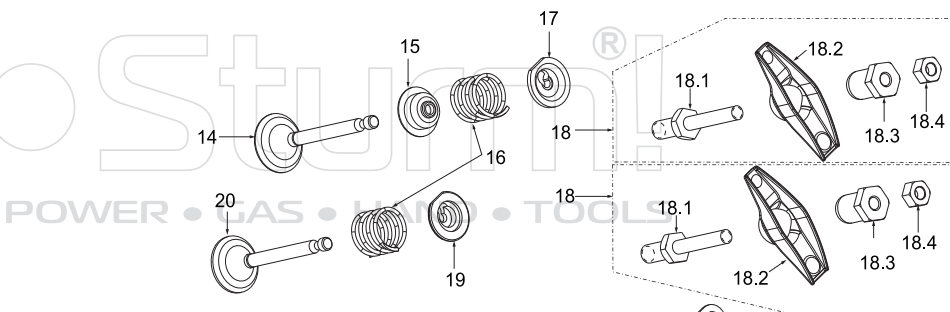

UK-ST20191128

# THE ENGINE FOR PC8805DK-3

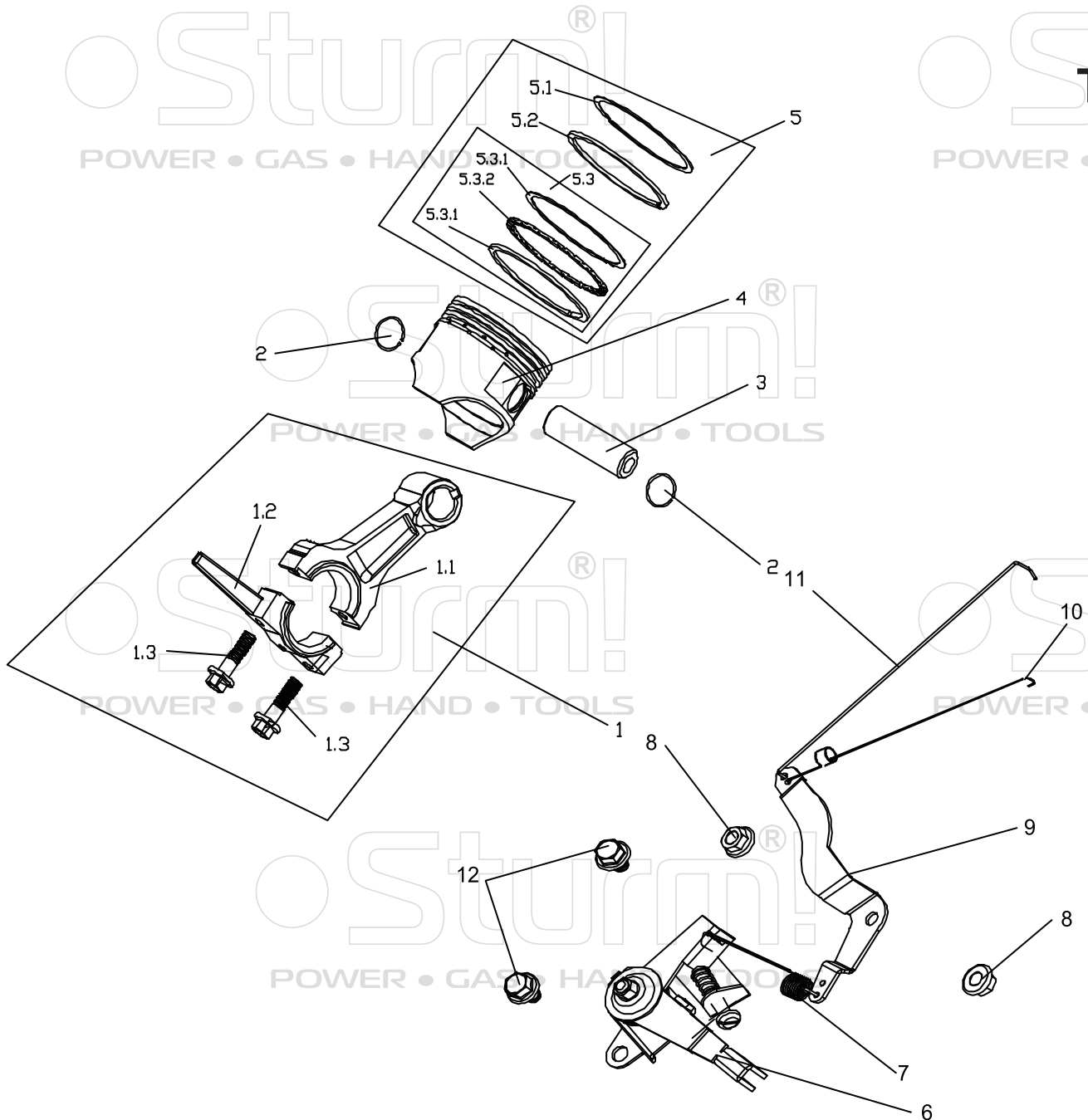

NO.	DESCRIPTION
1	Connecting rod ass
1.1	Body , Connecting rod
1.2	Cover,Connecting rod
1.3	Bolt,connecting rod
2	Clip,piston pin
3	Piston pin
4	Piston
5	Piston ring ass
5.1	First air ring
5.2	Second air ring
5.3	Oil ring ass
5.3.1	Scraper ring
5.3.2	Set off ring
6	Speed adjustment base parts
7	Return spring
8	Nut
9	Speed adjustment arm
10	Fine adjustment spring
11	Pulling rod
12	Bolt

UK-ST20191128

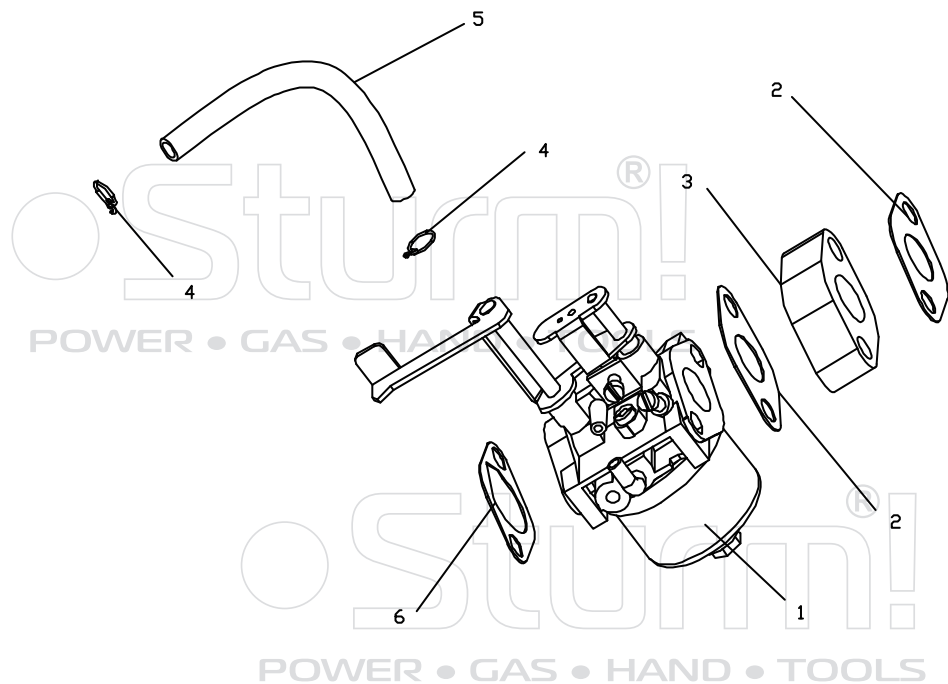

## THE ENGINE FOR PC8805DK-4

NO.	DESCRIPTION
1	Carburetor ass
2	Gasket , carburetor
3	Block , carburetor
4	Clip , fuel tube
5	Fuel tube
6	Gasket , Air cleaner
7	Air cleaner ass
7.1	Bolt
7.2	Air cleaner cover
7.3	Foam
7.4	Support foam
7.5	Air cleaner body
8	Air duck
9	Nut

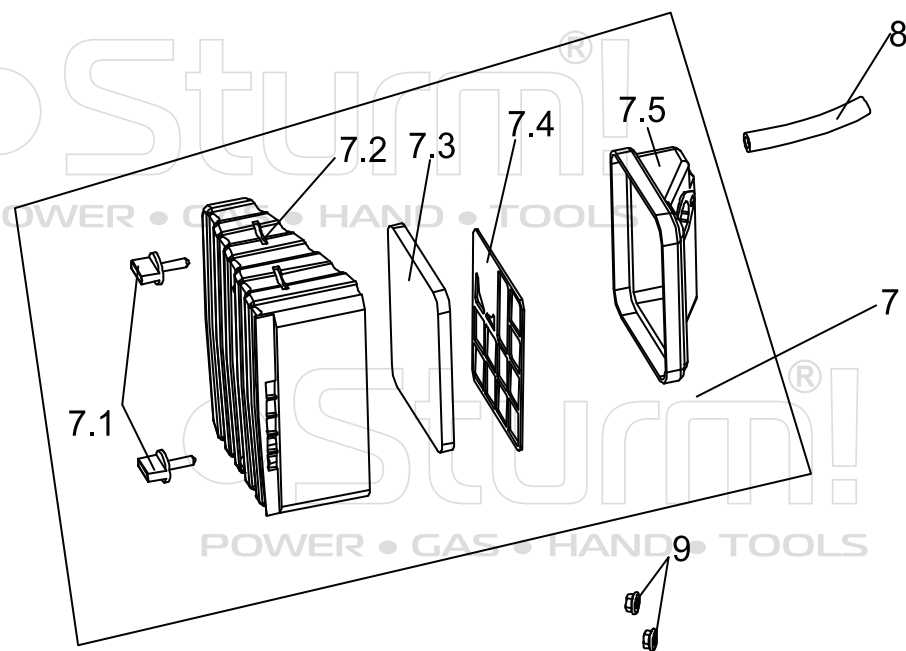

UK-ST20191128

# THE ENGINE FOR PC8805DK-5

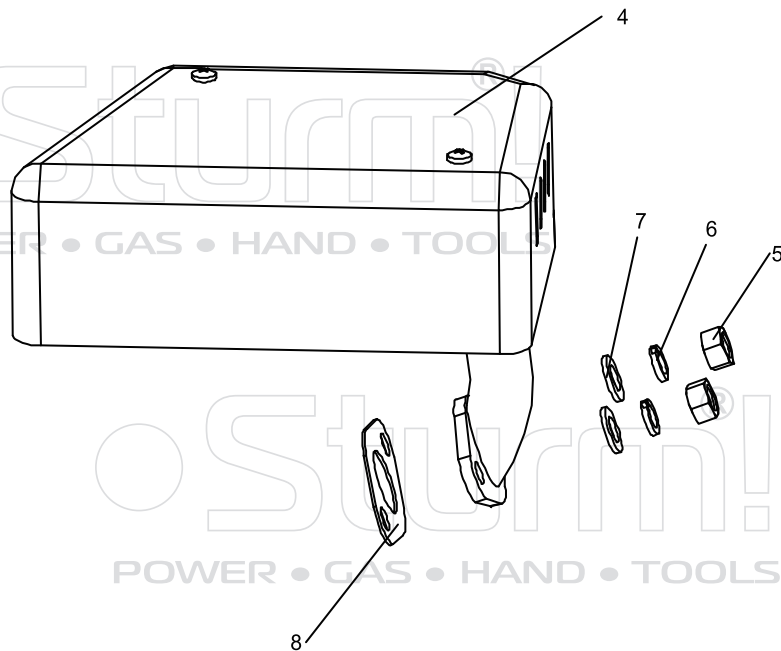
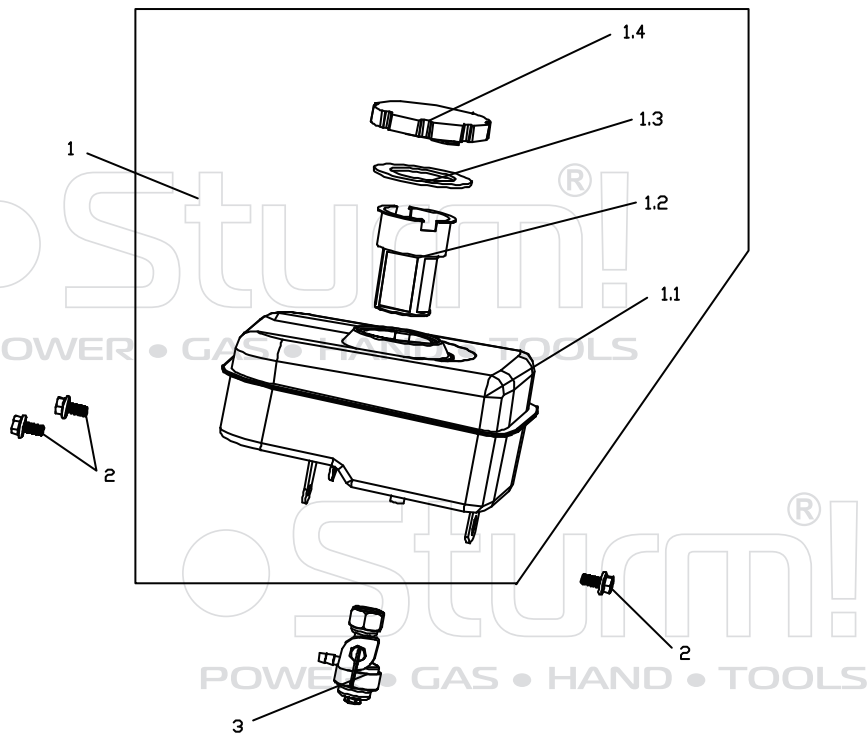

NO.	DESCRIPTION
1	Fuel tank ass
1.1	Fuel tank
1.2	Filter
1.3	Seal , Fu el tank cover
1.4	Fuel tank cover
2	Bolt
3	Fuel on - Off ass
4	Muffler ass
5	Nut
6	Spring washer
7	Washer
8	Gasket muffler

UK-ST20191128