

# PC8809DKW

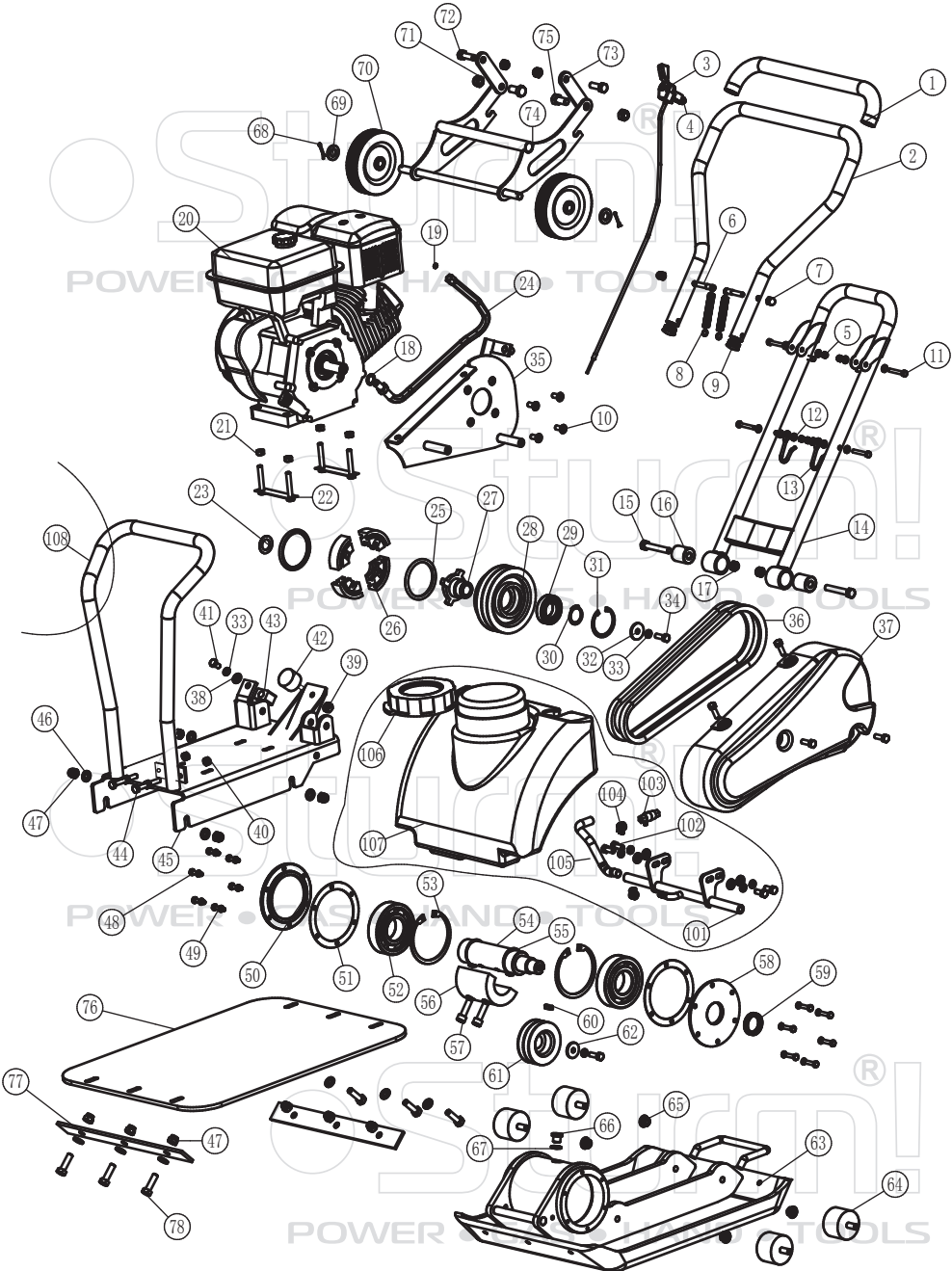

NO.	DESCRIPTION	NO.	DESCRIPTION
1	the foam of handle grip	45	engine amounting plate
2	handle	46	flat washer 10N
3	cord switch	47	hex nut M10
4	+ snap-head bolt	48	hex bolt M6x16
5	hex-nut M6	49	spring washer 6
6	spring pin	50	right bearing cover
7	cap nut M8	51	seal ring
8	tension spring	52	bearing 6309
9	pipe end cap	53	circlip for hole 100
10	hex sunk screw M8x20	54	vibration shaft
11	hex bolt M6x40	55	Hex bolts M10X30
12	flat washer 6N	56	Eccentric iron
13	hook	57	circlip for shaft 45
14	connection frame for handle	58	left bearing cover
15	hex bolt M10x65	59	Lip oil seal 30x42x7
16	shock-reducing rubber ring	60	Flat Key
17	self-locking nut M10	61	pulley
18	rubber gasket	62	pulley circlip
19	seal ring 5	63	bottom plate
20	petrol engine	64	shock-reducing rubber block
21	hex flange nut M8	65	hex flange nut M10
22	fixed plate for bolt	66	end nut
23	ajusting washer	67	washer
24	Oil drain pipe	68	split pin 2.5 x 25
25	clutch spring	69	flat washer 14N
26	clutch friction block	70	5" wheel
27	clutch core	71	hex self-locking nut M12
28	clutch belt pulley	72	hex bolt M10x30
29	bearing 6006-LS	73	connection rod
30	circlip for shaft 30	74	transport frame
31	circlip for hole 55	75	hex bolt M12x25
32	flat washer 8N	76	rubber pad
33	spring washer 8	77	rubber pad splint
34	hex bolt M8x25	78	hex bolt M10 x 35
35	fixed plate belt cover	101	outlet pipework
36	V-belt	102	hex bolt M8x20
37	belt cover	103	Valve
38	flat washer 8N	104	Pipe Clamp
39	hex nut M10	105	water pipe
40	hex nut M8	106	water tank cover
41	hex bolt M8x16	107	water tank
42	shock-reducing rubber block	108	Water tank frame
43	rubber block		
44	hex bolt M8x60		

# THE ENGINE FOR PC8809DKW-1

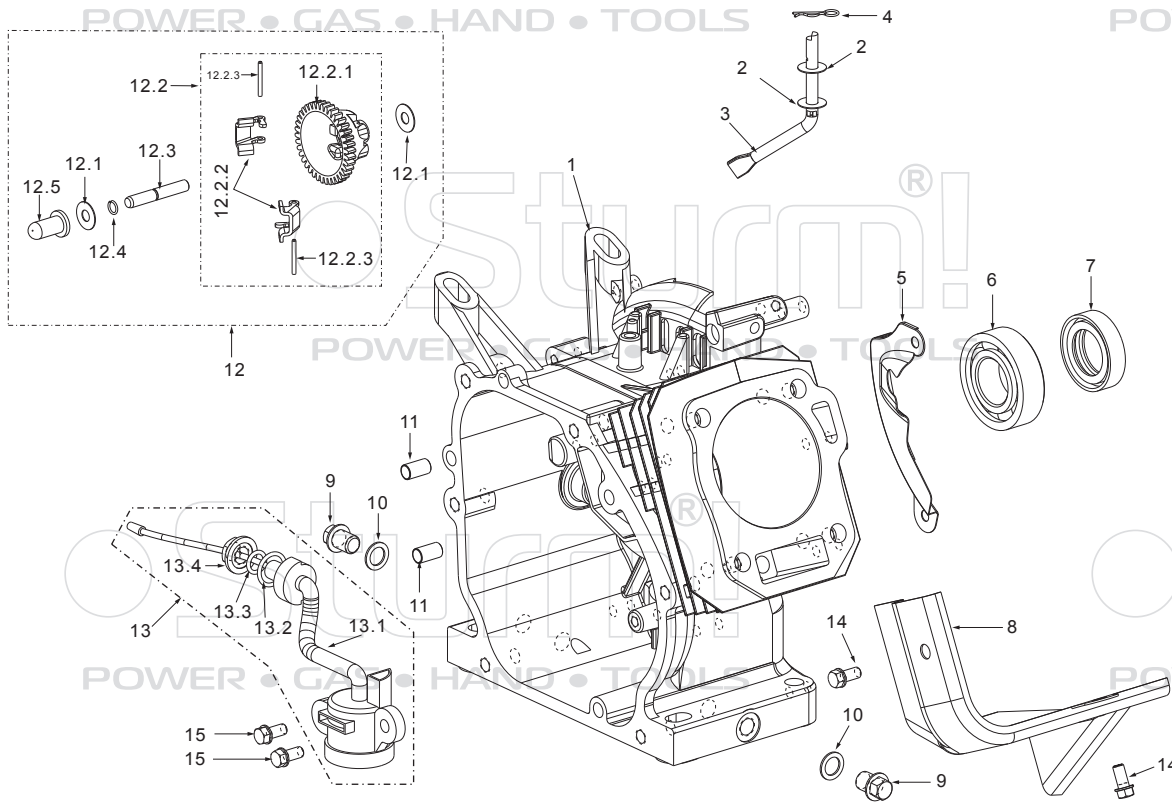

NO.	DESCRIPTION
1	Crankcase body
2	Washer, Slip cap
3	Sway bar
4	Split clip
5	Side plate
6	Ball bearing 6205
7	Oil sealΦ25×41.25×6
8	Wind guide
9	Drain bolt M10 ×1.25×15
10	Washer, Drain bolt
11	Set pinΦ8×14
12	Centrifugal gear parts
12.1	Washer, Slip cap
12.2	Centrifugal gear ass.
12.2.1	Centrifugal gear
12.2.2	Centrifugal block
12.2.3	Pin, Centrifugal block
12.3	Center axis
12.4	Clip, Center axis
12.5	Slip cap
13	Oil sensor ass.
13.1	Oil sensor body
13.2	O-ringΦ17×Φ2
13.3	O - ring
13.4	Nut M10
14	Bolt M6 ×10
15	Bolt

UK-ST20191128

## THE ENGINE FOR PC8809DKW-2

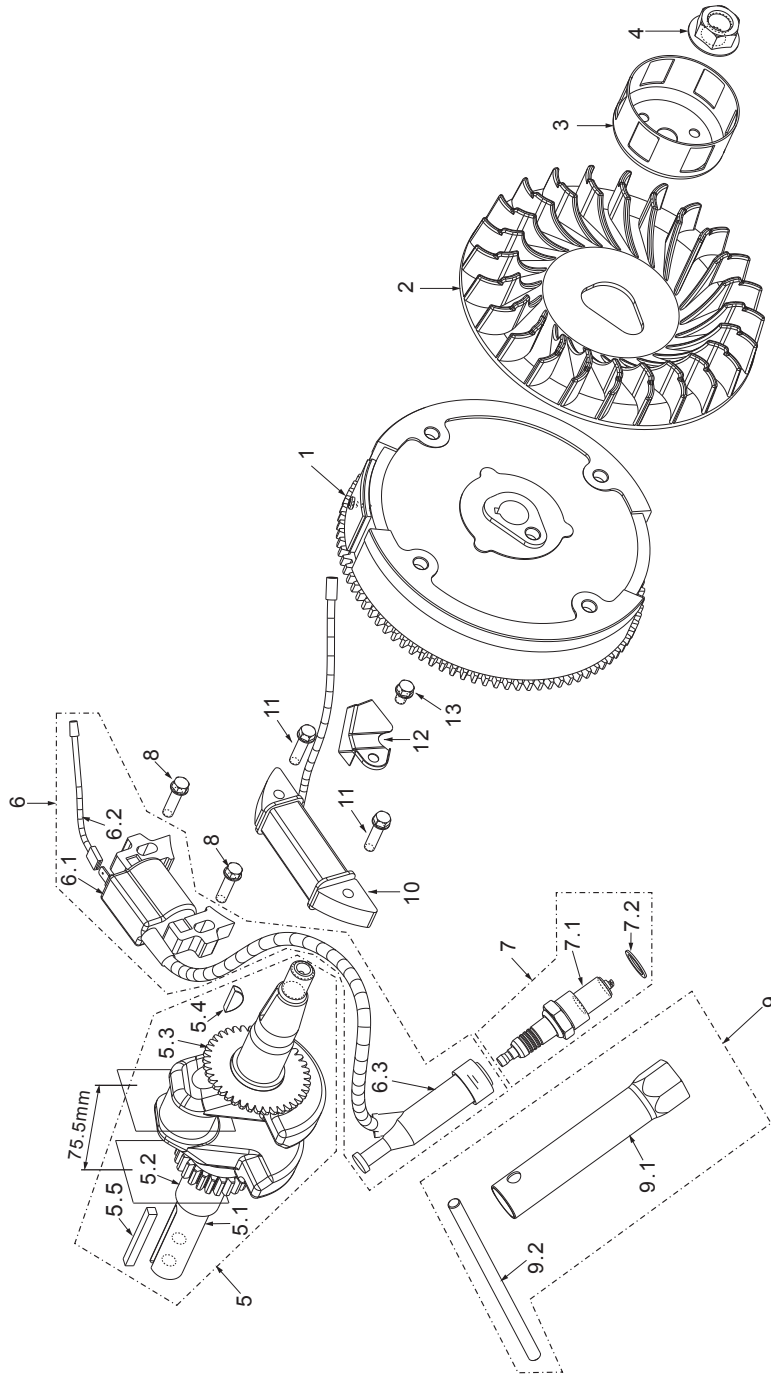

NO.	DESCRIPTION
1	Flywheel ass.
2	Flywheel fan
3	Starter sleeve
4	Nut, Flywheel ass.
5	Crankshaft ass.
5.1	Crankshaft
5.2	Timing gear
5.3	Governor gear
5.4	Woodruff key
5.5	Flat key
6	Ignition coil ass.
6.1	Ignition coil
6.2	Stop lead
6.3	Spark plug cap
7	Spark plug ass.
7.1	Spark plug
7.2	Washer, Spark plug
8	Bolt
9	Tools
9.1	Wrench, Spark plug
9.2	handle
10	Charge coil
11	Bolt
12	Fixer, Charge coil
13	Bolt

# THE ENGINE FOR PC8809DKW-3

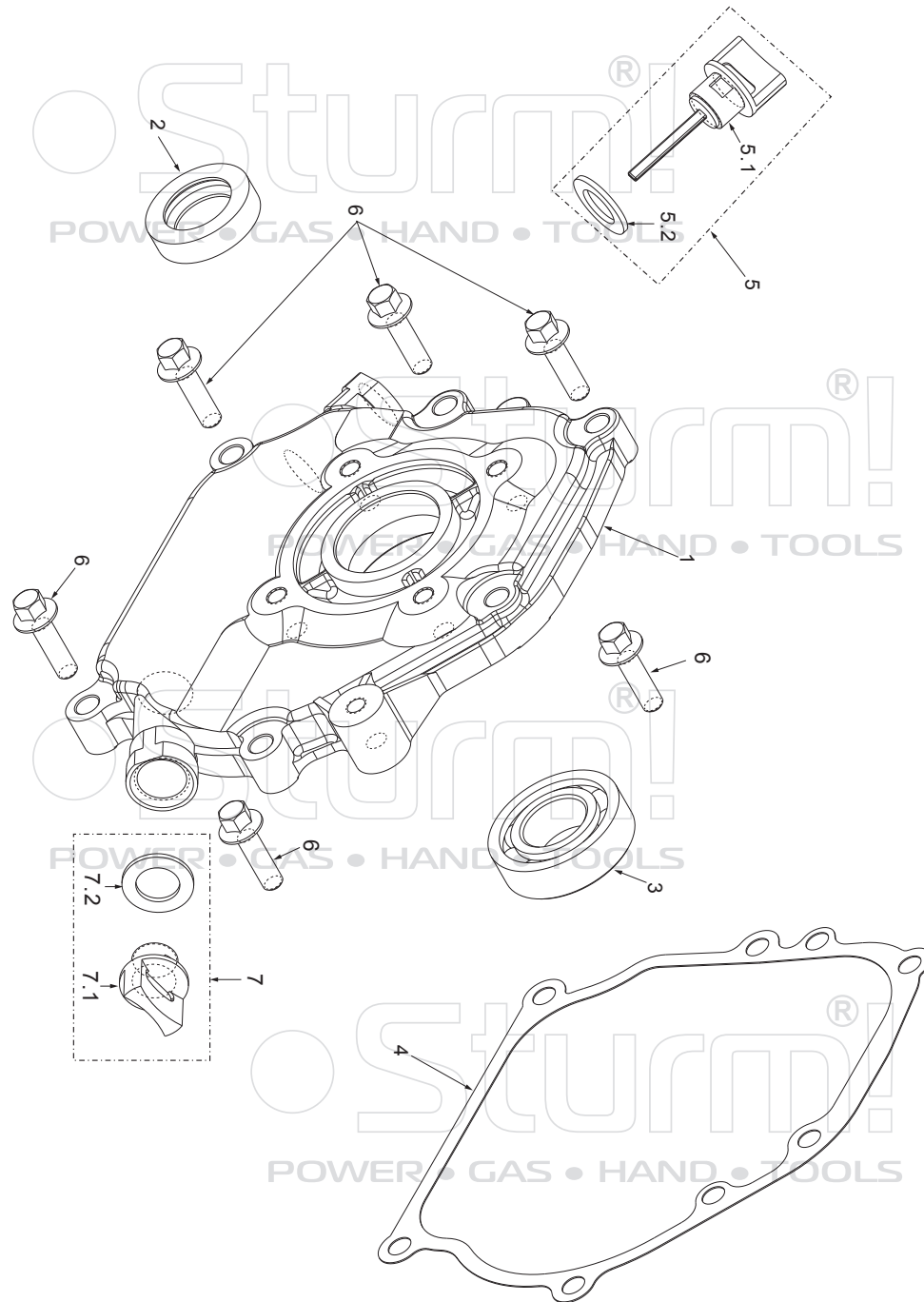

NO.	DESCRIPTION
1	Crankcase cover
2	Oil seal
3	Ball bearing
4	Gasket, Crankcase
5	Oil gauge ass.
5.1	Oil gauge 1
5.2	Seal, Oil gauge
6	Bolt
7	Oil plug ass.
7.1	Oil plug 1
7.2	Seal, Oil plug

UK-ST20191128

# THE ENGINE FOR PC8809DKW-4

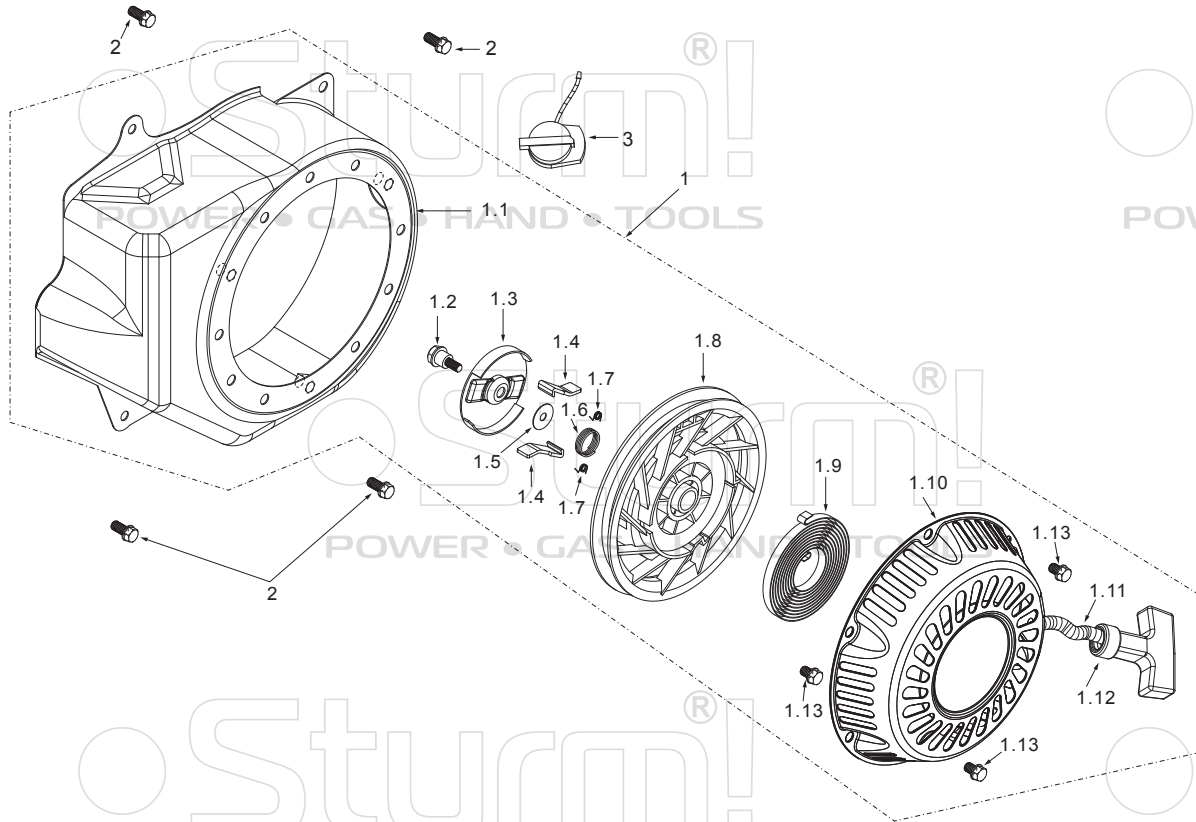

NO.	DESCRIPTION
1	Recoil starter ass.
1.1	Fan cover
1.2	Pivot bolt
1.3	Ratchet guide
1.4	Ratchet
1.5	Washer
1.6	Friction spring
1.7	Ratchet spring
1.8	Roller
1.9	Starter spring
1.10	Starter cover
1.11	Rope
1.12	Pulling handle
1.13	Bolt
2	Bolt
3	Current amplifier

UK-ST20191128

POWER • GAS • HAND • TOOLS

POWER • GAS • HAND • TOOLS

Sturm!  
POWER • GAS • HAND • TOOLS

Sturm!  
POWER • GAS • HAND • TOOLS

## THE ENGINE FOR PC8809DKW-5

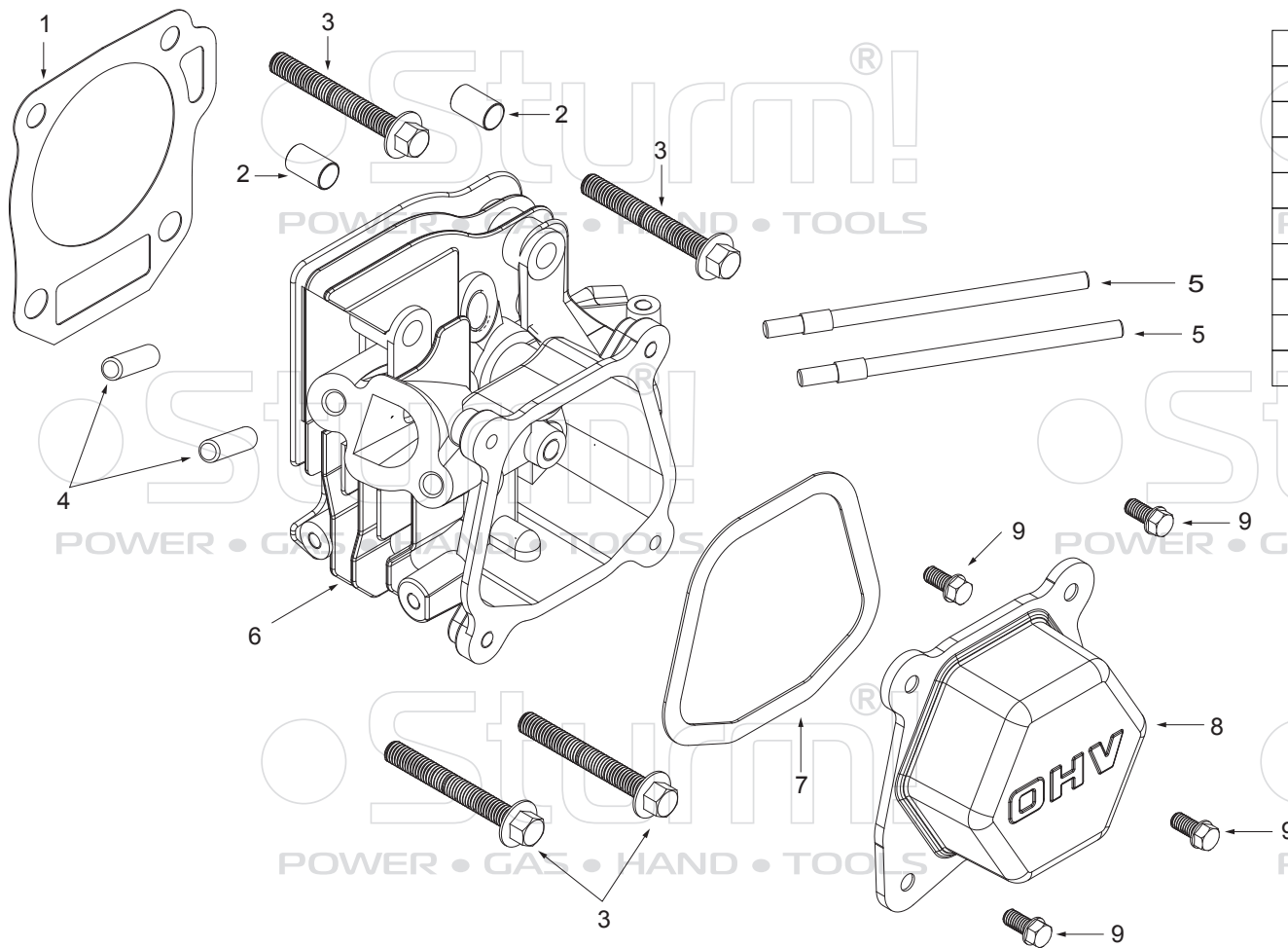

NO.	DESCRIPTION
1	Gasket, Cylinder head
2	Set pin
3	Bolt
4	Stud, Exhaust port
5	Stud, Intake port
6	Cylinder head ass.
7	Gasket, cylinder head cover
8	Cylinder head cover
9	Bolt

UK-ST20191128

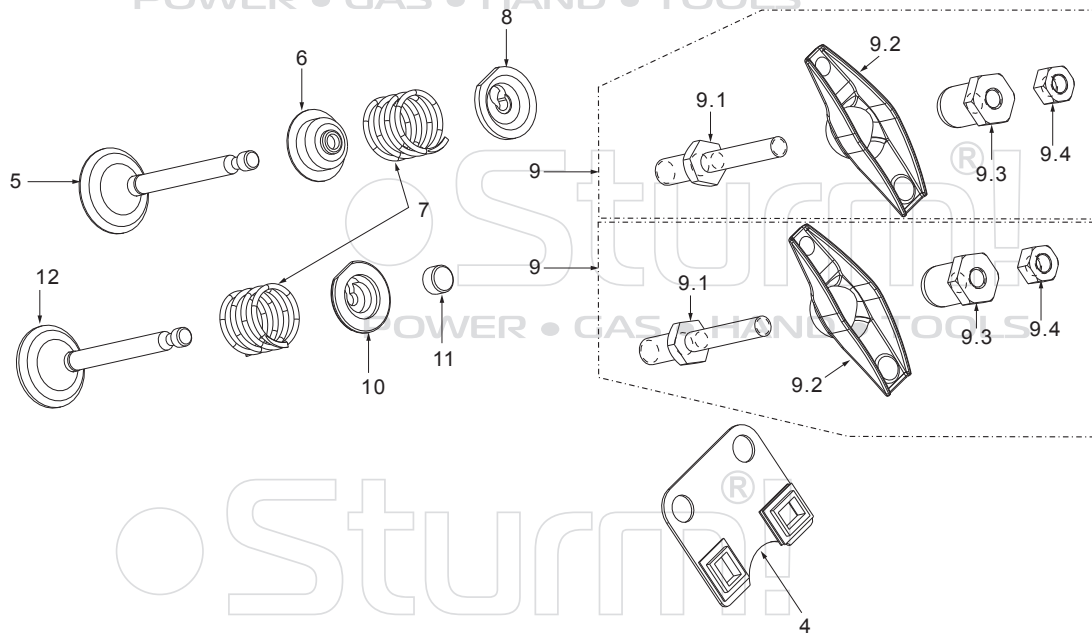

## THE ENGINE FOR PC8809DKW-6

NO.	DESCRIPTION
1	Camshaft ass.
2	Tappet
3	Pusher
4	Pusher guide
5	Intake valve
6	Oil seal, Intake valve
7	V.alve spring
8	Spring seat, Intake valve
9	Rocker ass.
9.1	Stud, Rocker ass.
9.2	Rocker
9.3	Adjust nut, sphere
9.4	Lock nut
10	Spring seat, Exhaust valve
11	Cap, Exhaust valve
12	Exhaust valve

UK-ST20191128

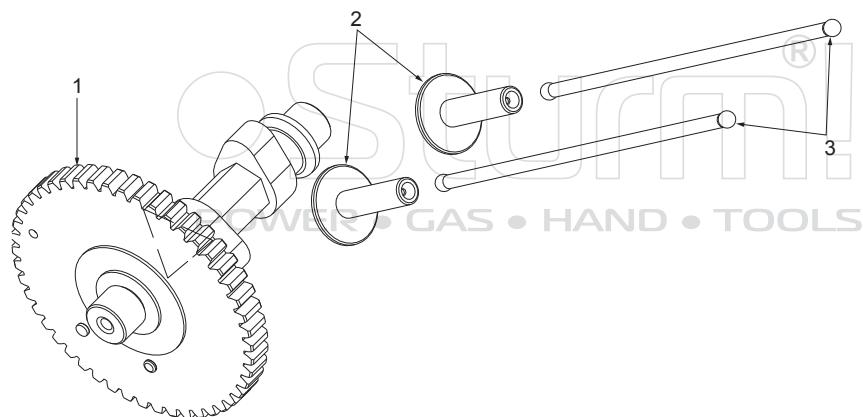

# THE ENGINE FOR PC8809DKW-7

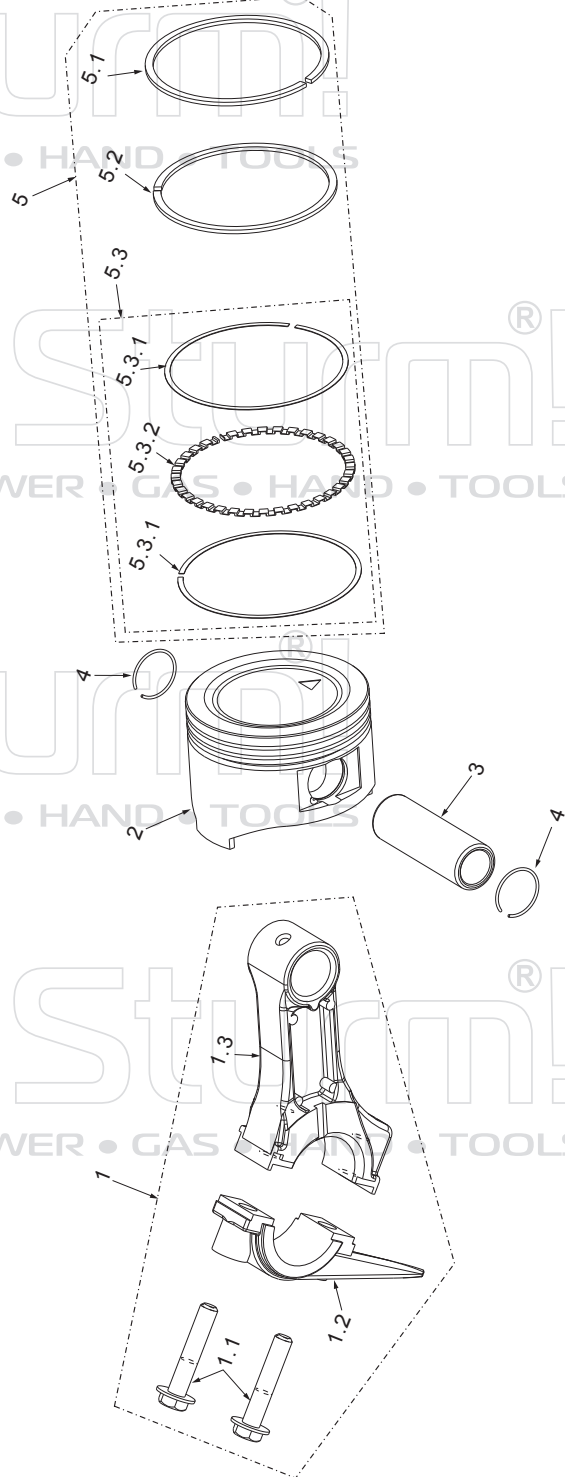

NO.	DESCRIPTION
1	Connecting rod ass.
1.1	Bolt , Connecting rod
1.2	Cover, Connecting rod
1.3	Body, Connecting rod
2	Piston
3	Piston pin
4	Cli, Piston pin
5	Piston ring ass.
5.1	First air ring
5.2	Second air ring
5.3	Oil ring ass. 1
5.3.1	Scraper ring 2
5.3.2	Set off ring

UK-ST20191128



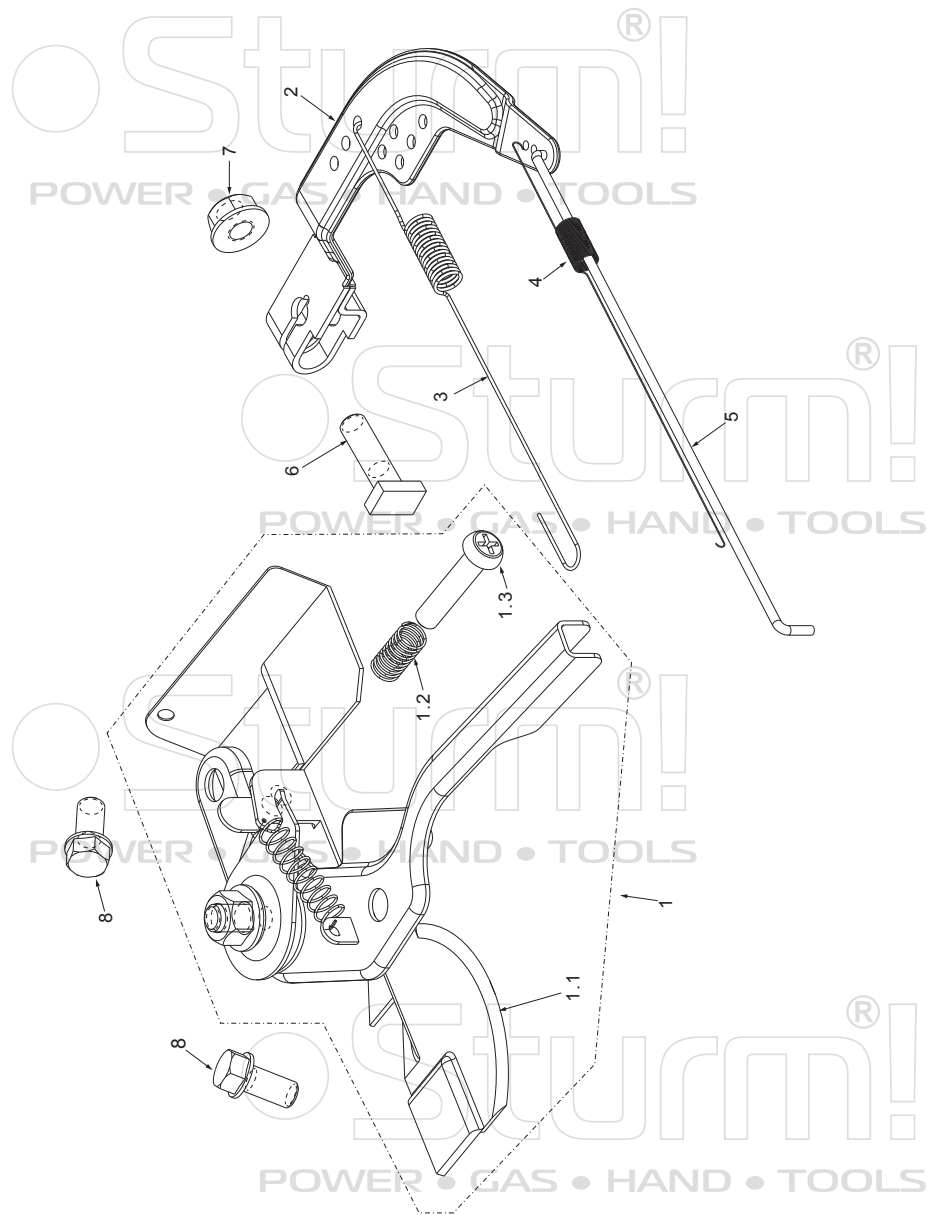

# Sturm!

POWER • GAS • HAND • TOOLS

## THE ENGINE FOR PC8809DKW-8

NO.	DESCRIPTION
1	Speed adjustment base parts
1.1	Speed adjustment base ass.
1.2	Adjustment spring
1.3	Adjustment screw
2	Speed adjustment arm
3	Return spring
4	Fine adjustment spring
5	Pulling rod
6	Quadrate bolt
7	Nut
8	Bolt

UK-ST20191128

POWER • GAS • HAND • TOOLS

Sturm!

POWER • GAS • HAND • TOOLS

# THE ENGINE FOR PC8809DKW-9

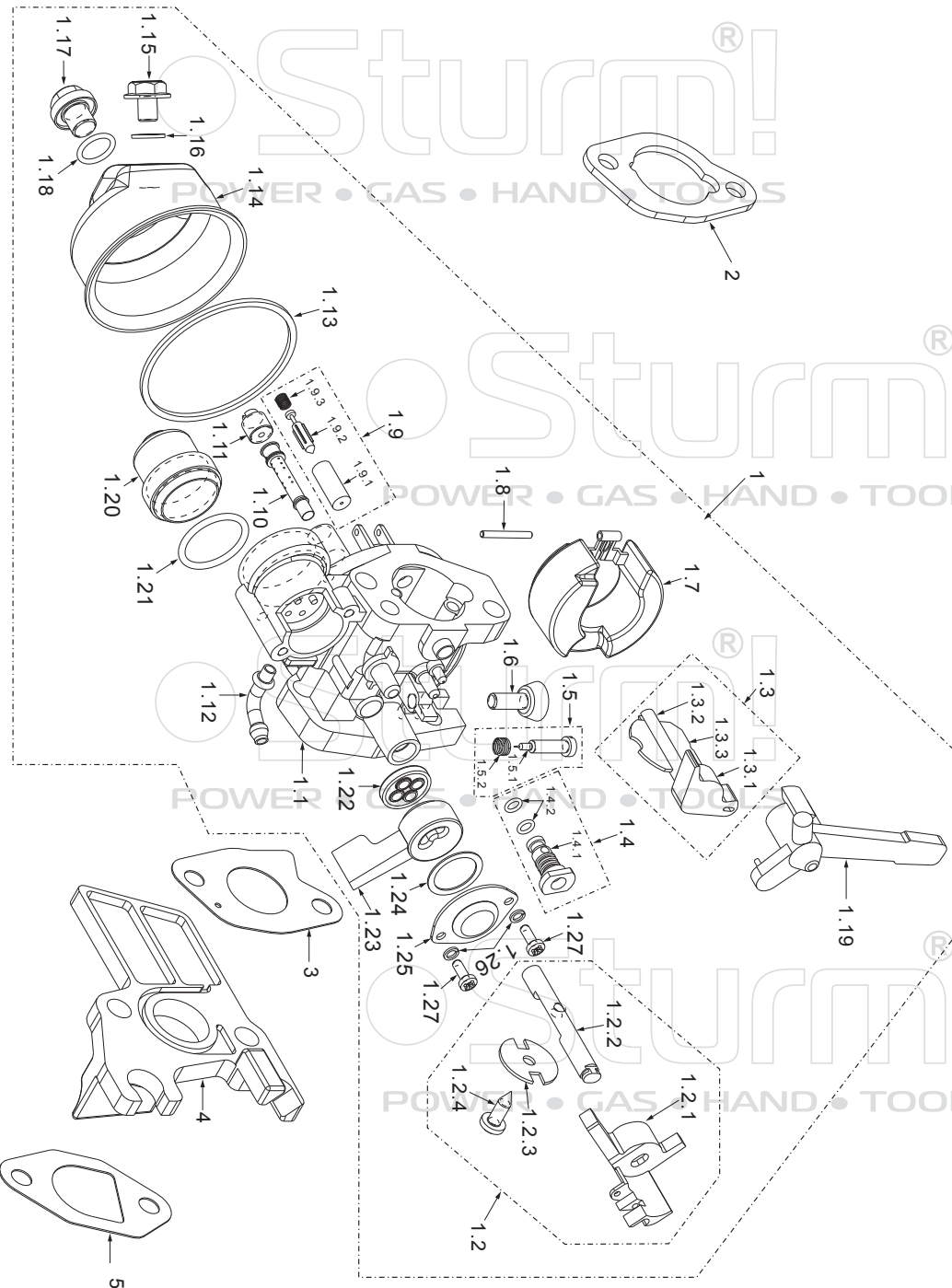

NO.	DESCRIPTION	NO.	DESCRIPTION
1	Carburetor ass.	1.9.3	Spring, Needle valve
1.1	Carburetor body	1.10	Main jet
1.2	Throttle valve ass.	1.11	Main measuring hole
1.2.1	Throttle valve cap	1.12	Fuel inlet tube
1.2.2	Throttle valve axis	1.13	Rubber seal, Fuel cup
1.2.3	Throttle valve	1.14	Fuel cup
1.2.4	Screw	1.15	Fuel drain plug
1.3	Choke valve ass.	1.16	Gasket, Fuel drain plug
1.3.1	Choke valve cap	1.17	Tighten bolt , Fuel cup
1.3.2	Choke valve axis	1.18	O - ring
1.3.3	Choke valve	1.19	Handgrip, Choke valve ass.
1.4	Measure hole ass., idle speed	1.20	Sediment cup
1.4.1	Measure hole, idel speed	1.21	O-ring
1.4.2	O-ring	1.22	Fuel valve
1.5	Adjustment screw ass., mixture ratio	1.23	Handlebar
1.5.1	Adjustment screw, mixture ratio	1.24	Spring washer
1.5.2	Spring	1.25	Upper cover
1.6	Adjustment screw, idle speed	1.26	Spring washer
1.7	Fuel floater	1.27	Screw
1.8	Pin, Fuel floater	2	Steel gasket
1.9	Needle valve ass.	3	Gasket, carburetor
1.9.1	Needle valve seat	4	Block, carburetor
1.9.2	Needle valve	5	Gasket, inlet port

UK-ST20191128



# THE ENGINE FOR PC8809DKW-10

NO.	DESCRIPTION
1	Air cleaner ass.
1.1	Air cleaner seat ass.
1.1.1	Air cleaner seat
1.1.2	Seal ring
1.1.3	Cover board
1.1.4	Screw
1.2	Filter ass.
1.2.1	Foam filter
1.2.2	Papery filter
1.2.3	Rubber fixer
1.2.4	Discal washer
1.3	Filter case
1.4	Butterfly nut
1.5	Seal ring
1.6	Air duck
2	Nut

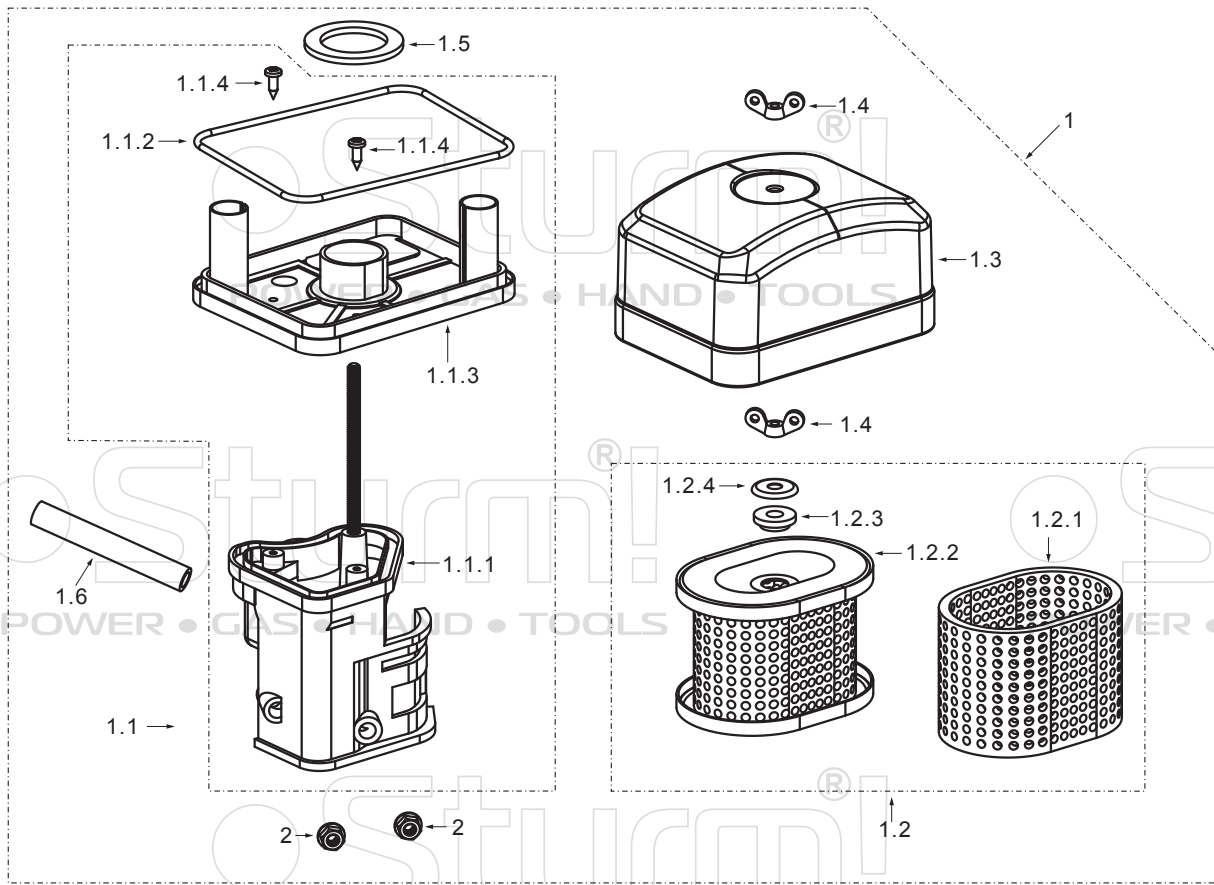

UK-ST20191128

POWER • GAS • HAND • TOOLS

POWER • GAS • HAND • TOOLS

# THE ENGINE FOR PC8809DKW-11

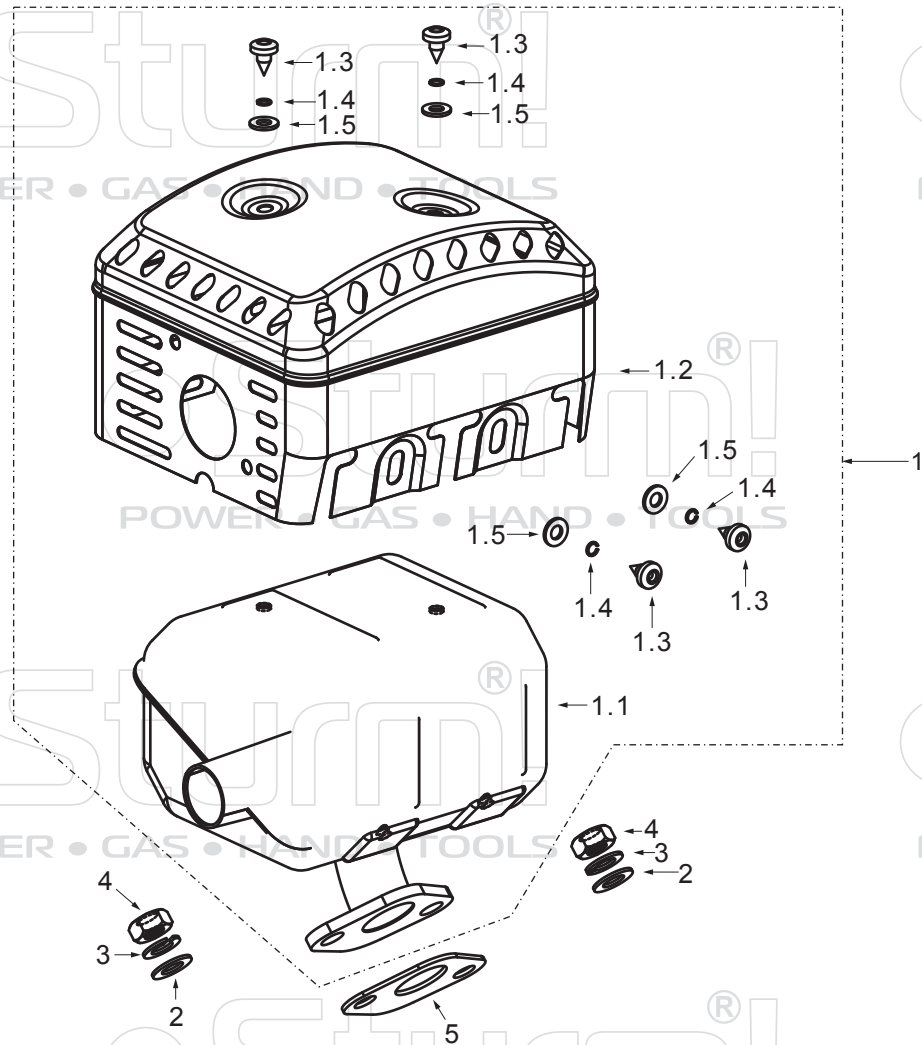

NO.	DESCRIPTION
1	Muffler ass.
1.1	Muffler body
1.2	Protector, muffler -A
1.3	Screw
1.4	Spring washer
1.5	Washer
2	Washer
3	Spring
4	Nut
5	Gasket, exhaust port

UK-ST20191128

POWER • GAS • HAND • TOOLS

POWER • GAS • HAND • TOOLS

POWER • GAS • HAND • TOOLS

POWER • GAS • HAND • TOOLS

POWER • GAS • HAND • TOOLS

POWER • GAS • HAND • TOOLS

POWER • GAS • HAND • TOOLS

POWER • GAS • HAND • TOOLS

# THE ENGINE FOR PC8809DKW-12

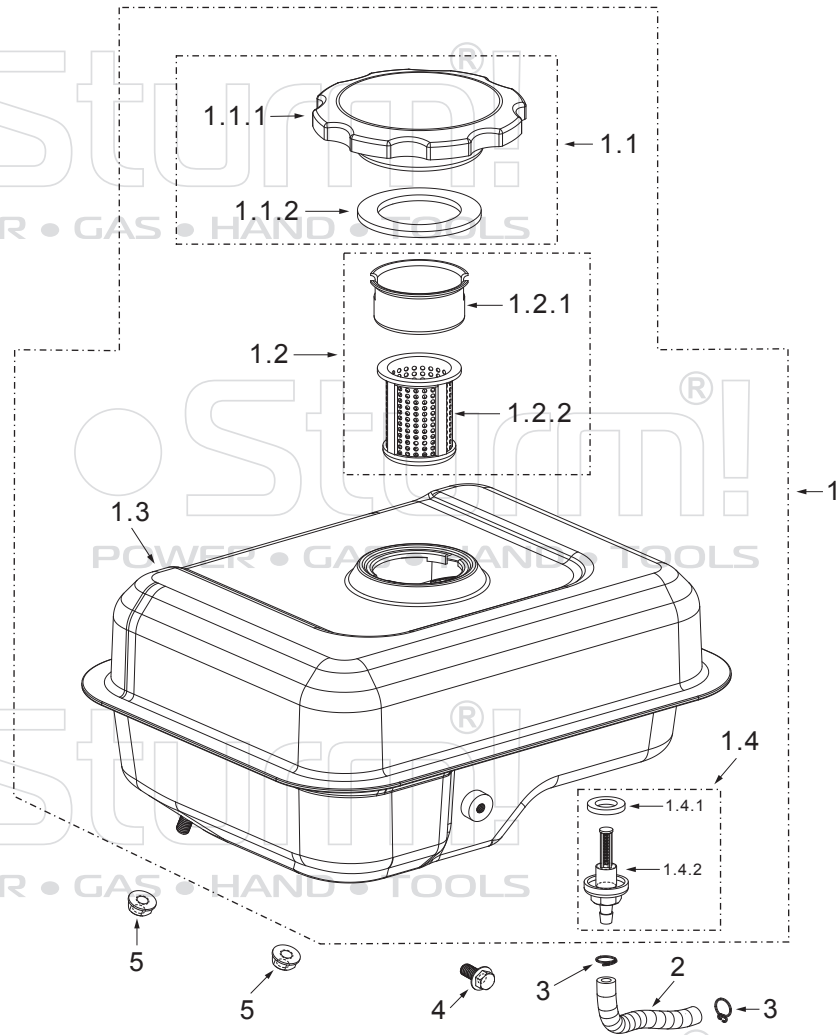

NO.	DESCRIPTION
1	Fuel tank ass.
1.1	Fuel tank cover ass.
1.1.1	Fuel tank cover
1.1.2	Rubber seal, Fuel tank cover
1.2	Fuel filter ass.
1.2.1	Support, Fuel filter
1.2.2	Fuel filter
1.3	Fuel tank
1.4	Fuel joint ass.
1.4.1	Rubber seal, Fuel joint
1.4.2	Fuel joint
2	Fuel tube
3	Clip, fuel tube
4	Bolt
5	Nut

UK-ST20191128