

PL4650SE

NO.	DESCRIPTION	NO.	DESCRIPTION
1	Inch Hex Flange Bolts 3/8-24UNF-2B X50	56	Ratchet Wheel R
2	Blade Washer	57	Rear Drive Fix Plate
3	Blade	58	Ratchet Wheel L
4	Blade Adapter Assy	59	Wheel Outer Cover
5	Bolt M8x25	60	Wheel Assy
6	Bolt M8X30	61	Wheel Inner Cover
7	Belt Cover	62	Rear Drive Assy.
8	Screw ST4.2X14	63	Height Adjustment Handle Ball
10	Split Washer φ5	64	Catcher Bottom
11	Screw ST6.3X14	65	Battery Fuse
12	Bolt M6X14	66	Locking Washer φ6
13	Nut M6	67	Rear Door Shaft
14	Deck Assy.	68	Spring
15	Side Discharge Chute	69	Rear Door
16	Side Discharge Cover	70	Throttle Control Assy
17	Side Discharge Shaft	71	Catcher Top
18	Spring	72	Catcher Screen
19	Side Discharge Bracket	73	Foam Pipe
20	Self-Locking Device Base	74	Self-Propelled Lever
21	Self-Locking Device Block	75	Upper Handle
22	Spring	76	Lever Block
23	Self-Locking Device Washer	77	Bolt M6X30
24	Spring	78	Rope Guide
25	Height Adjustment Rod	79	Nut M6
26	R Type Pin	80	Knob
27	Bolt M8X16	81	Knob Pin φ6
28	Handle Bracket Left	82	Lower Handle
29	Engine	83	Bolt M8X30
30	Water Nozzle	84	Washer φ8.5×φ16×1.5
31	Nozzle Nut	85	Knob
32	"O" Ring	86	Nut M8
33	Cable Block	87	Cable Clip
34	Nut M5	88	Brake Cable
35	Bolt M5X12	89	Self-Propelled Cable
36	Rear Door Dust Proof Board	90	Cable Fixed Plate
37	Nut M5	91	Brake Lever
38	Mulching Plug	92	Electric Start Switch
39	Height Adjustment Gear Plate	93	Bolt M5X30
40	Handle Bracket Right	94	Washer φ5.5×φ10×1
41	Screw M6X10	95	Screw ST3.5X12
42	Wheel Outer Cover	96	Cable Clip
43	Nut M8	97	Screw ST4.2X12
44	Wheel Assy	98	Handle Panel Lower Cover
45	Wheel Inner Cover	99	Electric Start Cable Assy
46	Wave Washer φ14.2×φ20.7×0.5	100	Transparent Cover
47	Front Drive Assy.	101	Handle Panel Assy
48	Belt	102	Charger
49	Self-Propelled Spring	103	Ep15 Battery Pack
50	Belt Limited Rod	104	Bolt M5X30
51	Gt Transmission	105	Quick Knob Locking Pad
52	Ratchet Pin φ5*17.8	106	Quick Knob
53	Rear Wheel Axle Sleeve	107	Quick Knob Lever
54	Ratchet Washer	108	Throttle Cable
55	Spring Washer φ12	109	Throttle Control Handle

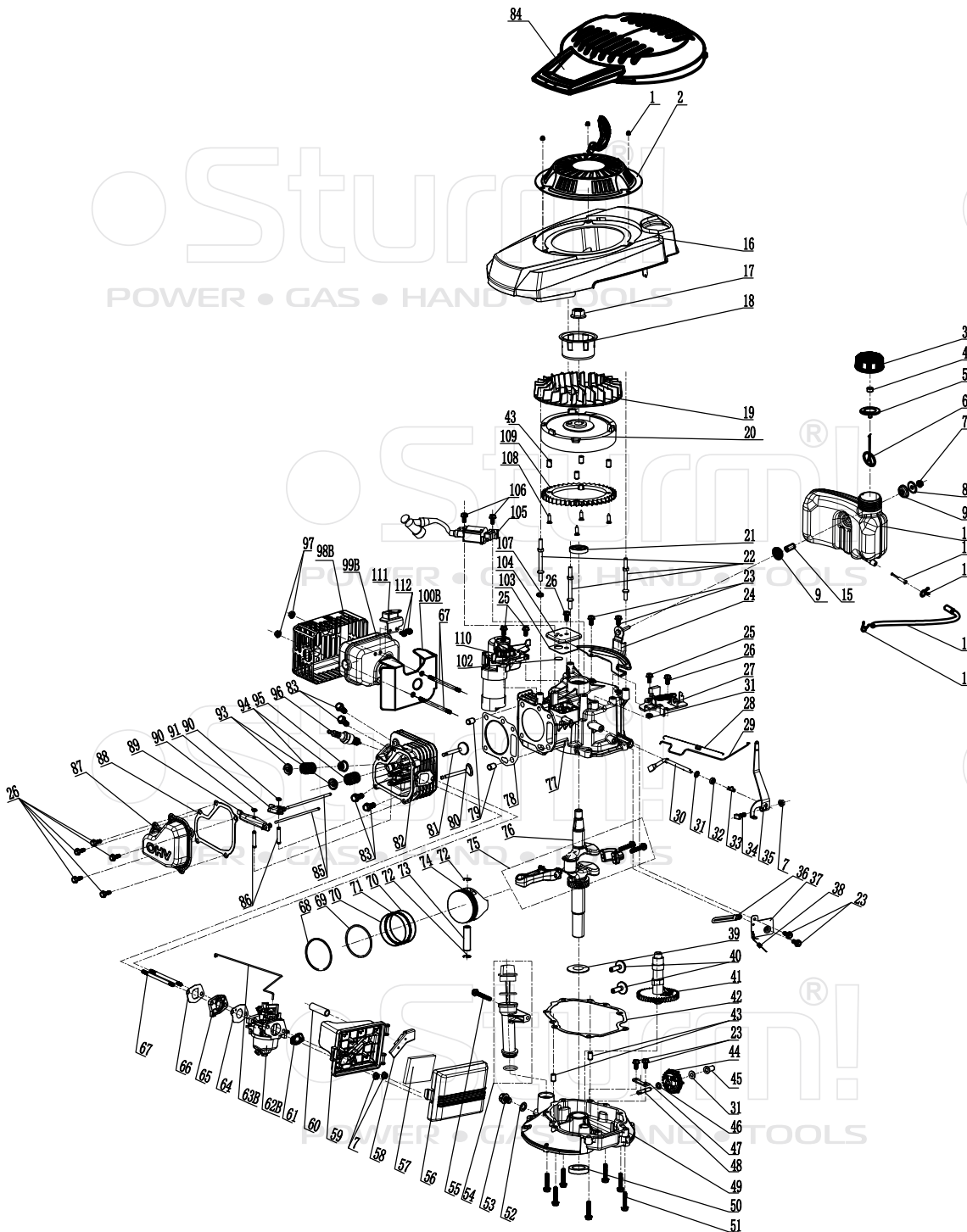

ENGINE FOR PL4650SE

NO.	DESCRIPTION	NO.	DESCRIPTION
1	Nut M6	57	Sponge Filter
2	Pull Starter Assy.	58	Vent Groove Cover Plate
3	Fuel Tank Cap	59	Air Filter Base.
4	Fuel Tank Cap Sponge	60	Exhaust Pipe
5	Fuel Tank Cap Seal Gasket	61	Air Filter Paper Pad
6	Fuel Cap Connect Cable	62B	Carburetor Assy
7	Nut M6	63B	Choke lever
8	Washer φ6.5×φ24×1.5	64	Carburetor Paper Pad II
9	Tank Vibration Cushion	65	Intake Pipe
10	Fuel Tank	66	Carburetor Paper Pad I
11	Fuel Pipe Filter Net	67	Dual-Head Bolt M6×94
12	Fuel Pipe Clip I	68	Piston Ring I
13	Fuel Pipe	69	Piston Ring II
14	Fuel Pipe Clip II	70	Guide Rail
15	Fuel Tank Installation Bushing	71	Bushing Ring
16	Fan Cover	72	Piston Pin Circlip
17	Nut M14×1.5	73	Piston Pin
18	Starter Hub	74	Piston
19	Fan	75	Connecting Rod Assy.
20	Flywheel Assy	76	Crankshaft Assy.
21	Oil Seal	77	Crankshaft Box Assy.
22	Dual-Head Bolts	78	Cylinder Head Gasket
23	Bolt M6×12	79	Cylinder Head Locating Pin
24	Fuel Tank Bracket Assy #S2	80	Exhaust Valve
25	Bolt M6×18	81	Intake Valve
26	Bolt M6×14	82	Cylinder Head Assy.
27	Detent Assy.	83	Bolt M8×45
28	Throttle Valve Spring	84	Engine Cover
29	Throttle Valve Pushrod	85	Push Rod
30	Rate-Limiting Rocker Arm Shaft	86	Valve Rocker Arm Pin Shaft
31	Washer φ6.2×φ15×0.5	87	Cylinder Head Cover
32	Oil Seal	88	Cylinder Head Gasket
33	R Type Pin	89	Exhaust Valve Rocker Arm Assembly
34	T-Bolt	90	Split Washer φ5
35	Throttle Rocker Arm	91	Inlet Valve Rocker Arm Assembly
36	Clip	93	Inlet Valve Spring Disc
37	Governor Assembly	94	Valve Spring
38	Throttle Control Spring	95	Valve Oil Seal Group
39	Clockwise Gear Washer	96	Spark Plug
40	Pin	97	Nut M6
41	Camshaft Assy	98B	Muffler Cover Assy.
42	Crankcase Gasket	99B	Muffler Assy.
43	Pin φ8×14	100B	Muffler Insulation Cushion
44	Rate-Limiting Gear Assy.	101	Wind Deflector 1
45	Sliding Sleeve	102	Respirator Valve Plate
46	Washer φ6.5×φ12×1	103	Respirator Head Gasket
47	Rate-Limiting Gear Shaft Clamp	104	Respirator Cover Plate Assembly
48	Rate-Limiting Gear Shaft	105	Ignition Assy.
49	Crankcase Cover	106	Bolt M6×25
50	Oil Seal	107	Washer φ6.5×φ16×3
51	Bolt M6×30	108	Screw M5X25
52	Oil Drain Bolt Gasket	109	flywheel ring gear
53	Oil drain bolt M10×P1.25×15	110	STARTER MOTOR
54	Lubricating Gauge Assy	111	Choke controller 1#
55	Bolt M6×50	112	Bolt M5X10
56	Air Filter Cover		