

PSM932000RV

NO.	DESCRIPTION
1	LED DISPLAY PANEL
3	PCB
4	FRONT AND SIDES METAL CASE
6	EU STANDARD SOCKET
8	TOROIDAL TRANSFORMER
9	BASE COVER
10	SWITCH
13	RELAY
14	CURRENT TRANSFORMER
15	HEXAGON NUT
16	SPRING PAD
17	FLAT PAD
18	IRON COVER OF TRANSFORMER
19	SMALL RUBBER PAD
20	CLAMP
21	POWER CABLE AND PLUG
22	TEMPERATURE CONTROLLER
23	SCREW ROD
24	BIG RUBBER PAD

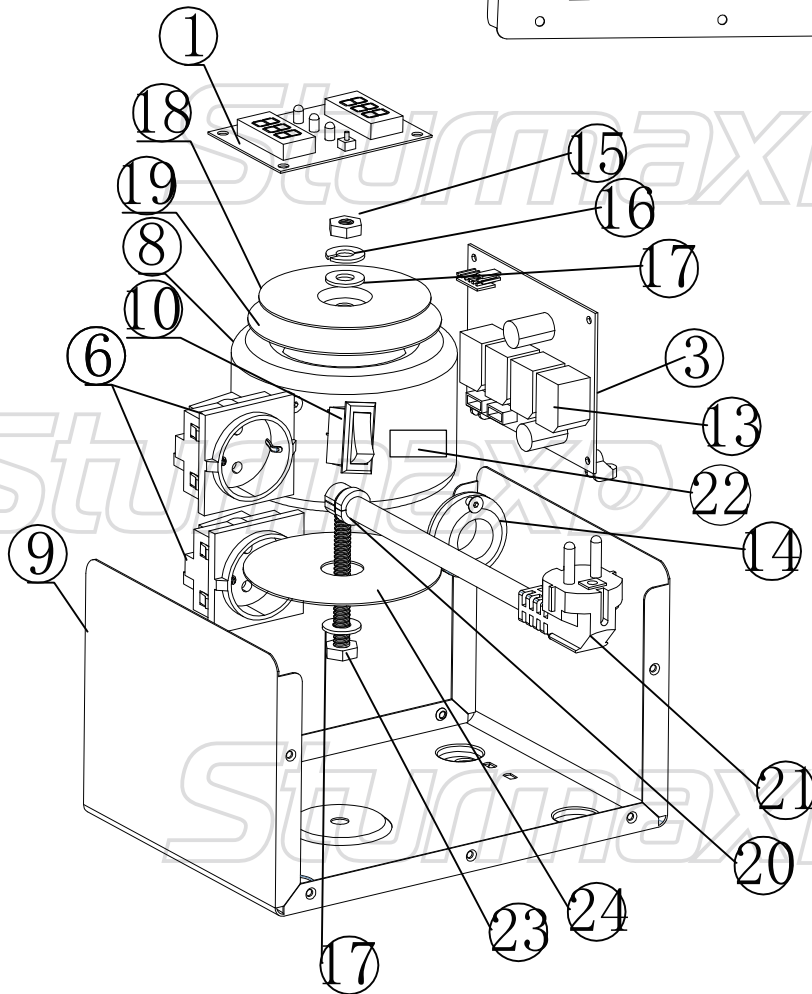

PSM932000RV-EX-UKW230711