

RH2532V

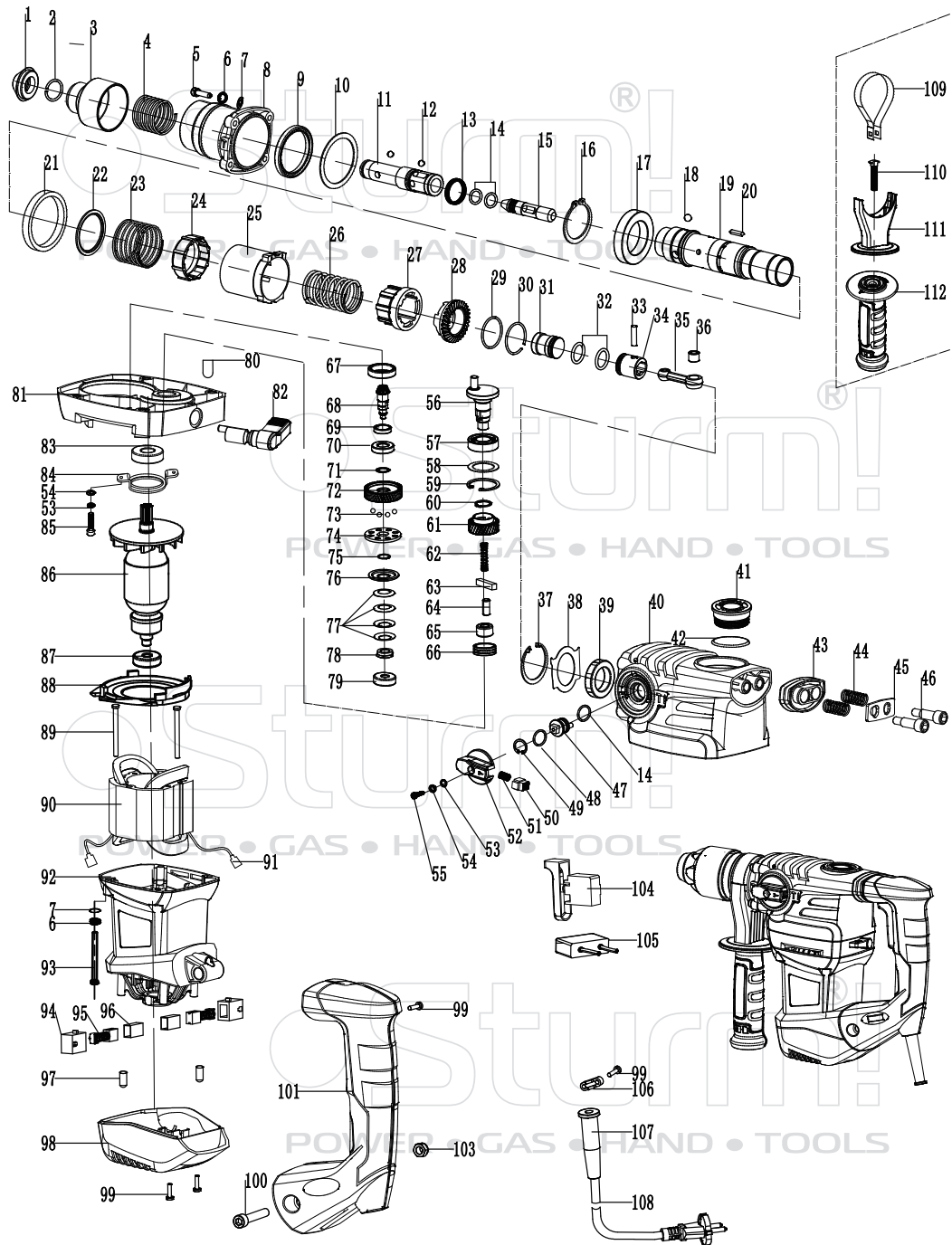

NO.	DESCRIPTION	NO.	DESCRIPTION
1	RUBBER HEAD	57	BEARING 6003RS
2	STEEL RING 17.5*2	58	WASHER 34.5X28.5X1
3	STEEL FRAME	59	WASHER 35
4	SPRING 30.2*1.8*76	60	WASHER 17
5	SCREW/M5X25	61	GEAR
6	WASHER	62	SPRING 6.8*1.2*33
7	WASHER	63	FLAT KEY 5*5*22
8	CYLINDER HOUSE	64	PIN
9	OIL SEAL 35*51*6	65	BUSH
10	WASHER 45*54.5*1	66	STEEL SLEEVE 22*26*9
11	TELEFLEX	67	OIL SEAL 19*28*4.5
12	BALL Ø7.14	68	SMALL GEAR
13	X-RING 20.9*2.2*4	69	WASHER
14	O-RING 11*2	70	BEARING6002
15	IMPACT HAMMER	71	WASHER 14.1*19*0.5
16	WASHER35	72	GEAR 39 TEETH
17	BEARING 61907-RZ	73	BALL 5
18	BALL Ø7.94	74	FIXED PLATE
19	CYLINDER	75	STEEL RING
20	FLAT KEY 3X3X18	76	ACTIVE PLATE
21	PLASTIC RING 47X55X7	77	DISC SPRING
22	WASHER 38X47X1.5	78	NUT M10*0.75
23	SPRING 42*2*28	79	BEARING 627
24	PLASTIC SLEEVE	80	BUTTON PIN
25	CHISEL LOCK DISTANCE SLEEVE	81	MIDDLE COVER
26	SPRING34*2.5*50	82	TWISTING FOR HAMMER
27	CLUTCH	83	BEARING 6001RS
28	GAMP GEAR	84	BEARING BOARD
29	O-RING 28*1.8	85	SCREW/M4X14
30	STEEL RING 28*1.6	86	ROTOR
31	RAMMER 25*30	87	BEARING608
32	O-RING 19*3.1	88	FAN GUIDE
33	PISTON PIN 6*23.5	89	SCREW
34	PISTON 25*27	90	STATOR
35	CONNECTING ROD	91	ILLUSTRATED PIECE
36	STEEL SLEEVE	92	MOTOR HOUSING
37	WASHER 47	93	SCREW/M5*50
38	OIL BAFFLE PLATE	94	BRUSH CASE
39	BEARING 30X47X9	95	CARBON BRUSH
40	GEAR BOX	96	BRUSH HOLDER
41	OIL COVER	97	RUBBER PIN
42	O-RING 31.5X2	98	BACK COVER
43	ANTI-VIBRATION HOLDER	99	SELF-TAPPING SCREW ST3.9*16
44	ANTI-VIBRATION SPRING	100	SCREW/M8X45
45	ANTI-VIBRATION BOARD	101	HANDLE
46	ANTI-VIBRATION SCREW	103	NUT M8
47	DIAL TWIST	104	SWITCH
48	WASHER	105	ELECTRIC CAPACITY
49	WASHER 18	106	CABLE BOARD
50	BUTTON	107	CABLE SHEATH
51	KNOB SPRING	108	CABLE
52	BUTTON	109	HOOP
53	WASHER 4	110	T-SHAPE SCREW M8*50
54	SPRING WASHER 4	111	BRACKET
55	CROSS RECESS HEAD SCREW M4X14	112	AUXILIARY HANDLE
56	ECCENTRIC SHAFT		