

# VC7220Q

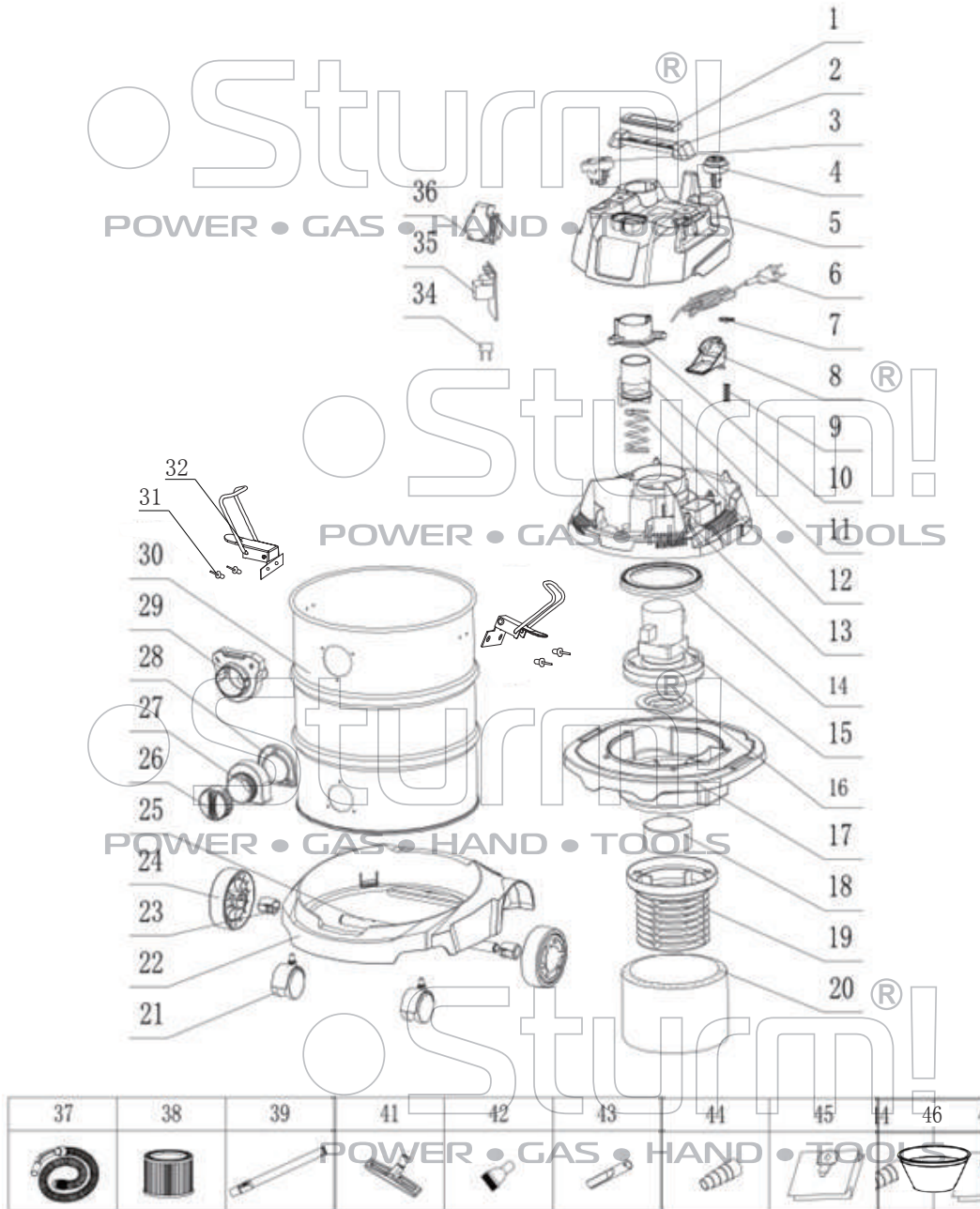

NO.	DESCRIPTION	NO.	DESCRIPTION
1	HANDLE COVER	24	BIG WHEEL
2	FIXED HANDLE	25	AXLE FOR BIG WHEEL
3	WATERPROOF SWITCH	26	DRAINAGE SCREW
4	DUST SHAKING SWITCH	27	DRAINAGE
5	DUST SHAKING BUTTON	28	DRAINAGE BASE
6	POWER CABLE	29	CONNECTION HEAD
7	CABLE BLOCK	30	S/S TANK
8	DUST SHAKING BOARD	31	RIVET
9	DUST SHAKING SPRING	32	LOCK
10	BLOWER COVER	34	CAPACITOR
11	BLOWER CONTROLLER	35	PCB BOARD
12	BLOWER SPRING	36	SYNCHRONIZATION POWER SOCKET
13	MID COVER	37	PLASTIC HOSE
14	MOTOR SEAL RING	38	HEPA FILTER
15	MOTOR	39	METAL TELESCOPIC TUBE
16	MOTOR BLOCK	41	FLOOR BRUSH
17	BARREL CAP	42	ROUND BRUSH
18	SAFETY VALVE	43	CREVICE NOZZLE
19	BRACKET	44	ADAPTER
20	SPONGE FILTER	45	PAPER FILTER BAG
21	SMALL WHEEL	46	CLOTH FILTER
22	BASE		
23	WHEEL BLOCK		

UK-ST20190912