

WP9709VS

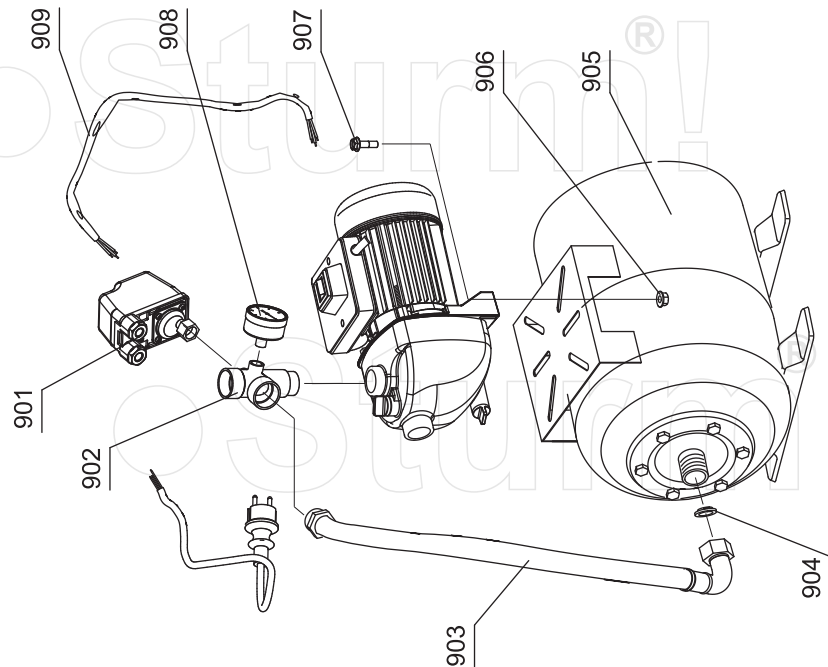
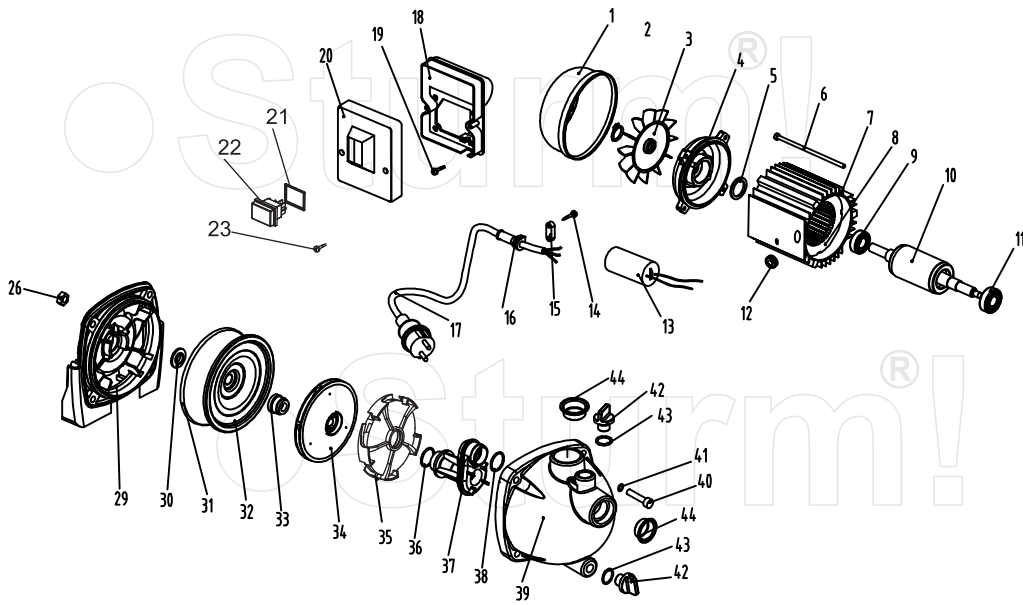

NO.	DESCRIPTION	NO.	DESCRIPTION
1	FAN COVER	30	SWING RING
2	CIRCLIP	31	"O" RING
3	FAN	32	SEALING RING
4	REAR COVER	33	MECHANISM AIRPROOF
5	WAVEFORM SPRING	34	IMPELLER
6	BOLT	35	GUIDE FLOWING PLATE
7	ALUMINIUM HOUSING	36	"O" RING
8	STATOR	37	GUIDE FLOWING PIECE
9	BEARING 6201-2Z	38	"O" RING
10	ROTOR	39	PUMP HEAD
11	BEARING 6202-2Z	40	BOLT
12	CORD SLEEVE	41	WASHER
13	CAPACITOR	42	VALUE COVER
14	TAPPING SCREW	43	"O" RING
15	CORD CLAMP	44	DUSTPROOF COVER
16	CORD SLEEVE		
17	CORD	901	MECHANISM PRESSURE SWITCH
18	JUNCTION BOX	902	FIVE DIRECTION CONNECTOR
19	TAPPING SCREW	903	SOFT TUBE
20	JUNCTION BOX COVER	904	SEALING WASHER
21	SEALING WASHER	905	PRESSURE POT
22	WATERPROOF SWITCH	906	BOLT
23	TAPPING SCREW	907	NUT
26	NUT	908	PRESSURE METER
29	FORE COVER	909	CORD

RU090803-3